



**PROPELLER
SHAFTS
ALBERI
TRASMISSIONE**



CATALOGUE 2026
FOR PASSENGER CARS AND
COMMERCIAL VEHICLES

CATALOGUE 2026
PER AUTOVETTURE E
VEICOLI COMMERCIALI





Japanparts®

Azienda

Nata oltre 35 anni fa per distribuire una gamma completa e di qualità di ricambi per veicoli asiatici, Japanparts srl si distingue oggi per un'offerta sempre più articolata a copertura di applicazioni europee e americane.

JAPANPARTS s.r.l.



Japanparts S.r.l. opera dal 1988 come azienda leader nel settore dell'importazione e distribuzione di ricambi per veicoli asiatici, americani ed europei.

L'azienda offre gamme ampie, profonde e dagli elevati standard qualitativi. Una logistica efficiente che poche aziende possono vantare ed una distribuzione capillare in Italia e all'estero.

Gamme ampie, profonde e di qualità

9 famiglie, 158 linee e circa 69.000 codici prodotto compongono **la gamma completa di ricambi** offerti da Japanparts S.r.l. per coprire le esigenze meccaniche, elettriche e di rettifica di vetture europee, asiatiche e americane. L'offerta si distingue per ampiezza, profondità e per l'accurata selezione dei fornitori, scelti sempre in base agli elevati standard qualitativi.

Player a tutto tondo

L'offerta di Japanparts S.r.l. viene costantemente aggiornata per tener conto delle nuove esigenze del settore **della riparazione auto**, sia in termini di nuovi prodotti sia codici. Japanparts S.r.l. si presenta oggi come un'azienda sempre più importante dell'aftermarket, capace di competere, per qualità e offerta, con le migliori realtà internazionali.

Una logistica invidiabile

Ogni prodotto distribuito da Japanparts S.r.l. beneficia di un servizio al cliente tempestivo: **24 ore** per la penisola, **48 ore** per le isole e massimo **5 giorni** per l'estero.

Tutto ciò è reso possibile da un **magazzino** con una superficie di stoccaggio di oltre 70.000 mq. che garantisce in ogni momento la disponibilità dei ricambi.

Una distribuzione capillare

I prodotti di Japanparts S.r.l. sono disponibili in Italia grazie ad accordi con oltre **50 partner distributivi**. Japanparts S.r.l. ha una forte penetrazione commerciale anche all'estero, con più di **400 aziende partner** nelle principali aree geografiche a livello globale.

La nostra azienda è stata certificata ISO 9001:2015 per la sua evoluta logistica, a testimonianza dell'elevata efficienza raggiunta. Tutti i nostri processi seguono rigidi protocolli che assicurano un servizio eccellente e tempestivo a tutta la nostra clientela.

PROPELLER SHAFT ALBERO DI TRASMISSIONE

The propeller shaft is an essential mechanical component for transferring torque and motion from the engine to the driven wheels, especially in vehicles with front engines and rear-wheel or all-wheel drive.

It consists of a **cylindrical shaft**, typically made of steel or lightweight materials, with **cardan or elastic joints at the ends**. These joints compensate for relative movements between vehicle parts, such as suspension oscillations, ensuring a smooth transfer of power.

L'albero di trasmissione è un componente meccanico essenziale per **trasferire la coppia e il moto dal motore alle ruote motrici**, specialmente nei veicoli con motore anteriore e trazione posteriore o integrale.

Si compone di **un'asta cilindrica**, solitamente in acciaio o materiali leggeri, con **giunti cardanici o elastici alle estremità**. Questi giunti compensano i movimenti relativi tra le parti del veicolo, come le oscillazioni delle sospensioni, garantendo un trasferimento uniforme della forza.

CHARACTERISTICS AND USAGE CARATTERISTICHE E UTILIZZO

The main characteristics of the propeller shaft are:

- **Rigidity:** Strong enough to withstand the transmitted torque.
- **Elasticity:** Tolerant to deformation to prevent vibrations.
- **Durability:** Resistant to torsion, bending, and wear.

The propeller shaft is essential in vehicles with front engines and rear-wheel drive, as well as in **all-wheel-drive (4x4) vehicles**.

Replacement may be necessary for several reasons, including wear of the cardan joints, physical damage from impacts or accidents, vibrations, corrosion, or bearing failures.

Le caratteristiche principali dell'albero di trasmissione sono:

- **Rigidità:** resistente per sopportare la coppia trasmessa.
- **Elasticità:** tollerante a deformazioni per evitare vibrazioni.
- **Resistenza:** resistente a torsione, flessione e usura.

L'albero di trasmissione è fondamentale nei veicoli a trazione posteriore con motore anteriore e nei veicoli a trazione integrale (4x4).

La sostituzione può essere necessaria per diverse cause, tra cui **usura dei giunti cardanici**, danni fisici dovuti a urti o incidenti, **vibrazioni**, **corrosione** o guasti nei cuscinetti.

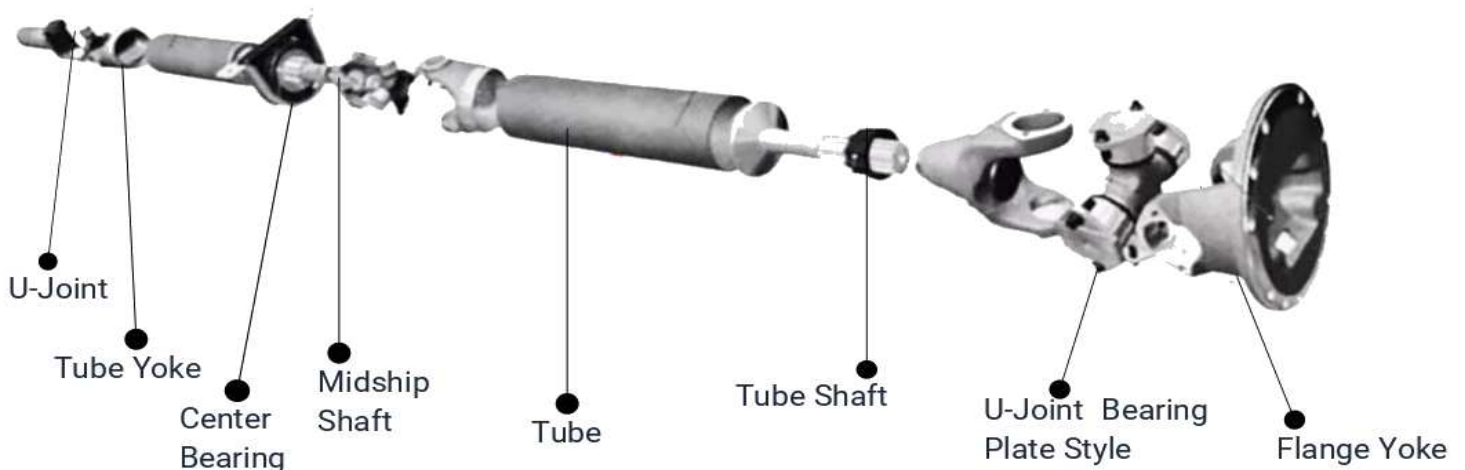

APPLICAZIONE (APPLICATION)	ANNO (YEAR)	CODICE (CODE)	O.E. (OR. NUMB.)	DIAMETRO (DIAMETER)				LUNGH. (LENGH.)
				EST. 1 (EXT. 1)	EST. 2 (EXT. 2)	FORO 1 (HOLE 1)	FORO 2 (HOLE 2)	
A4 (B8)	07 > 15	AC-0088	8K0521101G 8K0521101N 8K0521101AA	99,7		86		1478
A5 SPORTBACK (8TA)	07 > 16	AC-0088	8K0521101G 8K0521101N 8K0521101AA	99,7		86		1478
A6 (C6)	04 > 12	AC-0082	4F0521101F 4F0521101B	99,7	99,7	86	86	1763
A8 (4H) (FORI : 6) - (ALESAGGIO: 8 mm.)	09 > 17	AC-0089	4H4521101B 4H4521101D 4H4521101F	100				1801
Q3 (8U)	11 > 18	AC-0024	5N0521101C 5N0521101E 5N0521101M	16	16	96	105	2138
Q5 (8RB)	08 > 12	AC-0022	8R0521101F 8R0521101L 8R0521101M	99,7		86		1494
Q5 (8RB)	08 > 12	AC-0023	8R0521101E 8R0521101K 8R0521101P	99,7		86		1476
Q5 (8RB)	08 > 12	AC-0103	8R0521101B	99,7		86		1493
Q7 (4L) (LATO ANTERIORE)	06 > 15	AC-0104	7L0521101H 7L6521101M 7L6521101Q	99,47	99,47	86	86	632
Q7 (4L) (MOT. 3,0 TFSI QUATTRO)	06 > 15	AC-0032	7L8521102S 7L8521105G 7L8521105L	32,12	30,12			1562
Q7 (4L) (MOT. 3,6 FSI QUATTRO)	06 > 10	AC-0128	7L8521102D 7L8521102F 7L8521102M	99,5	99,5	86	86	1438
Q7 (4M) (MOT. 3,0 TFSI QUATTRO)	15 >	AC-0032	7L8521102S 7L8521105G 7L8521105L	32,12	30,12			1562

N.B.: I CODICI O.E. ED IL LORO TESTO SONO RIPORTATI SOLO A TITOLO INDICATIVO
THE O.E. CODES AND THEIR TEXT ARE REPORTED ONLY FOR INDICATIVE PURPOSE

APPLICAZIONE (APPLICATION)	ANNO (YEAR)	CODICE (CODE)	O.E. (OR. NUMB.)	DIAMETRO (DIAMETER)				LUNGH. (LENGH.)
				EST. 1 (EXT. 1)	EST. 2 (EXT. 2)	FORO 1 (HOLE 1)	FORO 2 (HOLE 2)	
SERIE 1 (E87)	04 > 07	AC-0114	26117550770					1443
SERIE 2 (F22 - F87) (LATO ANTERIORE)	15 > 21	AC-0115	26207529294	47	47	77	77	738
SERIE 3 (E46)	98 > 05	AC-0090	26111229557 26117523925	14	47	77,8	84	1554
SERIE 3 (E46) (LATO ANTERIORE)	98 > 05	AC-0141	26207526677 26207502968 26207525969	47	47	84	84	718
SERIE 3 (E90 - E91 - E92 - E93) (LATO ANTERIORE)	05 > 11	AC-0115	26207529294	47	47	77	77	738
SERIE 3 (E90 - E91 - E92 - E93)	05 > 11	AC-0138	26107551199 26107527355	14	47	96	84	1423
SERIE 3 (F30 - F31 - F35 - F80) (LATO ANTERIORE)	12 > 19	AC-0146	26207632650 26208626955 26209425910	47	47	77	77	715
SERIE 4 (F32 - F33 - F36 - F82) (LATO ANTERIORE)	13 > 20	AC-0146	26207632650 26208626955 26209425910	47	47	77	77	715
SERIE 5 (E60 - E61) (LATO ANTERIORE)	05 > 09	AC-0116	26207534636	47	47	77	77	644
SERIE 5 (F07)	09 > 16	AC-0044	26107562814 26107591610 26107614658	14	16	105	105	1622
SERIE 5 (F07 - F10 - F11 - F18) (LATO ANTERIORE)	09 > 16	AC-0137	26207593164 26207620521 26207629988 26208628043	47	47	77	77	730
SERIE 6 (F06 - F12 - F13) (LATO ANTERIORE)	11 > 18	AC-0137	26207593164 26207620521 26207629988 26208628043	47	47	77	77	730
SERIE 7 (F01 - F02 - F03 - F04)	08 > 15	AC-0044	26107562814 26107591610 26107614658	14	16	105	105	1622

N.B.: I CODICI O.E. ED IL LORO TESTO SONO RIPORTATI SOLO A TITOLO INDICATIVO
THE O.E. CODES AND THEIR TEXT ARE REPORTED ONLY FOR INDICATIVE PURPOSE

APPLICAZIONE (APPLICATION)	ANNO (YEAR)	CODICE (CODE)	O.E. (OR. NUMB.)	DIAMETRO (DIAMETER)				LUNGH. (LENGH.)
				EST. 1 (EXT. 1)	EST. 2 (EXT. 2)	FORO 1 (HOLE 1)	FORO 2 (HOLE 2)	
SERIE 7 (F01 - F02 - F03 - F04) (LATO ANTERIORE)	08 > 15	AC-0137	26207593164 26207620521 26207629988 26208628043	47	47	77	77	730
X1 (E84)	09 > 15	AC-0115	26207529294	47	47	77	77	738
X3 (E83) (LATO ANTERIORE)	04 > 10	AC-0117	26203401609	47	47	84	84	702
X3 (E83) (LATO ANTERIORE)	04 > 10	AC-0141	26207526677 26207502968 26207525969	47	47	84	84	718
X3 (E83) (LATO ANTERIORE)	04 > 10	AC-0151	26203423931					686
X3 (E83) (LATO POSTERIORE)	04 > 10	AC-0077	26103402134	47	14	84	96	1253
X3 (E83) (LATO POSTERIORE)	04 > 10	AC-0093	26103402136	47	14	84	96	1269
X3 (F25)	10 > 17	AC-0135	26207589985 26208605867 26209425909	47			77	733
X4 (F26)	14 > 18	AC-0135	26207589985 26208605867 26209425909	47			77	733
X5 (E53) (LATO ANTERIORE)	00 > 06	AC-0118	26207508629	10		78		774
X5 (E53) (LATO POSTERIORE)	00 > 06	AC-0092	26107524364 26107549298	99,5	14	86	96	1338
X5 (E70) (LATO ANTERIORE)	09 > 13	AC-0147	26207556020		47		84	705
X5 (F15 - F85) (T.T TRANNE xDRIVE 2,8)	13 > 18	AC-0014	26207597649 26208605866 26209425907	27	47		77	709

N.B.: I CODICI O.E. ED IL LORO TESTO SONO RIPORTATI SOLO A TITOLO INDICATIVO
THE O.E. CODES AND THEIR TEXT ARE REPORTED ONLY FOR INDICATIVE PURPOSE

APPLICAZIONE (APPLICATION)	ANNO (YEAR)	CODICE (CODE)	O.E. (OR. NUMB.)	DIAMETRO (DIAMETER)				LUNGH. (LENGH.)
				EST. 1 (EXT. 1)	EST. 2 (EXT. 2)	FORO 1 (HOLE 1)	FORO 2 (HOLE 2)	
CAMARO	10 > 15	AC-0125	92194140	16	16	110	110	1315
CAPTIVA	06 >	AC-0025	0446073 20781756 96624771	99,7	45	86	91	1932
EQUINOX	03 >	AC-0139	25918054 25793000 20811303 19355361	99,7	48,5	86	91	2158
PONTIAC TORRENT	04 >	AC-0139	25918054 25793000 20811303 19355361	99,7	48,5	86	91	2158

N.B.: I CODICI O.E. ED IL LORO TESTO SONO RIPORTATI SOLO A TITOLO INDICATIVO
THE O.E. CODES AND THEIR TEXT ARE REPORTED ONLY FOR INDICATIVE PURPOSE

APPLICAZIONE (APPLICATION)	ANNO (YEAR)	CODICE (CODE)	O.E. (OR. NUMB.)	DIAMETRO (DIAMETER)				LUNGH. (LENGH.)
				EST. 1 (EXT. 1)	EST. 2 (EXT. 2)	FORO 1 (HOLE 1)	FORO 2 (HOLE 2)	
300 C (LX) (3,6 - 5,7) - (LATO ANTERIORE)	05 > 14	AC-0099	68200149AA 68200149AB 68200149AC	57	76			651
CALIBER	07 > 08	AC-0121	05273310AA 05273310AB					2020
CHALLENGER COUPE' (3,6 - 5,7) - (LATO ANTERIORE)	09/10 >	AC-0099	68200149AA 68200149AB 68200149AC	57	76			651
CHARGER (3,6 - 5,7) - (LATO ANTERIORE)	09/10 >	AC-0099	68200149AA 68200149AB 68200149AC	57	76			651
JOURNEY	08 >	AC-0081	5157005AD 5157005AE 5157005AF	16	86	80	74	2183
RAM 2500	03 > 13	AC-0127	52105934AA	79,4		108	73,8	809

N.B.: I CODICI O.E. ED IL LORO TESTO SONO RIPORTATI SOLO A TITOLO INDICATIVO
THE O.E. CODES AND THEIR TEXT ARE REPORTED ONLY FOR INDICATIVE PURPOSE

APPLICAZIONE (APPLICATION)	ANNO (YEAR)	CODICE (CODE)	O.E. (OR. NUMB.)	DIAMETRO (DIAMETER)				LUNGH. (LENGH.)
				EST. 1 (EXT. 1)	EST. 2 (EXT. 2)	FORO 1 (HOLE 1)	FORO 2 (HOLE 2)	
500 X	14 >	AC-0045	55267432 55263435 55275848	86,7				2191 2195
PANDA (141)	83 > 03	AC-0129	46307205 5996641 5996642 7541751					1041,5
PANDA (169) (FORI: 6) - (ALESAGGIO: 8,2 mm.) (CON CROCIERA INTERCAMB.)	03 > 12	AC-0001	46349688 55264146	83,7			74	1729 1780
PANDA (312 - 319) (FORI: 6) - (ALESAGGIO: 8,2 mm.) (CON CROCIERA INTERCAMB.)	12 >	AC-0001	46349688 55264146	83,7			74	1729 1780
FULLBACK (KT) (LATO ANTERIORE)	15 > 18	AC-0161	3401B041	65	45	95	79,4	764

N.B.: I CODICI O.E. ED IL LORO TESTO SONO RIPORTATI SOLO A TITOLO INDICATIVO
THE O.E. CODES AND THEIR TEXT ARE REPORTED ONLY FOR INDICATIVE PURPOSE

APPLICAZIONE (APPLICATION)	ANNO (YEAR)	CODICE (CODE)	O.E. (OR. NUMB.)	DIAMETRO (DIAMETER)				LUNGH. (LENGH.)
				EST. 1 (EXT. 1)	EST. 2 (EXT. 2)	FORO 1 (HOLE 1)	FORO 2 (HOLE 2)	
EDGE (U387)	06 >	AC-0140	7T4Z-4R602A DT4Z4R602A	60,3	79	84,9	104,7	2035
EXPEDITION (5,4 4X4) - (LATO ANTERIORE)	07 >	AC-0123	7L1Z4A376A 7L1Z4A376B	110	114	91	98	816
F150 (6,2 4X4) - (LATO ANTERIORE)	07 > 14	AC-0123	7L1Z4A376A 7L1Z4A376B	110	114	91	98	816
F150 (LATO POSTERIORE)	11 > 14	AC-0124	BL3Z4R602H			146		2329
FUSION (3 VOLUMI)	09 > 12	AC-0142	AE5Z4R602A 8E5Z4R602A 7E5Z4R602B 7E5Z4R602A	60,3	79	84,9	104,7	2015
KUGA II	12 > 19	AC-0067	1826578 2126752	78	78	66	66	1948
LINCON MKZ	06 >	AC-0142	AE5Z4R602A 8E5Z4R602A 7E5Z4R602B 7E5Z4R602A	60,3	79	84,9	104,7	2015

N.B.: I CODICI O.E. ED IL LORO TESTO SONO RIPORTATI SOLO A TITOLO INDICATIVO
THE O.E. CODES AND THEIR TEXT ARE REPORTED ONLY FOR INDICATIVE PURPOSE

APPLICAZIONE (APPLICATION)	ANNO (YEAR)	CODICE (CODE)	O.E. (OR. NUMB.)	DIAMETRO (DIAMETER)				LUNGH. (LENGH.)
				EST. 1 (EXT. 1)	EST. 2 (EXT. 2)	FORO 1 (HOLE 1)	FORO 2 (HOLE 2)	
CR-V I (RD)	95 > 01	AC-0073	40100S10003 40100S10A01	57,12	57,12	69,8	69,8	2098
CR-V II (RD)	02 > 07	AC-0070	40100S9AE01 40100S9AJ01 40100SCAA01	57,12	57,12	69,8	69,8	2051
CR-V II (RD)	02 > 07	AC-0080	40100SWAA01 40100SWYE01 40100SXSA01	57,12		69,8		2058
CR-V III (RE)	06 > 12	AC-0080	40100SWAA01 40100SWYE01 40100SXSA01	57,12		69,8		2058
CR-V IV (RE)	12 >	AC-0133	06400T0A305 40100T0AA01 40100T0AA02 40100T1EE01	57,12	57,12	69,8	69,8	2075
PILOT	08 >	AC-0145	40100SZAA01 40100SZAA02	57,1	57,1	100	100	2200

N.B.: I CODICI O.E. ED IL LORO TESTO SONO RIPORTATI SOLO A TITOLO INDICATIVO
THE O.E. CODES AND THEIR TEXT ARE REPORTED ONLY FOR INDICATIVE PURPOSE

APPLICAZIONE (APPLICATION)	ANNO (YEAR)	CODICE (CODE)	O.E. (OR. NUMB.)	DIAMETRO (DIAMETER)				LUNGH. (LENGH.)
				EST. 1 (EXT. 1)	EST. 2 (EXT. 2)	FORO 1 (HOLE 1)	FORO 2 (HOLE 2)	
H-1 TRAVEL	11 >	AC-0144	491004H100 491004H150	50	40	90		2095
H-1 - STAREX	96 > 00	AC-0068	491004A952					
H-1 - STAREX	96 > 00	AC-0085	491004A970					
ix35	10 > 15	AC-0042	493003W000	16	45	90	90	1986
ix35	10 > 15	AC-0110	493002S000	16	45	90	90	1980
TUCSON	04 > 10	AC-0110	493002S000	16	45	90	90	1980

N.B.: I CODICI O.E. ED IL LORO TESTO SONO RIPORTATI SOLO A TITOLO INDICATIVO
THE O.E. CODES AND THEIR TEXT ARE REPORTED ONLY FOR INDICATIVE PURPOSE

APPLICAZIONE (APPLICATION)	ANNO (YEAR)	CODICE (CODE)	O.E. (OR. NUMB.)	DIAMETRO (DIAMETER)				LUNGH. (LENGH.)
				EST. 1 (EXT. 1)	EST. 2 (EXT. 2)	FORO 1 (HOLE 1)	FORO 2 (HOLE 2)	
CHEROKEE (KJ) (ALESAGGIO: 8 mm.)	01 > 08	AC-0016	52111594AA 52111596AA 52111596AB	100	100	86	86	743
CHEROKEE (KJ)	01 > 08	AC-0017	52111597AA	100	100	86	86	762
COMMANDER (XK)	05 > 10	AC-0091	52105760AB 52105760AC 52105760AD	54,85	16	115	100	973
COMMANDER (XK)	05 > 10	AC-0094	52105758AB 52105758AC 52105758AD	100	65	86	95	778
COMMANDER (XK) (LATO POSTERIORE)	05 > 10	AC-0095	52105728AB 52105728AC 52105728AD	100	65	86	95	867
COMMANDER (XK) (LATO POSTERIORE)	05 > 10	AC-0126	52105726AC	125	140	12	12	1115
COMPASS	07 > 17	AC-0121	05273310AA 05273310AB					2020
GR. CHEROKEE II (WG - WJ)	98 > 05	AC-0119	52099499AG					804 840
GR. CHEROKEE II (WG - WJ)	98 > 05	AC-0120	52099498 52099498AB					844
GR. CHEROKEE III (WH - WK)	05 > 10	AC-0091	52105760AB 52105760AC 52105760AD	54,85	16	115	100	973
GR. CHEROKEE III (WH - WK)	05 > 10	AC-0094	52105758AB 52105758AC 52105758AD	100	65	86	95	778
GR. CHEROKEE III (WH - WK)	05 > 10	AC-0095	52105728AB 52105728AC 52105728AD	100	65	86	95	867
GR. CHEROKEE III (WH - WK) (4,7) - (LATO POSTERIORE)	05 > 10	AC-0126	52105726AC	125	140	12	12	1115

N.B.: I CODICI O.E. ED IL LORO TESTO SONO RIPORTATI SOLO A TITOLO INDICATIVO
THE O.E. CODES AND THEIR TEXT ARE REPORTED ONLY FOR INDICATIVE PURPOSE

APPLICAZIONE (APPLICATION)	ANNO (YEAR)	CODICE (CODE)	O.E. (OR. NUMB.)	DIAMETRO (DIAMETER)				LUNGH. (LENGH.)
				EST. 1 (EXT. 1)	EST. 2 (EXT. 2)	FORO 1 (HOLE 1)	FORO 2 (HOLE 2)	
DISCOVERY II	94 > 04	AC-0015	FTC5320 TVB000100 TVB000110	65	60,3	95	79,4	604
DISCOVERY III (LATO ANTERIORE)	04 > 09	AC-0011	TVB500160 TVB500510	100	100	86	86	688
DISCOVERY III (LATO POSTERIORE)	04 > 09	AC-0019	LR037027 LR037027R TVB500270	99,5	65,35	86	98	1295
DISCOVERY IV (LATO ANTERIORE)	09 > 14	AC-0011	TVB500160 TVB500510	100	100	86	86	688
DISCOVERY IV (LATO POSTERIORE)	09 > 14	AC-0019	LR037027 LR037027R TVB500270	99,5	65,35	86	98	1295
FREELANDER I (314) (LATO ANTERIORE)	98 > 06	AC-0009	FTC5428 TVB000090	95				817
FREELANDER I (314) (LATO POSTERIORE)	98 > 06	AC-0010	FTC5430 TVB000190	57,12	35,8	74,9		880
FREELANDER II	06 > 14	AC-0046	LR001157 LR006959 LR007804	86	86	74	74	1997
RANGE ROVER III	02 > 12	AC-0037	TVB000450	108	99,5	94	86	1272
RANGE ROVER EVOQUE	11 >	AC-0029	LR021552 LR024750 LR031394	86	86	74	74	2002
RANGE ROVER SPORT I (LATO ANTERIORE)	05 > 13	AC-0011	TVB500160 TVB500510	100	100	86	86	688
RANGE ROVER SPORT I (LATO POSTERIORE)	05 > 13	AC-0026	LR037028 TVB500370 TVB500390	99,5	65,35	86	98	1150

N.B.: I CODICI O.E. ED IL LORO TESTO SONO RIPORTATI SOLO A TITOLO INDICATIVO
THE O.E. CODES AND THEIR TEXT ARE REPORTED ONLY FOR INDICATIVE PURPOSE

APPLICAZIONE (APPLICATION)	ANNO (YEAR)	CODICE (CODE)	O.E. (OR. NUMB.)	DIAMETRO (DIAMETER)				LUNGH. (LENGH.)
				EST. 1 (EXT. 1)	EST. 2 (EXT. 2)	FORO 1 (HOLE 1)	FORO 2 (HOLE 2)	
CLASSE C (W204)	11 > 14	AC-0113	2044101801	96		78		660
CLASSE C (W205)	14 >	AC-0006	2044100000	96		78		684
CLASSE C (W205)	14 >	AC-0007	2044107001 2214103401	96		78		671
CLASSE E (W211)	02 > 09	AC-0078	2204107106	57	57	74,4	74,4	610
CLASSE E (W212)	09 > 16	AC-0007	2044107001 2214103401	96		78		671
CLASSE E (W212)	09 > 16	AC-0078	2204107106	57	57	74,4	74,4	610
CLASSE E (W212)	09 > 16	AC-0113	2044101801	96		78		660
CLASSE E (W213)	16 >	AC-0007	2044107001 2214103401	96		78		671
CLASSE GLK (X204)	08 > 15	AC-0113	2044101801	96		78		660
CLASSE M (W163)	98 > 05	AC-0111	1634100301	69,85	97	95,15	86	763
CLASSE M (W163) (TRASMIS. AUTOMATICA)	98 > 05	AC-0076	1634100201 1634100239	69,85	97	95,2	86	674
CLASSE M (W164) (LATO ANTERIORE)	05 > 11	AC-0112	1644100501	95	95	81,2	81,2	620
CLASSE M (W166) (LATO ANTERIORE)	11 > 15	AC-0153	1664100101 1664100501 1664102601 1664103001	95	95	81	81	616

N.B.: I CODICI O.E. ED IL LORO TESTO SONO RIPORTATI SOLO A TITOLO INDICATIVO
THE O.E. CODES AND THEIR TEXT ARE REPORTED ONLY FOR INDICATIVE PURPOSE

APPLICAZIONE (APPLICATION)	ANNO (YEAR)	CODICE (CODE)	O.E. (OR. NUMB.)	DIAMETRO (DIAMETER)				LUNGH. (LENGH.)
				EST. 1 (EXT. 1)	EST. 2 (EXT. 2)	FORO 1 (HOLE 1)	FORO 2 (HOLE 2)	
CLASSE R (W251) (LATO ANTERIORE)	05 > 14	AC-0112	1644100501	95	95	81,2	81,2	620
CLASSE S (W221 - W222)	05 > 17	AC-0113	2044101801	96		78		660
CLS (C218)	11 > 17	AC-0007	2044107001 2214103401	96		78		671
CLS (C218)	11 > 17	AC-0113	2044101801	96		78		660
GL (X164) (LATO ANTERIORE)	06 > 12	AC-0112	1644100501	95	95	81,2	81,2	620
GLA (X156) (TRASMIS. AUTOMATICA)	13 > 20	AC-0043	1764100100 1764100200 2464100000	16	86	80	74	1610 2077
GLE (W166) (LATO ANTERIORE)	15 > 18	AC-0153	1664100101 1664100501 1664102601 1664103001	95	95	81	81	616
GLE COUPE' (C292) (LATO ANTERIORE)	15 > 19	AC-0154	1664102901	95	95	81	81	645
SPRINTER (906)	06 > 17	AC-0027	9064100016	67	67	112	112	2579
SPRINTER (906)	06 > 17	AC-0028	9064100106 9064102016 9064102116	67	67	112	112	2840
SPRINTER (906)	06 > 17	AC-0034	9064103616	16	67	120	112	2805
SPRINTER (906) (LATO POSTERIORE)	06 > 17	AC-0063	9064101816 9064104106	67	67	112	112	2755
VIANO (W639)	03 >	AC-0049	6394103206	57	57	101,6	101,6	2211

N.B.: I CODICI O.E. ED IL LORO TESTO SONO RIPORTATI SOLO A TITOLO INDICATIVO
THE O.E. CODES AND THEIR TEXT ARE REPORTED ONLY FOR INDICATIVE PURPOSE

APPLICAZIONE (APPLICATION)	ANNO (YEAR)	CODICE (CODE)	O.E. (OR. NUMB.)	DIAMETRO (DIAMETER)				LUNGH. (LENGH.)
				EST. 1 (EXT. 1)	EST. 2 (EXT. 2)	FORO 1 (HOLE 1)	FORO 2 (HOLE 2)	
VIANO (W639)	03 >	AC-0050	6394103306	57	57	101,6	101,6	2440
VIANO (W639)	03 >	AC-0051	6394103406	57	57	101,6	101,6	2143
VIANO (W639)	03 >	AC-0052	6394103506	57	57	101,5	101,5	2372
VIANO (W639)	03 >	AC-0053	6394103606	57	57	101,6	101,6	2174,5
VIANO (W639)	03 >	AC-0054	6394103706	57	57	101,6	101,6	2403,5
VIANO (W639)	03 >	AC-0055	6394103906	57	57	101,6	101,6	2174,5
VIANO (W639)	03 >	AC-0057	6394104606	57	57	101,6	101,6	1951
VIANO (W639)	03 >	AC-0058	6394104706	57	57	101,6	101,6	2180
VIANO (W639)	03 >	AC-0059	6394104806	57	57	101,6	101,6	1903
VIANO (W639)	03 >	AC-0060	6394104906	57	57	101,6	101,6	2132
VIANO (W639)	03 >	AC-0064	6394107206	57	57	101,6	101,6	2372
VIANO (W639)	03 >	AC-0065	6394103516	57	57	101,6	101,6	2399
VIANO (W639)	03 >	AC-0066	6394103416	16	57	120	101,6	2171

N.B.: I CODICI O.E. ED IL LORO TESTO SONO RIPORTATI SOLO A TITOLO INDICATIVO
THE O.E. CODES AND THEIR TEXT ARE REPORTED ONLY FOR INDICATIVE PURPOSE

APPLICAZIONE (APPLICATION)	ANNO (YEAR)	CODICE (CODE)	O.E. (OR. NUMB.)	DIAMETRO (DIAMETER)				LUNGH. (LENGH.)
				EST. 1 (EXT. 1)	EST. 2 (EXT. 2)	FORO 1 (HOLE 1)	FORO 2 (HOLE 2)	
VITO (W639)	03 >	AC-0047	6394103106	57	57	101,6	101,6	2240
VITO (W639)	03 >	AC-0048	6394103106	57	57	101,6	101,6	2469
VITO (W639)	03 >	AC-0049	6394103206	57	57	101,6	101,6	2211
VITO (W639)	03 >	AC-0050	6394103306	57	57	101,6	101,6	2440
VITO (W639)	03 >	AC-0051	6394103406	57	57	101,6	101,6	2143
VITO (W639)	03 >	AC-0052	6394103506	57	57	101,5	101,5	2372
VITO (W639)	03 >	AC-0053	6394103606	57	57	101,6	101,6	2174,5
VITO (W639)	03 >	AC-0054	6394103706	57	57	101,6	101,6	2403,5
VITO (W639)	03 >	AC-0055	6394103906	57	57	101,6	101,6	2174,5
VITO (W639)	03 >	AC-0056	6394104006 6394104506	57	57	101,6	101,6	2403,5
VITO (W639)	03 >	AC-0057	6394104606	57	57	101,6	101,6	1951
VITO (W639)	03 >	AC-0058	6394104706	57	57	101,6	101,6	2180
VITO (W639)	03 >	AC-0059	6394104806	57	57	101,6	101,6	1903

N.B.: I CODICI O.E. ED IL LORO TESTO SONO RIPORTATI SOLO A TITOLO INDICATIVO
THE O.E. CODES AND THEIR TEXT ARE REPORTED ONLY FOR INDICATIVE PURPOSE

APPLICAZIONE (APPLICATION)	ANNO (YEAR)	CODICE (CODE)	O.E. (OR. NUMB.)	DIAMETRO (DIAMETER)				LUNGH. (LENGH.)
				EST. 1 (EXT. 1)	EST. 2 (EXT. 2)	FORO 1 (HOLE 1)	FORO 2 (HOLE 2)	
L200 (K0_T - K1_T - K2_T - K3_T)	86 > 96	AC-0143	MR410558 MR518285 MR580388	45	39,6	104,9		862
L200 (K6_T - K7_T) (LATO POSTERIORE)	96 > 05	AC-0036	3401A448 MN168569	45	42,7	104,6		1469
L200 (K6_T - K7_T) (LATO ANTERIORE)	96 > 05	AC-0143	MR410558 MR518285 MR580388	45	39,6	104,9		862
L200 (KA_T - KB_T) (LATO POSTERIORE)	07 > 15	AC-0036	3401A448 MN168569	45	42,7	104,6		1469
L200 (KA_T - KB_T) (LATO ANTERIORE)	07 > 15	AC-0143	MR410558 MR518285 MR580388	45	39,6	104,9		862
L200 (KJ) (LATO ANTERIORE)	15 > 23	AC-0161	3401B041	65	45	95	79,4	764
L300 (P0_W - P1_W - P2_W) (LATO ANTERIORE)	83 > 06	AC-0143	MR410558 MR518285 MR580388	45	39,6	104,9		862
PAJERO I - II (LATO ANTERIORE)	83 > 00	AC-0143	MR410558 MR518285 MR580388	45	39,6	104,9		862
PAJERO III (LATO ANTERIORE)	00 > 06	AC-0157	MR453515 MR580390	45	39,6	104,9		890
PAJERO III - IV (LATO ANTERIORE)	00 >	AC-0143	MR410558 MR518285 MR580388	45	39,6	104,9		862
PAJERO III - IV (LATO ANTERIORE)	00 >	AC-0148	MR410559 MR453516 MR580389	45	39,6	104,9		882
PAJERO III - IV (LATO POSTERIORE)	06 > 12	AC-0152	3401A018	42,7	89,84		107,1	940
OUTLANDER II	06 > 12	AC-0100	3401A022	46	42,7	77,8		2060

N.B.: I CODICI O.E. ED IL LORO TESTO SONO RIPORTATI SOLO A TITOLO INDICATIVO
THE O.E. CODES AND THEIR TEXT ARE REPORTED ONLY FOR INDICATIVE PURPOSE

APPLICAZIONE (APPLICATION)	ANNO (YEAR)	CODICE (CODE)	O.E. (OR. NUMB.)	DIAMETRO (DIAMETER)				LUNGH. (LENGH.)
				EST. 1 (EXT. 1)	EST. 2 (EXT. 2)	FORO 1 (HOLE 1)	FORO 2 (HOLE 2)	
CABSTAR E (2,5 dCl - 3,0 dCl) LATO ANTERIORE	98 > 06	AC-0108	37300F3600					1063
MURANO II - III (Z51 - Z52)	13 >	AC-0134	370001AA0A 370001AA1A	50	65	81,32	95	2182
NP300 NAVARA (D22 - D40) (2,5 dCl - 3,0 dCl) LATO ANTERIORE	07/05 >	AC-0005	37200EB30A 37200EB300 372005X30A	50	50	81,3	81,3	790
PATHFINDER II (R50) (3,3 - 3,5) - TRASMIS. AUTOM. LATO ANTERIORE	96 > 04	AC-0097	659480					609
PATHFINDER III (R51) (2,5 dCl - 3,0 dCl) LATO ANTERIORE	05 > 12	AC-0005	37200EB30A 37200EB300 372005X30A	50	50	81,3	81,3	790
QASHQAI (J10)	06 > 13	AC-0039	37000BR52A 37000JD200	50	65	81,3	95	2017,5
QASHQAI (J10)	06 > 13	AC-0040	37000BR50A 37000BR50B	50	65	81,3	95	1984
QASHQAI (J10)	06 > 13	AC-0041	37000BR51A 37000JD000 37000JG70A	50	65	81,3	95	1999
QASHQAI (J10)	06 > 13	AC-0033	37000JY00C	105	113			2038
QASHQAI (J10)	06 > 13	AC-0074	370004BA2A 37000JM13A	46	65	81,32	95	2219
ROGUE	07 >	AC-0086	37000JM100 37000-JM13A	50	65	81,3	95	2041
SERENA (C23) (LATO POSTERIORE) (N. DENTI: 24)	93 > 01	AC-0106	370007C001	35	50		81,25	672
SERENA (C23) (LATO POSTERIORE) (N. DENTI: 24)	93 > 01	AC-0107	370007C002	35	50		81,25	767

N.B.: I CODICI O.E. ED IL LORO TESTO SONO RIPORTATI SOLO A TITOLO INDICATIVO
THE O.E. CODES AND THEIR TEXT ARE REPORTED ONLY FOR INDICATIVE PURPOSE

APPLICAZIONE (APPLICATION)	ANNO (YEAR)	CODICE (CODE)	O.E. (OR. NUMB.)	DIAMETRO (DIAMETER)				LUNGH. (LENGH.)
				EST. 1 (EXT. 1)	EST. 2 (EXT. 2)	FORO 1 (HOLE 1)	FORO 2 (HOLE 2)	
SERENA (C23) (LATO POSTERIORE) (N. DENTI: 24)	93 > 01	AC-0105	370007C003	35	50		81,25	832
VANETTE CARGO (HC23) (LATO POSTERIORE) (N. DENTI: 24)	94 > 01	AC-0106	370007C001	35			81,25	672
VANETTE CARGO (HC23) (LATO POSTERIORE) (N. DENTI: 24)	94 > 01	AC-0107	370007C002	35	50		81,25	767
VANETTE CARGO (HC23) (LATO POSTERIORE) (N. DENTI: 24)	94 > 01	AC-0105	370007C003	35	50		81,25	832
X-TRAIL (T30)	01 > 06	AC-0109	370008H310	50	50	81,32	81,32	2020
X-TRAIL (T31)	07 > 13	AC-0033	37000JY00C	105	113			2040
X-TRAIL (T31)	07 > 13	AC-0074	370004BA2A 37000JM13A	46	65	81,32	95	2220
X-TRAIL (T32)	13 >	AC-0158	370004BA0A	46	65	81,32	95	2215

N.B.: I CODICI O.E. ED IL LORO TESTO SONO RIPORTATI SOLO A TITOLO INDICATIVO
THE O.E. CODES AND THEIR TEXT ARE REPORTED ONLY FOR INDICATIVE PURPOSE

APPLICAZIONE (APPLICATION)	ANNO (YEAR)	CODICE (CODE)	O.E. (OR. NUMB.)	DIAMETRO (DIAMETER)				LUNGH. (LENGH.)
				EST. 1 (EXT. 1)	EST. 2 (EXT. 2)	FORO 1 (HOLE 1)	FORO 2 (HOLE 2)	
JIMNY (FJ) - (SN) (FORI: 4) - (ALESAGGIO: 10/10 mm.) (LATO ANTERIORE)	98 >	AC-0079	2710282A00	110	110			745
JIMNY (FJ) - (SN) (FORI: 4) - (ALESAGGIO: 8/10 mm.) (LATO POSTERIORE)	98 >	AC-0071	2710384A00	74	45	91	84,5	660
SAMURAI (SJ) (DENTI: 23) (LATO ANTERIORE)	89 >	AC-0098	2710184C00					403,4
SJ 410 - SJ 413 (DENTI: 23) (LATO ANTERIORE)	89 >	AC-0098	2710184C00					403,4
SX4 (LATO POSTERIORE)	06 >15	AC-0102	2710080J11					
SX4 S-CROSS	13 > 22	AC-0038	2710061M00	42	42	73,5	73,5	1980

N.B.: I CODICI O.E. ED IL LORO TESTO SONO RIPORTATI SOLO A TITOLO INDICATIVO
THE O.E. CODES AND THEIR TEXT ARE REPORTED ONLY FOR INDICATIVE PURPOSE

APPLICAZIONE (APPLICATION)	ANNO (YEAR)	CODICE (CODE)	O.E. (OR. NUMB.)	DIAMETRO (DIAMETER)				LUNGH. (LENGH.)
				EST. 1 (EXT. 1)	EST. 2 (EXT. 2)	FORO 1 (HOLE 1)	FORO 2 (HOLE 2)	
HILUX III	05 > 15	AC-0130	371000K030	46	46	93,3	93,3	1616
HILUX III (LATO POSTERIORE)	05 > 15	AC-0131	371100K030					1200
HILUX III (LATO ANTERIORE)	05 > 15	AC-0132	371400K030	46	46	93,3	93,3	597
LAND CRUISER (PZJ7 - KZJ7 - BJ7 - LJ7 - RJ7) (MOD. 2,4 - 2,4 TD - 3,0 TD)	84 > 96	AC-0159	371106A260	46	46	93,3	93,3	1435
LAND CRUISER (PZJ7 - KZJ7 - BJ7 - LJ7 - RJ7) (MOD. 4,2 TD)	84 > 96	AC-0160	3714035190 3714060540	46	46	84,85	84,85	718
LAND CRUISER 100 (UZJ100) (MOD. 4,7) - (LATO POSTERIORE)	98 > 08	AC-0150	371106A020 371106A060 371106A610					1136
LAND CRUISER 100 (UZJ100) (MOD. 4,2 TD) - (LATO POSTERIORE)	98 > 08	AC-0155	371106A620	95	95	81	81	1432
LAND CRUISER (KDJ12 - GRJ12) (MOD. 4,0 V6)	02 > 10	AC-0149	371106A440	46	46	93,34	93,34	1178
LAND CRUISER (KDJ12 - GRJ12) (MOD. 2,8/3,0 D-4D)	02 > 10	AC-0156	3714060410 3714060590	105	105	94	94	765
LAND CRUISER (KDJ15 - GRJ15) (MOD. 4,0 V6)	09 >	AC-0149	371106A440	46	46	93,34	93,34	1178
LAND CRUISER (KDJ15 - GRJ15) (MOD. 2,8/3,0 D-4D)	09 >	AC-0156	3714060410 3714060590	105	105	94	94	765
RAV 4 II	00 > 05	AC-0101	3710042060	46	38	84,8		1980
RAV 4 III	06 > 12	AC-0020	3710042080	74	74	78		2185

N.B.: I CODICI O.E. ED IL LORO TESTO SONO RIPORTATI SOLO A TITOLO INDICATIVO
THE O.E. CODES AND THEIR TEXT ARE REPORTED ONLY FOR INDICATIVE PURPOSE

APPLICAZIONE (APPLICATION)	ANNO (YEAR)	CODICE (CODE)	O.E. (OR. NUMB.)	DIAMETRO (DIAMETER)				LUNGH. (LENGH.)
				EST. 1 (EXT. 1)	EST. 2 (EXT. 2)	FORO 1 (HOLE 1)	FORO 2 (HOLE 2)	
CRAFTER	06 > 17	AC-0028	2E1521293 2E0521101A	67	67	112	112	2840
CRAFTER	06 > 17	AC-0027	2E0521293	67	67	112	112	2579
CRAFTER	06 > 17	AC-0034	9064103616	16	67	120	112	2805
CRAFTER (LATO POSTERIORE)	06 > 17	AC-0063						2755
TIGUAN (5N)	07 > 16	AC-0024	5N0521101C 5N0521101E 5N0521101M	16	16	96	105	2138
TOUAREG (7LA - 7L6 - 7L7) (LATO ANTERIORE)	02 > 10	AC-0013	7L6521101A 7L6521101C 7L6521101E	99,5	99,5	86	86	678
TOUAREG (7LA - 7L6 - 7L7) (LATO ANTERIORE)	02 > 10	AC-0104	7L0521101A 7L0521101B 7L0521101C	99,47	99,47	86	86	632
TOUAREG (7LA - 7L6 - 7L7) (LATO POSTERIORE)	02 > 10	AC-0018	7L0521102B 7L0521102C 7L0521102D	99,5	16	86	110	1225
TOUAREG (7LA - 7L6 - 7L7) (LATO POSTERIORE)	02 > 10	AC-0021	7L6521102B 7L6521102C 7L6521102D	99,5	16	86	110	1165
TOUAREG (7LA - 7L6 - 7L7)	02 > 10	AC-0128	7L8521102D 7L8521102F 7L8521102M	99,5	99,5	86	86	1438
TRANSPORTER V (7JD - JE -JL)	03 > 15	AC-0128	7L8521102D 7L8521102F 7L8521102M	99,5	99,5	86	86	1438

N.B.: I CODICI O.E. ED IL LORO TESTO SONO RIPORTATI SOLO A TITOLO INDICATIVO
THE O.E. CODES AND THEIR TEXT ARE REPORTED ONLY FOR INDICATIVE PURPOSE

IMMAGINI
IMAGES



IMMAGINI - IMAGES

AC-0001

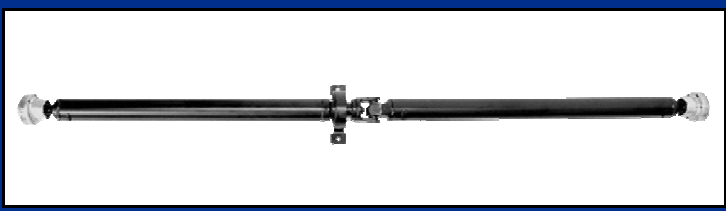

AC-0002



AC-0003



AC-0004



AC-0005

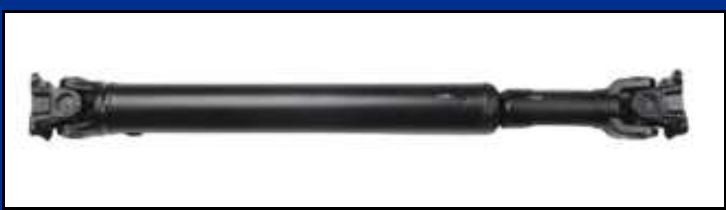

AC-0006

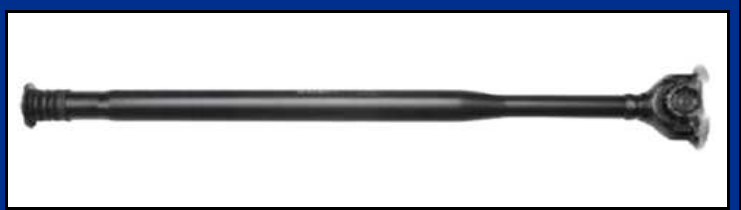

AC-0007



AC-0009



AC-0010

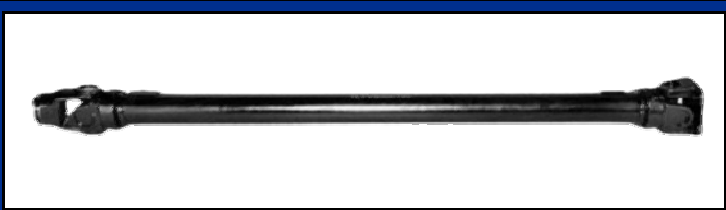

AC-0011

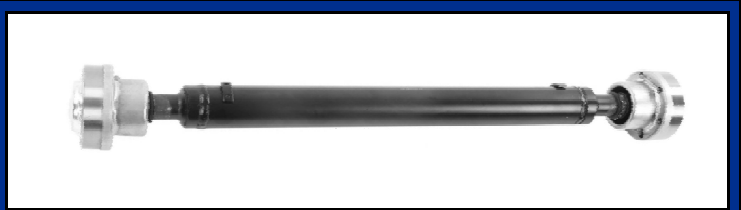

AC-0013



AC-0014



N.B.: I CODICI O.E. ED IL LORO TESTO SONO RIPORTATI SOLO A TITOLO INDICATIVO
 THE O.E. CODES AND THEIR TEXT ARE REPORTED ONLY FOR INDICATIVE PURPOSE

IMMAGINI - IMAGES

AC-0015



AC-0016



AC-0017



AC-0018



AC-0019



AC-0020



AC-0021



AC-0022



AC-0023



AC-0024



AC-0025



AC-0026



N.B.: I CODICI O.E. ED IL LORO TESTO SONO RIPORTATI SOLO A TITOLO INDICATIVO
 THE O.E. CODES AND THEIR TEXT ARE REPORTED ONLY FOR INDICATIVE PURPOSE

IMMAGINI - IMAGES

AC-0027



AC-0028



AC-0029



AC-0032



AC-0033



AC-0034



AC-0035



AC-0036

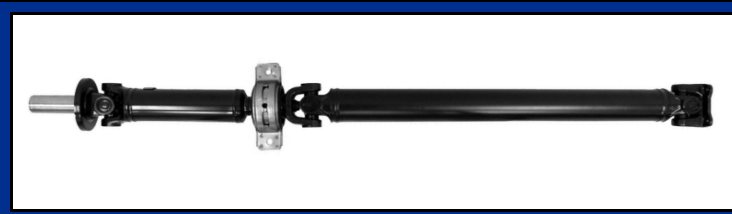

AC-0037



AC-0038



AC-0039



AC-0040

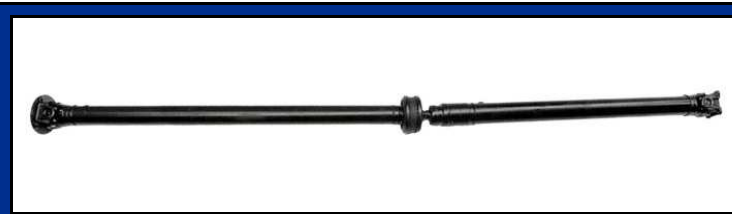

N.B.: I CODICI O.E. ED IL LORO TESTO SONO RIPORTATI SOLO A TITOLO INDICATIVO
 THE O.E. CODES AND THEIR TEXT ARE REPORTED ONLY FOR INDICATIVE PURPOSE

IMMAGINI - IMAGES

AC-0041



AC-0042



AC-0043



AC-0044



AC-0045



AC-0046

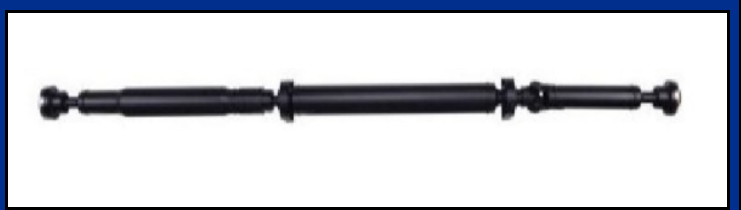

AC-0047



AC-0048



AC-0049



AC-0050



AC-0051



AC-0052



N.B.: I CODICI O.E. ED IL LORO TESTO SONO RIPORTATI SOLO A TITOLO INDICATIVO
 THE O.E. CODES AND THEIR TEXT ARE REPORTED ONLY FOR INDICATIVE PURPOSE

IMMAGINI - IMAGES

AC-0053



AC-0054



AC-0055



AC-0056



AC-0057



AC-0058



AC-0059



AC-0060



AC-0061



AC-0062



AC-0063

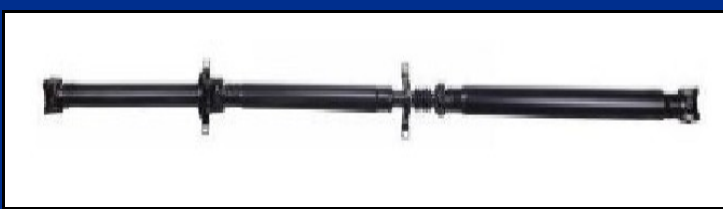

AC-0064



N.B.: I CODICI O.E. ED IL LORO TESTO SONO RIPORTATI SOLO A TITOLO INDICATIVO
 THE O.E. CODES AND THEIR TEXT ARE REPORTED ONLY FOR INDICATIVE PURPOSE

IMMAGINI - IMAGES

AC-0065



AC-0066



AC-0067



AC-0068



AC-0070



AC-0071



AC-0072



AC-0073



AC-0074



AC-0075



AC-0076

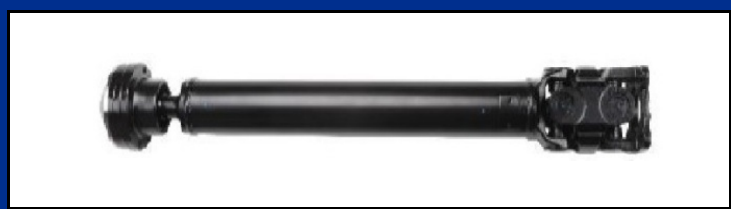

AC-0077



N.B.: I CODICI O.E. ED IL LORO TESTO SONO RIPORTATI SOLO A TITOLO INDICATIVO
 THE O.E. CODES AND THEIR TEXT ARE REPORTED ONLY FOR INDICATIVE PURPOSE

IMMAGINI - IMAGES

AC-0078



AC-0079



AC-0080



AC-0081

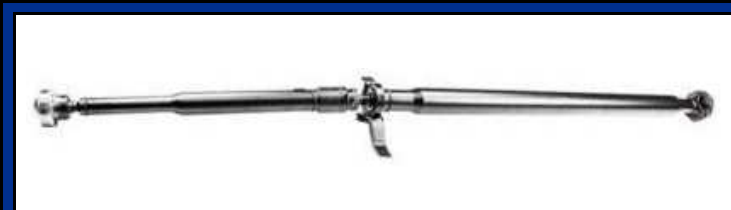

AC-0082



AC-0083



AC-0085

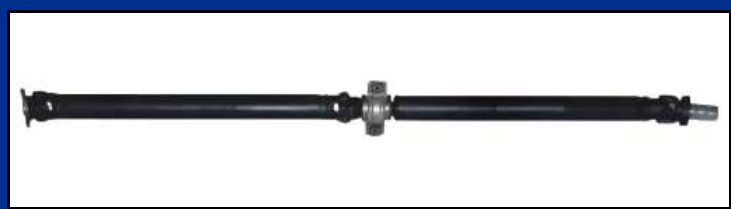

AC-0086



AC-0087



AC-0088



AC-0089



AC-0090



N.B.: I CODICI O.E. ED IL LORO TESTO SONO RIPORTATI SOLO A TITOLO INDICATIVO
 THE O.E. CODES AND THEIR TEXT ARE REPORTED ONLY FOR INDICATIVE PURPOSE

IMMAGINI - IMAGES

AC-0091



AC-0092



AC-0093



AC-0094



AC-0095



AC-0097

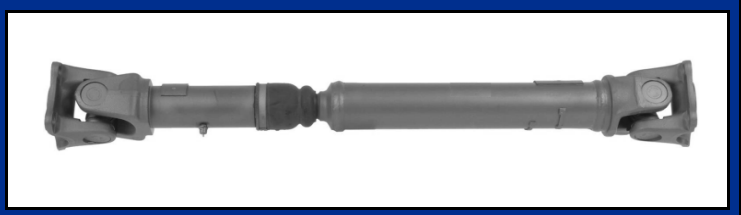

AC-0098



AC-0099



AC-0100



AC-0101



AC-0102



AC-0103

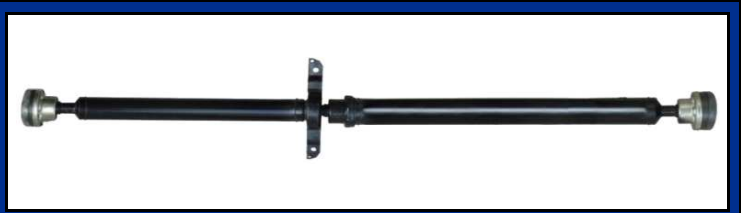

N.B.: I CODICI O.E. ED IL LORO TESTO SONO RIPORTATI SOLO A TITOLO INDICATIVO
 THE O.E. CODES AND THEIR TEXT ARE REPORTED ONLY FOR INDICATIVE PURPOSE

IMMAGINI - IMAGES

AC-0104



AC-0105



AC-0106



AC-0107



AC-0108



AC-0109



AC-0110



AC-0111



AC-0112



AC-0113



AC-0114



AC-0115



N.B.: I CODICI O.E. ED IL LORO TESTO SONO RIPORTATI SOLO A TITOLO INDICATIVO
 THE O.E. CODES AND THEIR TEXT ARE REPORTED ONLY FOR INDICATIVE PURPOSE

IMMAGINI - IMAGES

AC-0116



AC-0117



AC-0118



AC-0119



AC-0120



AC-0121



AC-0123



AC-0124



AC-0125



AC-0126



AC-0127



AC-0128

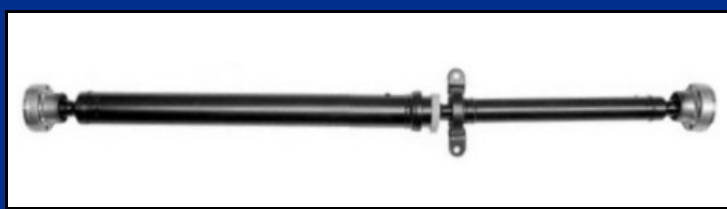

N.B.: I CODICI O.E. ED IL LORO TESTO SONO RIPORTATI SOLO A TITOLO INDICATIVO
 THE O.E. CODES AND THEIR TEXT ARE REPORTED ONLY FOR INDICATIVE PURPOSE

IMMAGINI - IMAGES

AC-0129

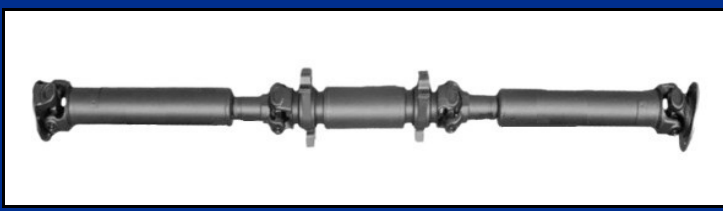

AC-0130

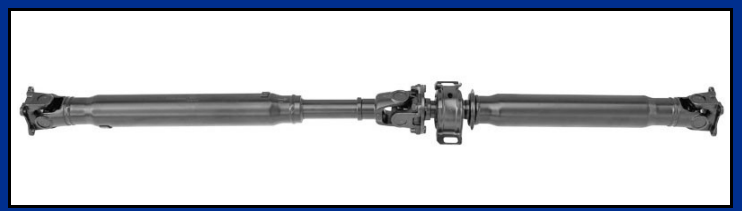

AC-0131



AC-0132



AC-0133



AC-0134



AC-0135



AC-0136



AC-0137



AC-0138



AC-0139



AC-0140

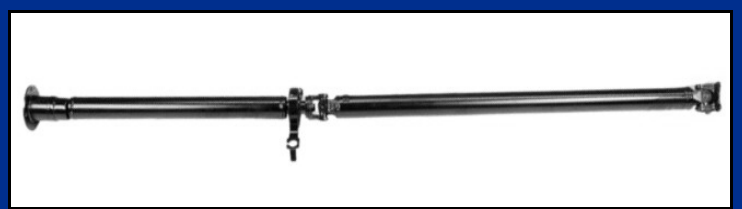

N.B.: I CODICI O.E. ED IL LORO TESTO SONO RIPORTATI SOLO A TITOLO INDICATIVO
 THE O.E. CODES AND THEIR TEXT ARE REPORTED ONLY FOR INDICATIVE PURPOSE

IMMAGINI - IMAGES

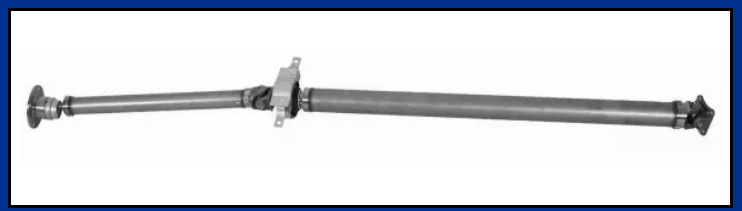
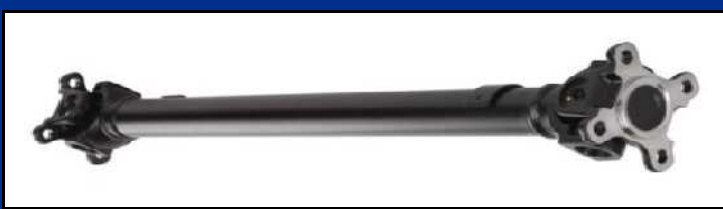
AC-0141**AC-0142****AC-0143****AC-0144****AC-0145****AC-0146****AC-0147****AC-0148****AC-0149****AC-0150****AC-0151****AC-0152**

N.B.: I CODICI O.E. ED IL LORO TESTO SONO RIPORTATI SOLO A TITOLO INDICATIVO
 THE O.E. CODES AND THEIR TEXT ARE REPORTED ONLY FOR INDICATIVE PURPOSE

IMMAGINI - IMAGES

AC-0153



AC-0154



AC-0155



AC-0156



AC-0157



AC-0158



AC-0159



AC-0160



AC-0161



N.B.: I CODICI O.E. ED IL LORO TESTO SONO RIPORTATI SOLO A TITOLO INDICATIVO
 THE O.E. CODES AND THEIR TEXT ARE REPORTED ONLY FOR INDICATIVE PURPOSE

DISEGNI TECNICI
TECHNICAL DRAWINGS



DISEGNI TECNICI - TECHNICAL DRAWINGS

AC-0001

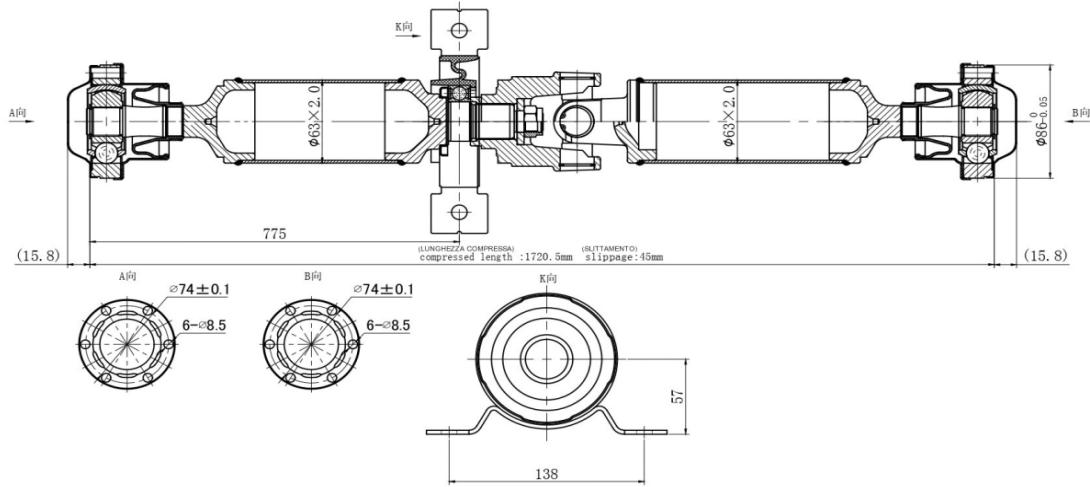

AC-0002

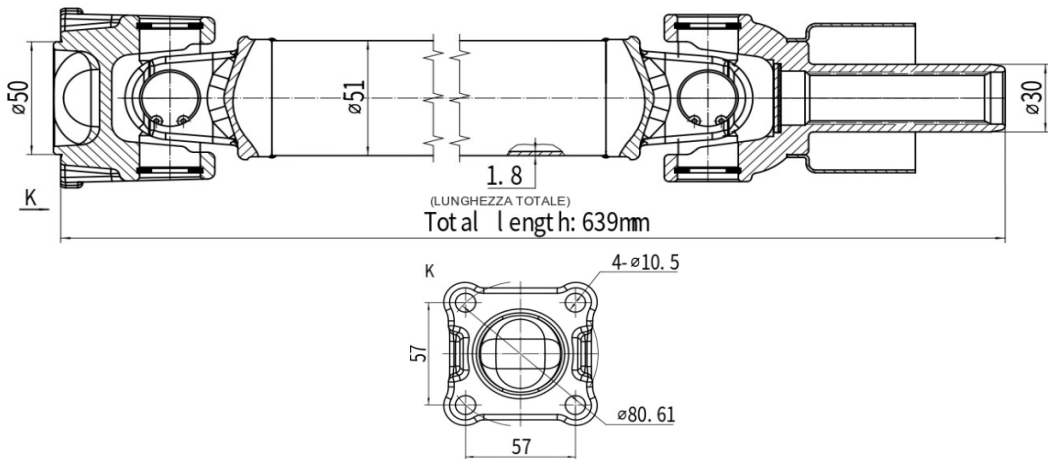

AC-0003

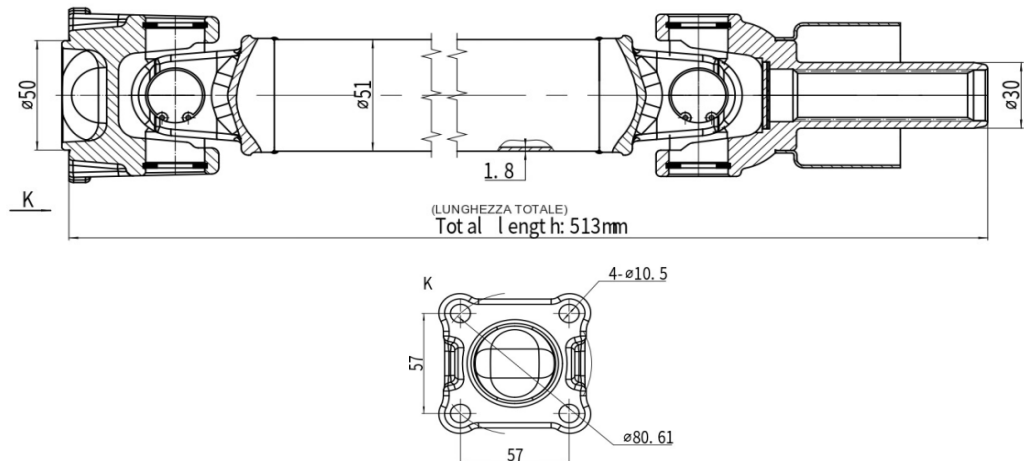

N.B.: I CODICI O.E. ED IL LORO TESTO SONO RIPORTATI SOLO A TITOLO INDICATIVO
THE O.E. CODES AND THEIR TEXT ARE REPORTED ONLY FOR INDICATIVE PURPOSE

DISEGNI TECNICI - TECHNICAL DRAWINGS

AC-0004

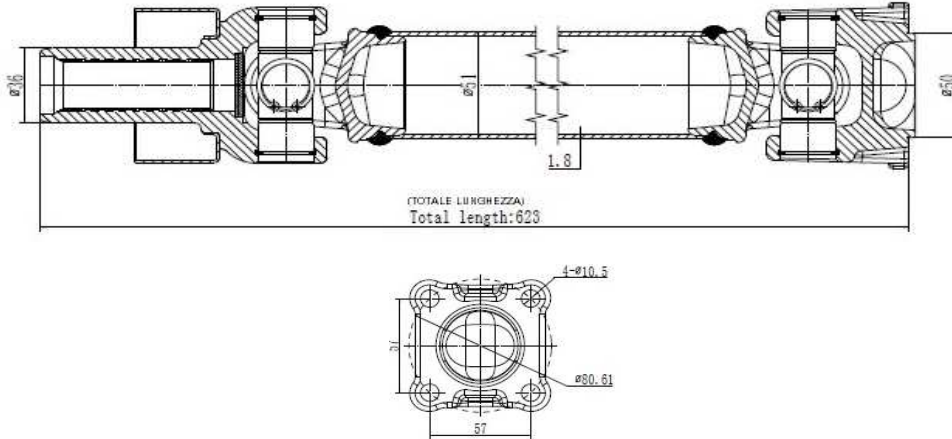

AC-0005

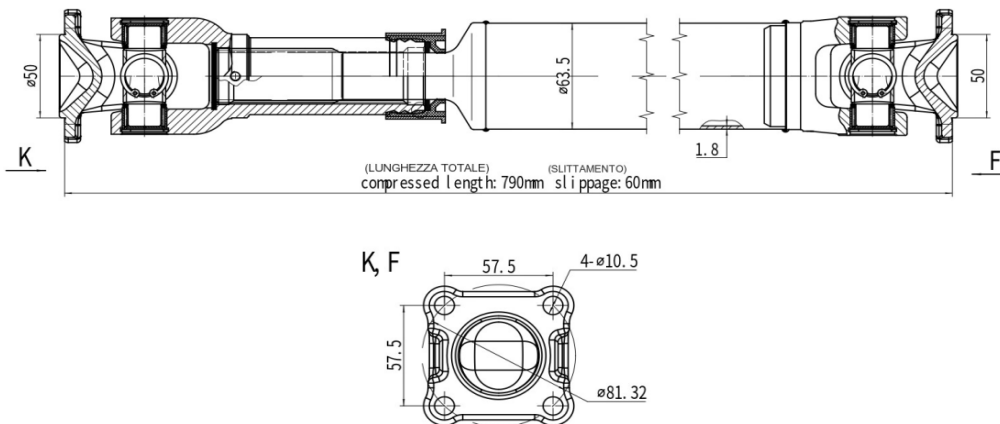

AC-0006

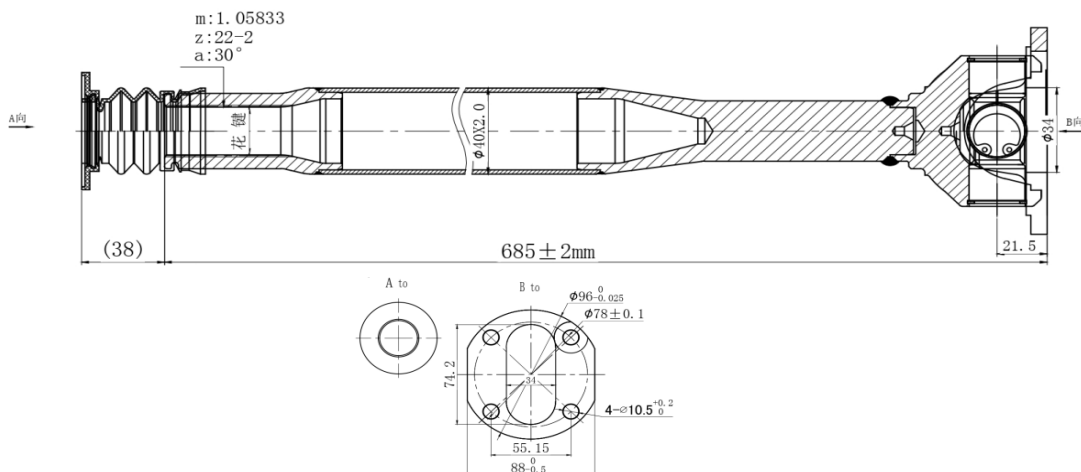

N.B.: I CODICI O.E. ED IL LORO TESTO SONO RIPORTATI SOLO A TITOLO INDICATIVO
THE O.E. CODES AND THEIR TEXT ARE REPORTED ONLY FOR INDICATIVE PURPOSE

DISEGNI TECNICI - TECHNICAL DRAWINGS

AC-0007

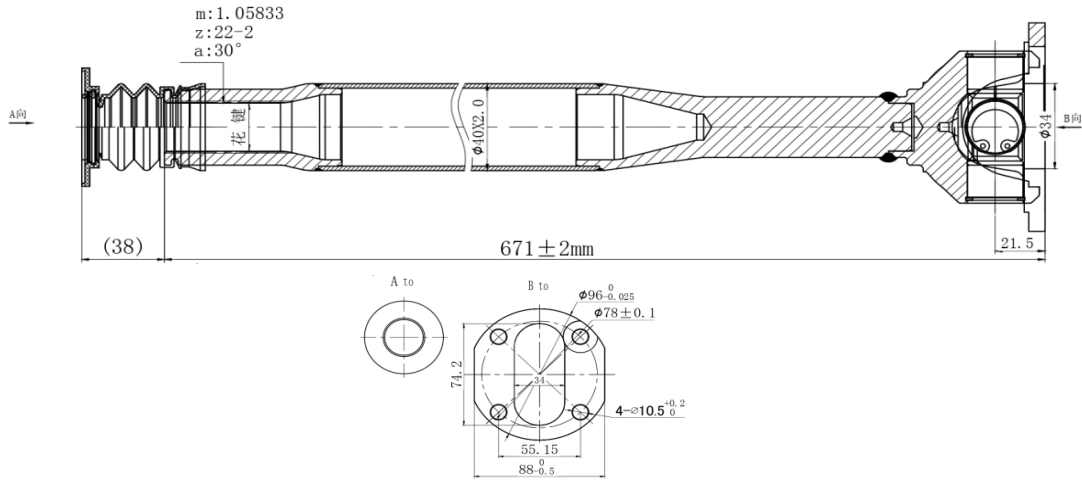

AC-0009

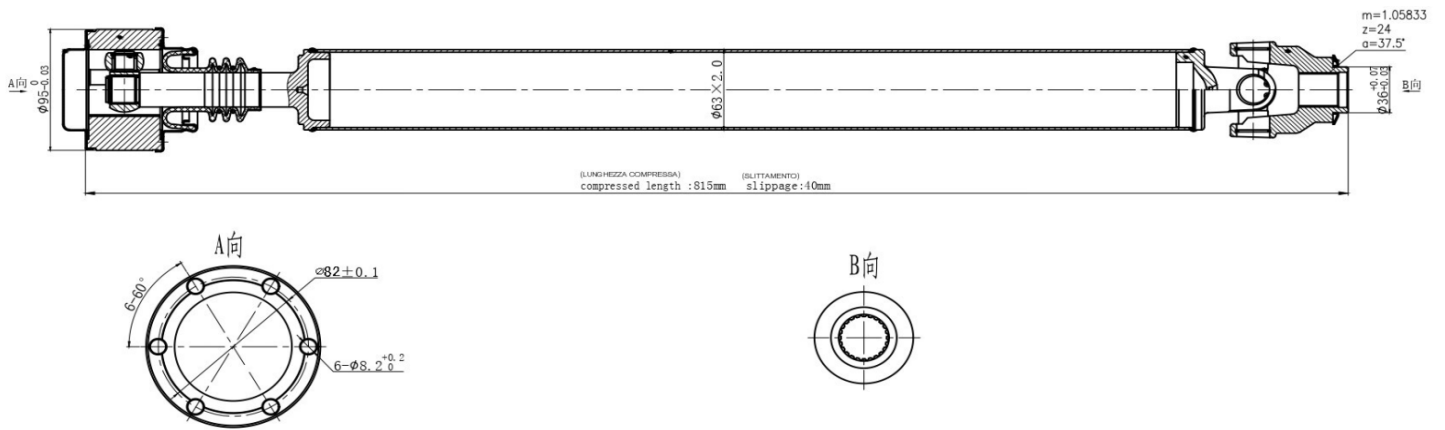

AC-0010

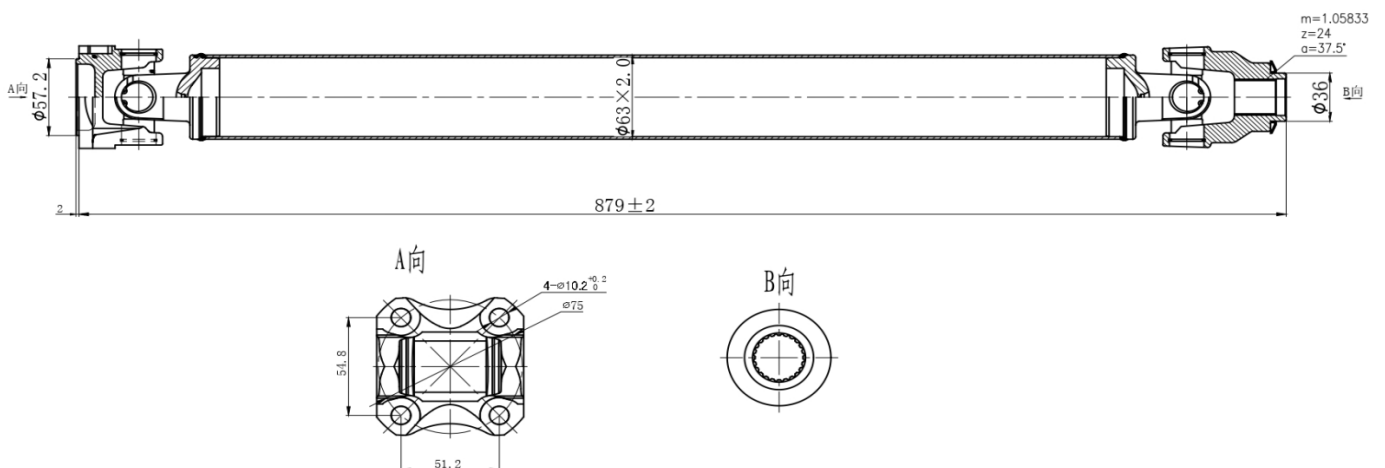

N.B.: I CODICI O.E. ED IL LORO TESTO SONO RIPORTATI SOLO A TITOLO INDICATIVO
 THE O.E. CODES AND THEIR TEXT ARE REPORTED ONLY FOR INDICATIVE PURPOSE

DISEGNI TECNICI - TECHNICAL DRAWINGS

AC-0011

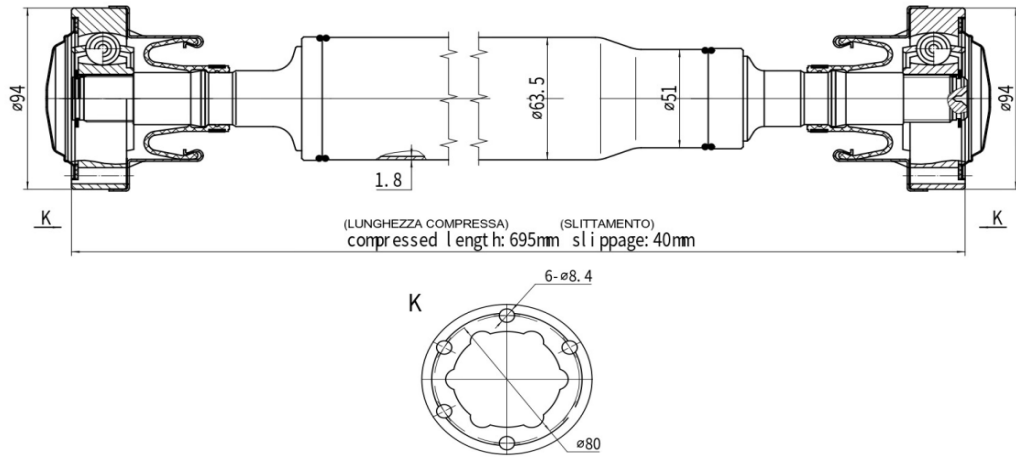

AC-0012

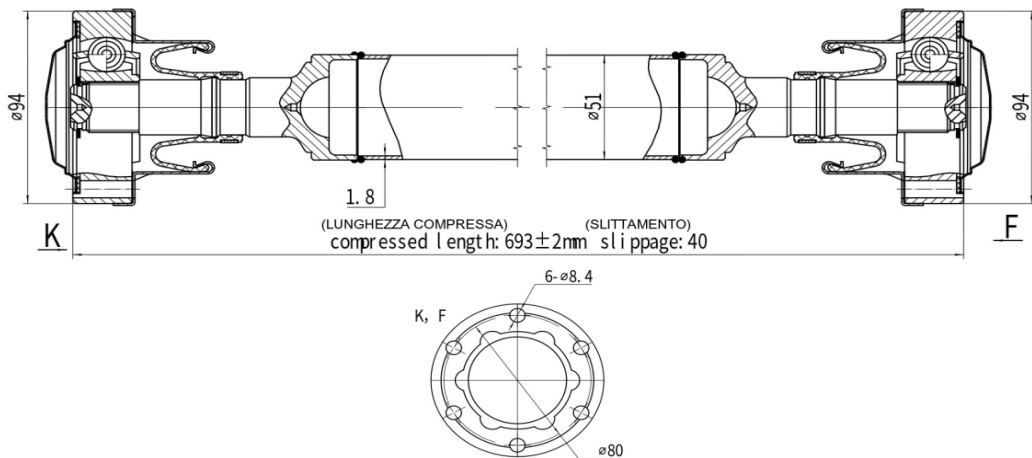

AC-0013

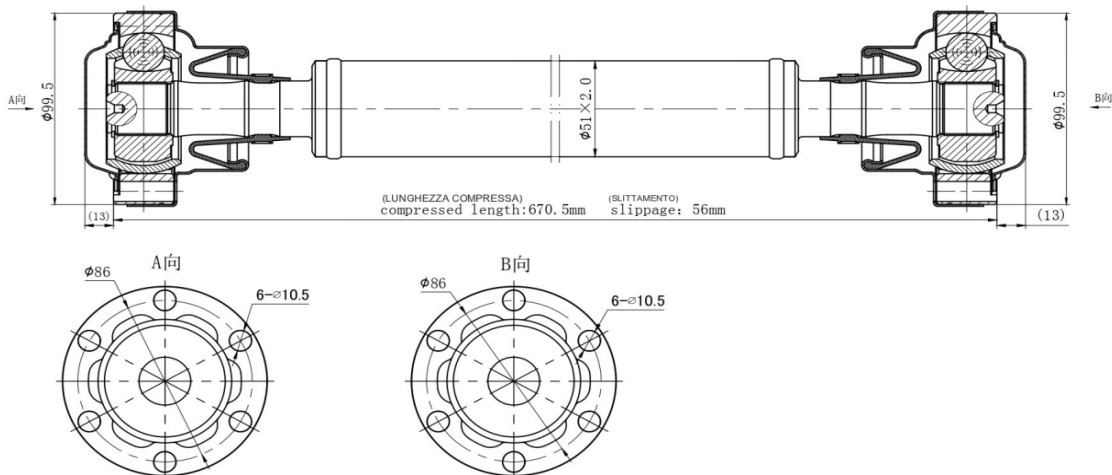

N.B.: I CODICI O.E. ED IL LORO TESTO SONO RIPORTATI SOLO A TITOLO INDICATIVO
THE O.E. CODES AND THEIR TEXT ARE REPORTED ONLY FOR INDICATIVE PURPOSE

DISEGNI TECNICI - TECHNICAL DRAWINGS

AC-0014

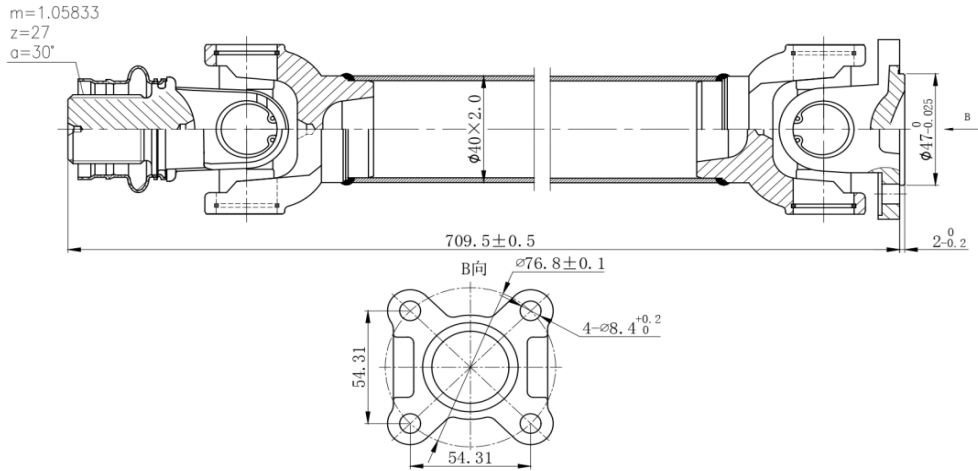

AC-0015

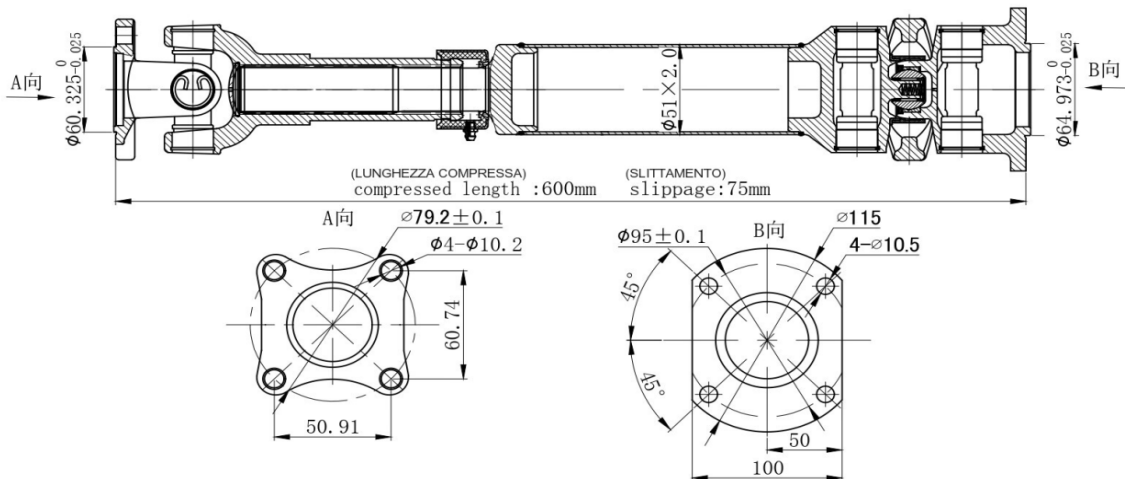

AC-0016

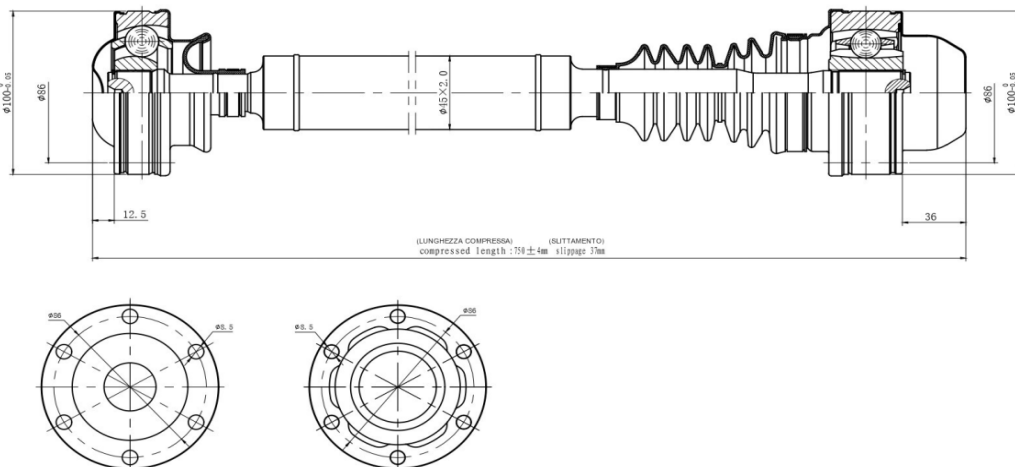

N.B.: I CODICI O.E. ED IL LORO TESTO SONO RIPIRTATI SOLO A TITOLO INDICATIVO
 THE O.E. CODES AND THEIR TEXT ARE REPORTED ONLY FOR INDICATIVE PURPOSE

DISEGNI TECNICI - TECHNICAL DRAWINGS

AC-0017

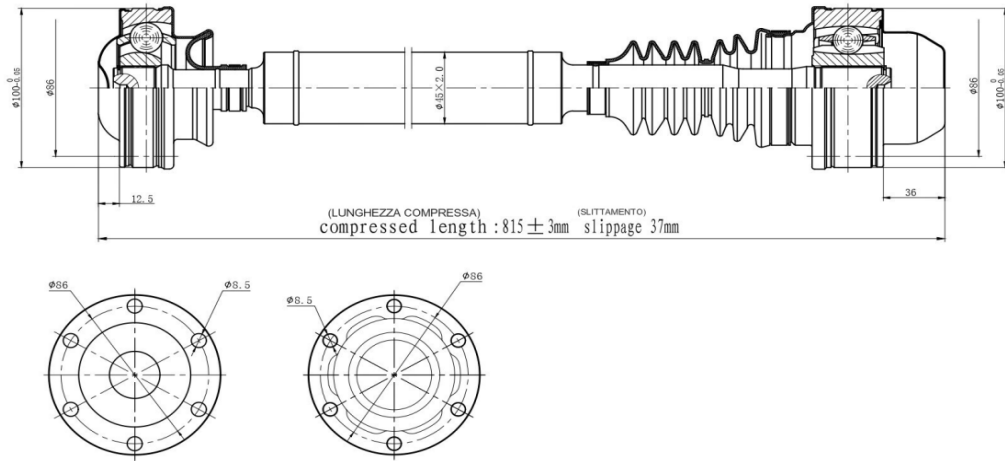

AC-0018

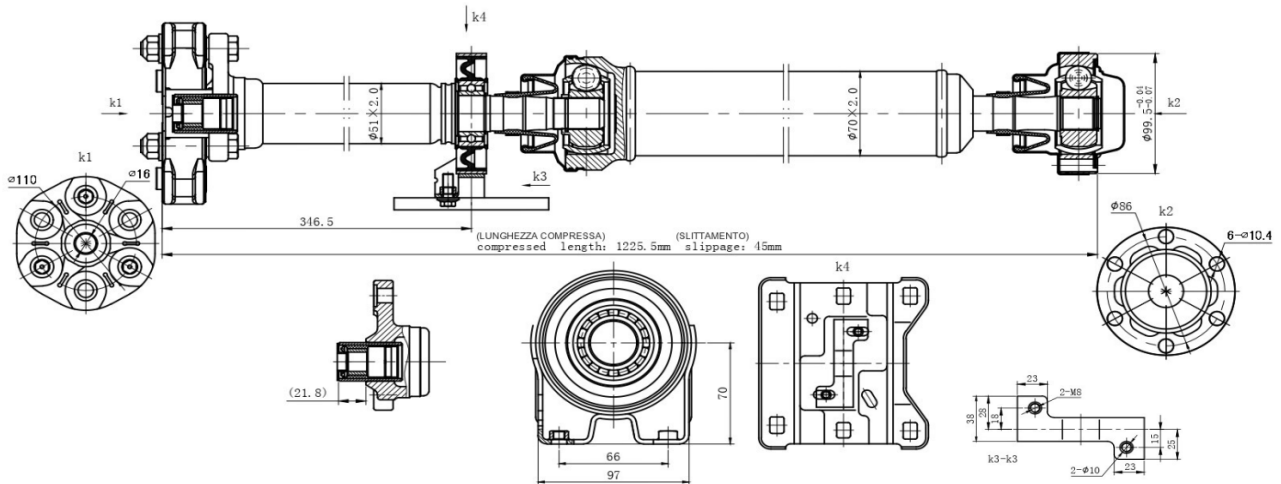

AC-0019

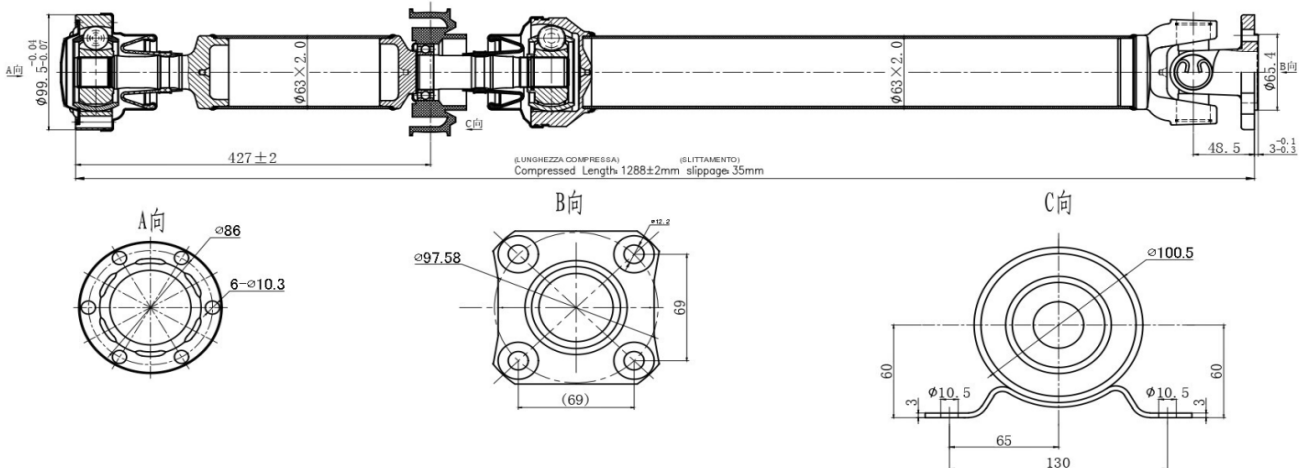

N.B.: I CODICI O.E. ED IL LORO TESTO SONO RIPORTATI SOLO A TITOLO INDICATIVO
 THE O.E. CODES AND THEIR TEXT ARE REPORTED ONLY FOR INDICATIVE PURPOSE

DISEGNI TECNICI - TECHNICAL DRAWINGS

AC-0020

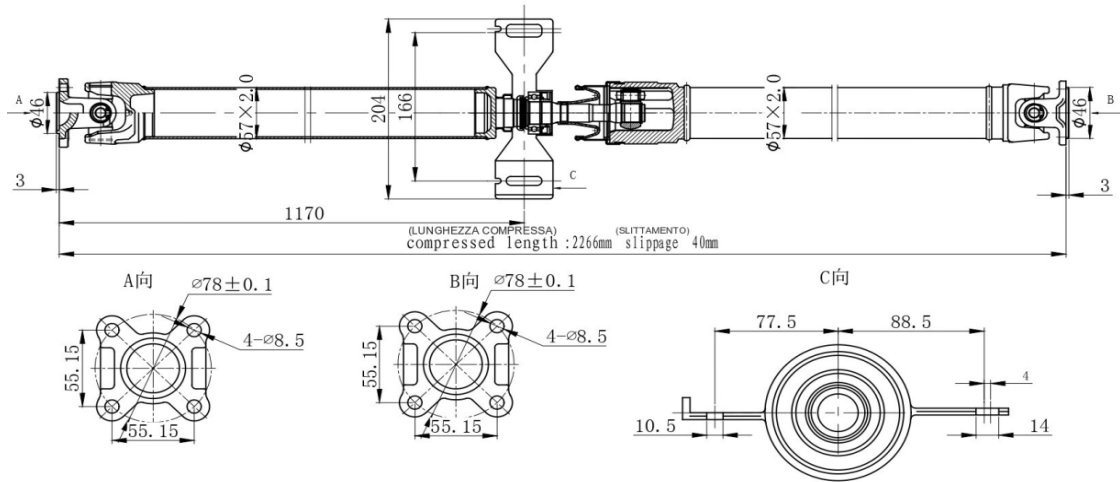

AC-0021

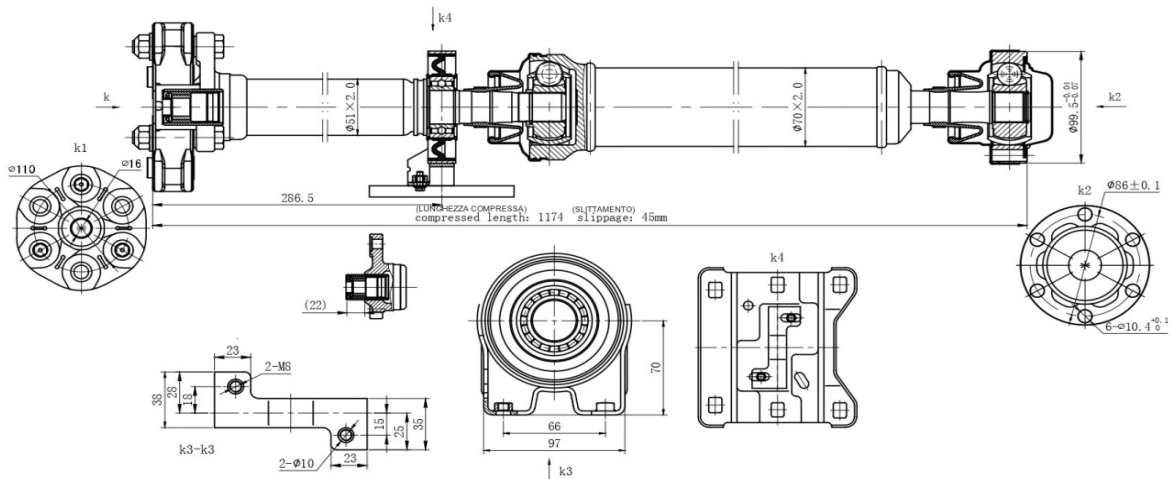

AC-0022

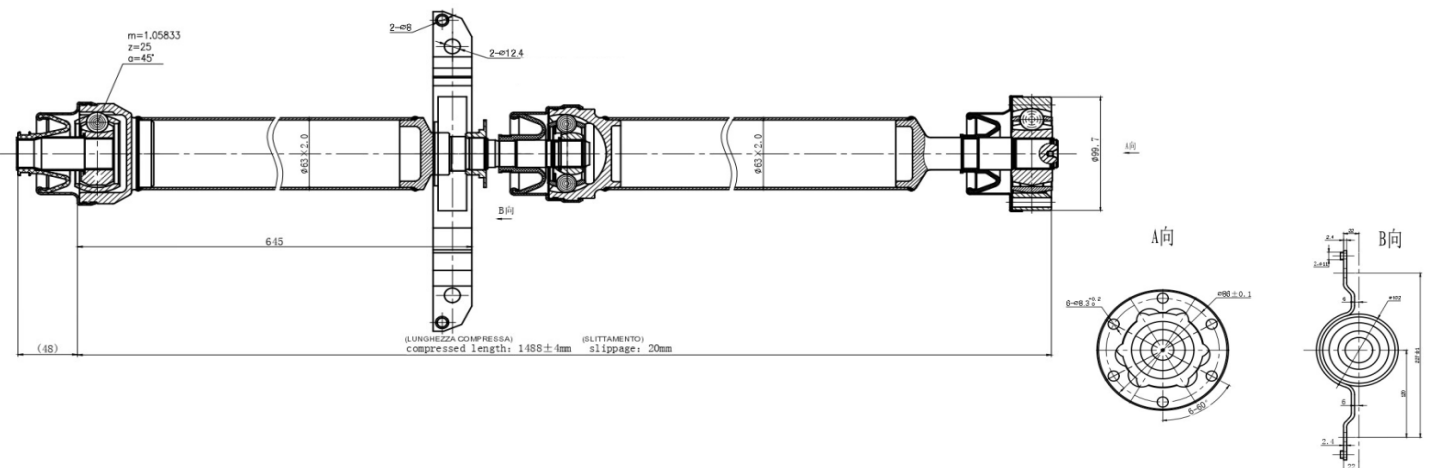

N.B.: I CODICI O.E. ED IL LORO TESTO SONO RIPORTATI SOLO A TITOLO INDICATIVO
 THE O.E. CODES AND THEIR TEXT ARE REPORTED ONLY FOR INDICATIVE PURPOSE

DISEGNI TECNICI - TECHNICAL DRAWINGS

AC-0023

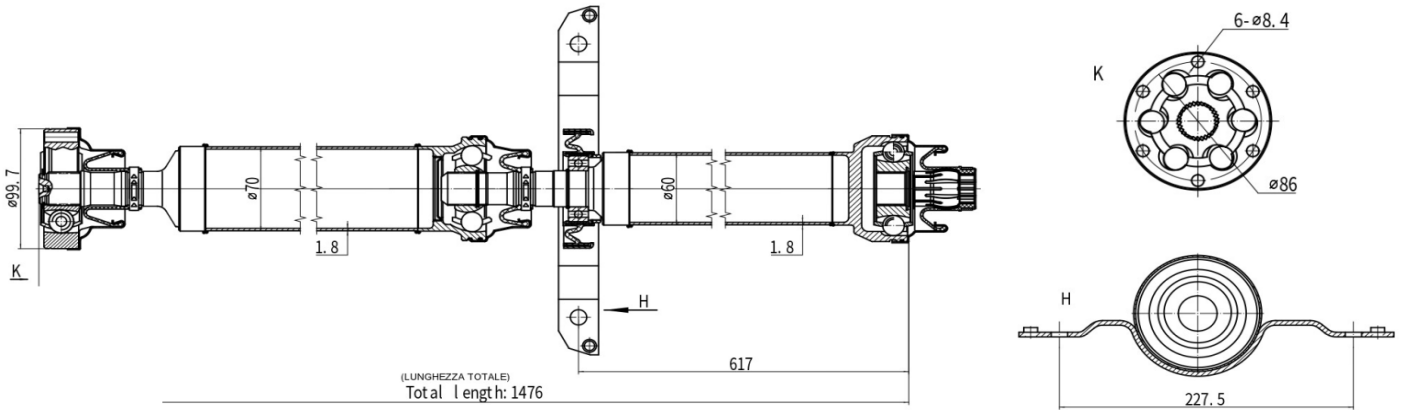

AC-0024

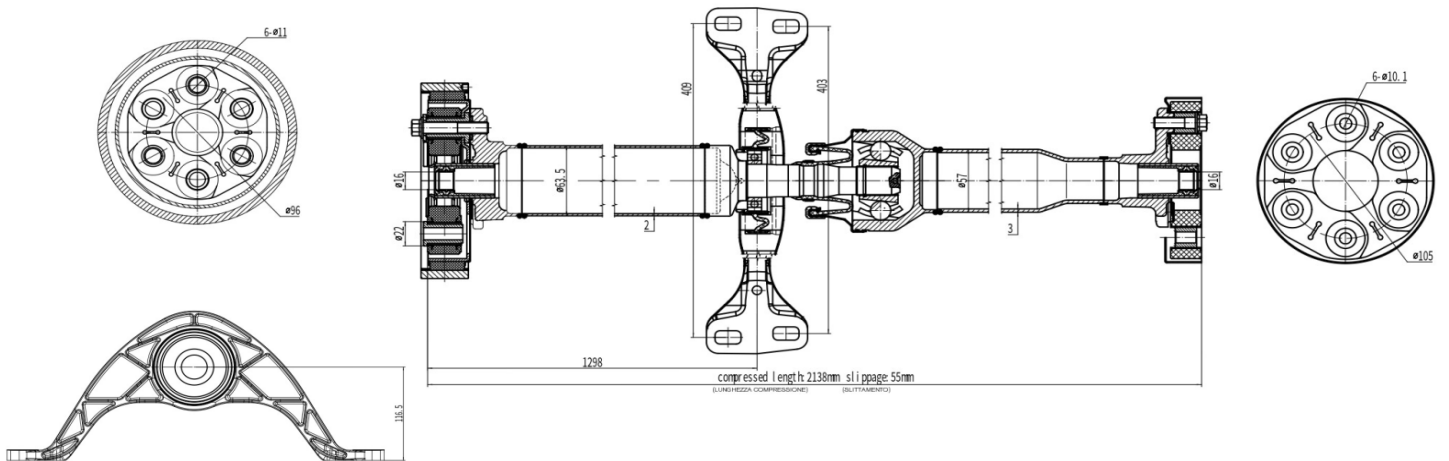

AC-0025

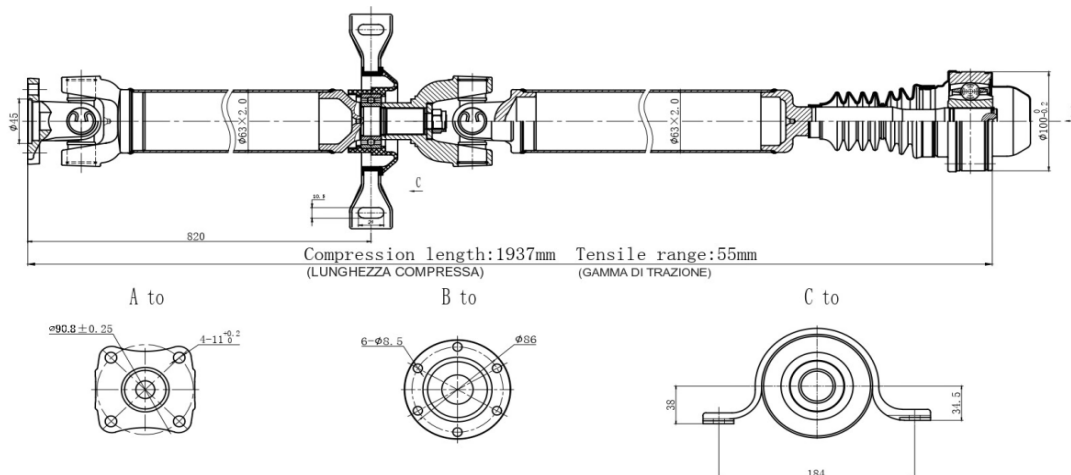

N.B.: I CODICI O.E. ED IL LORO TESTO SONO RIPORTATI SOLO A TITOLO INDICATIVO
THE O.E. CODES AND THEIR TEXT ARE REPORTED ONLY FOR INDICATIVE PURPOSE

DISEGNI TECNICI - TECHNICAL DRAWINGS

AC-0026

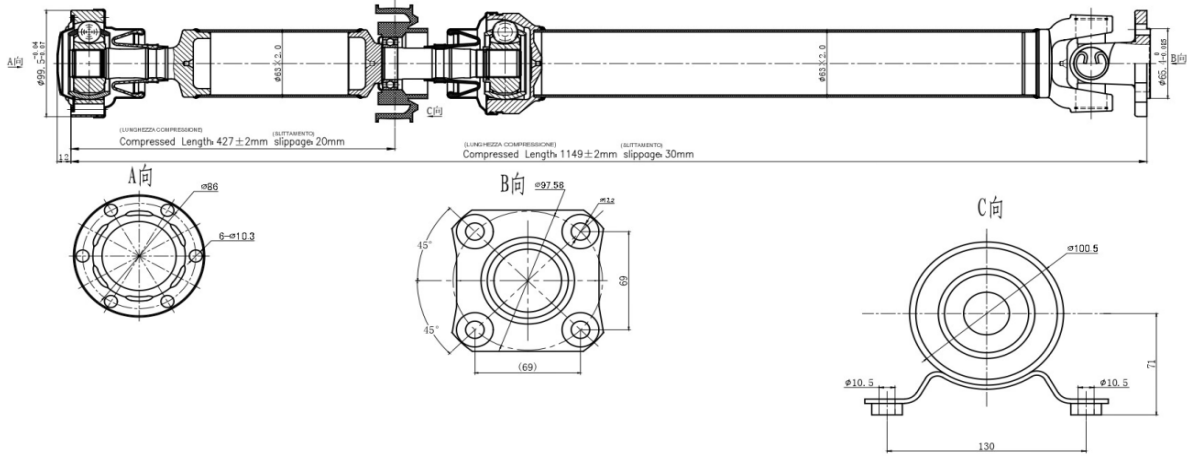

AC-0027

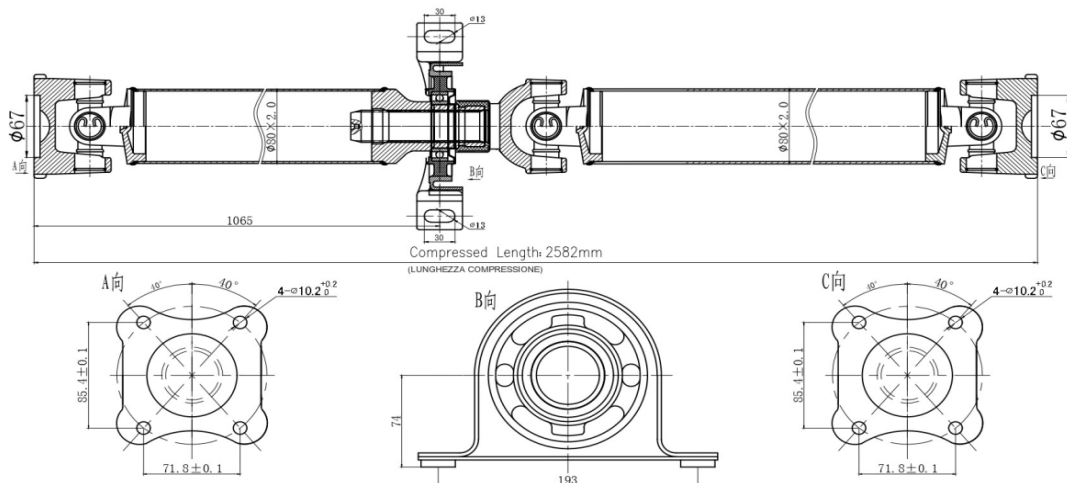

AC-0028

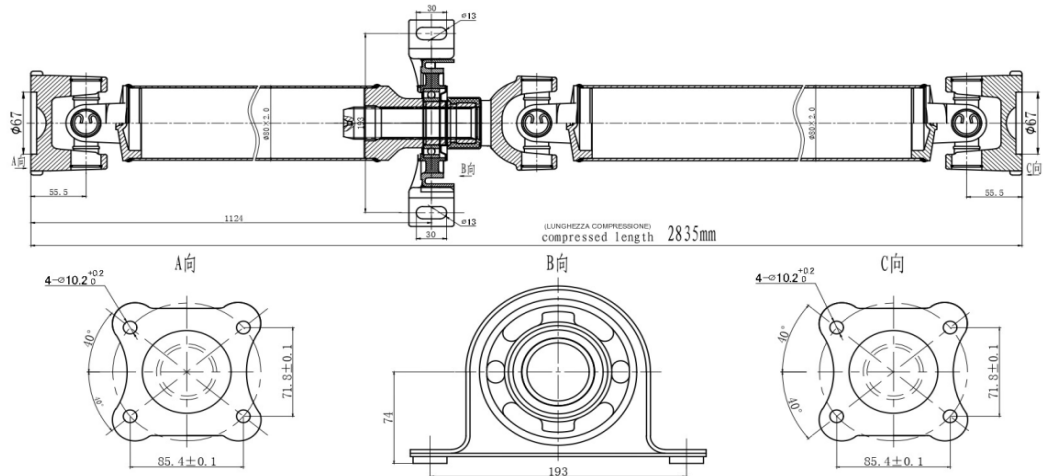

N.B.: I CODICI O.E. ED IL LORO TESTO SONO RIPORTATI SOLO A TITOLO INDICATIVO
 THE O.E. CODES AND THEIR TEXT ARE REPORTED ONLY FOR INDICATIVE PURPOSE

DISEGNI TECNICI - TECHNICAL DRAWINGS

AC-0029

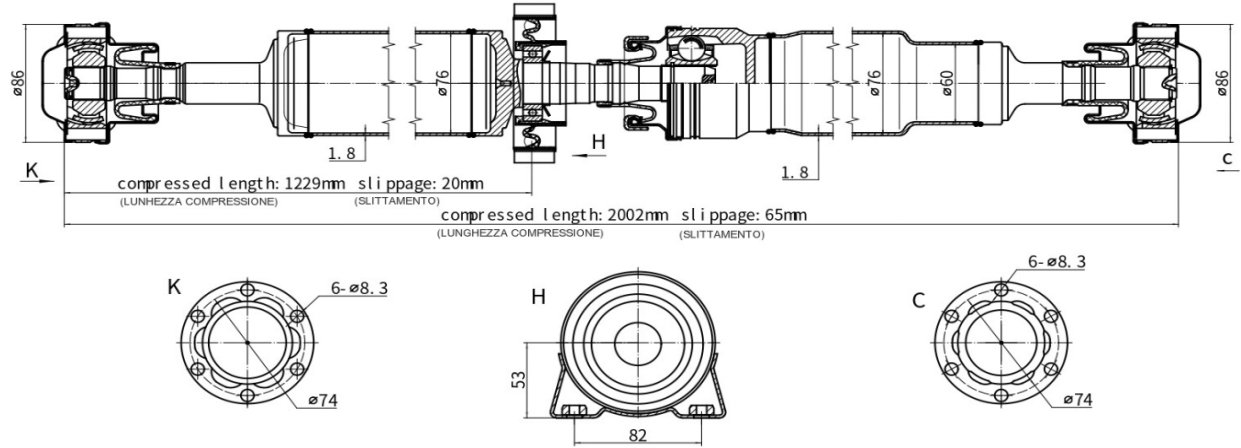

AC-0032

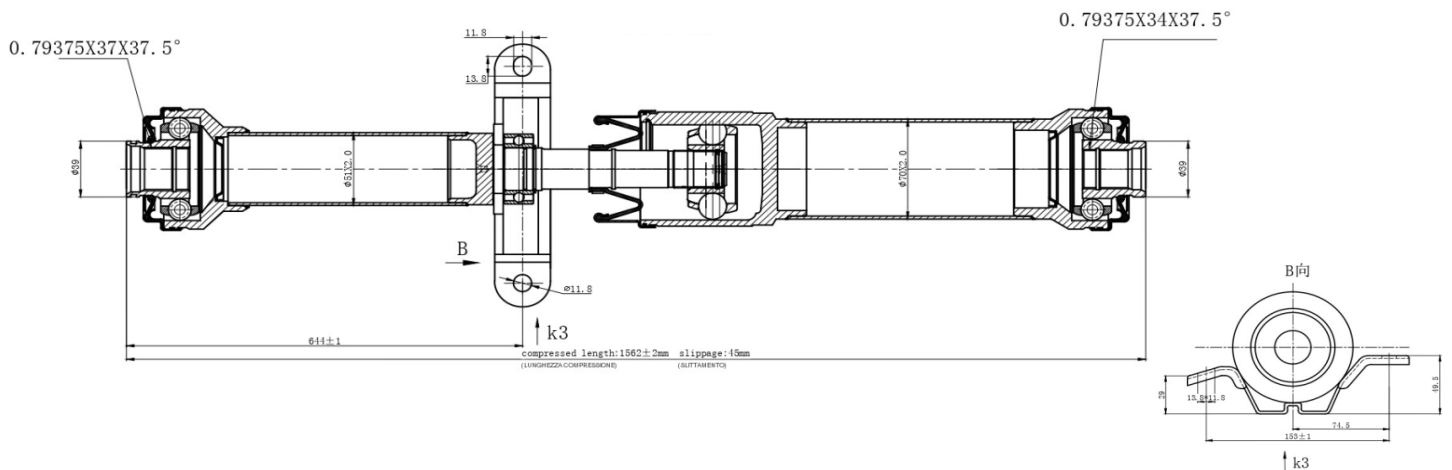

AC-0033

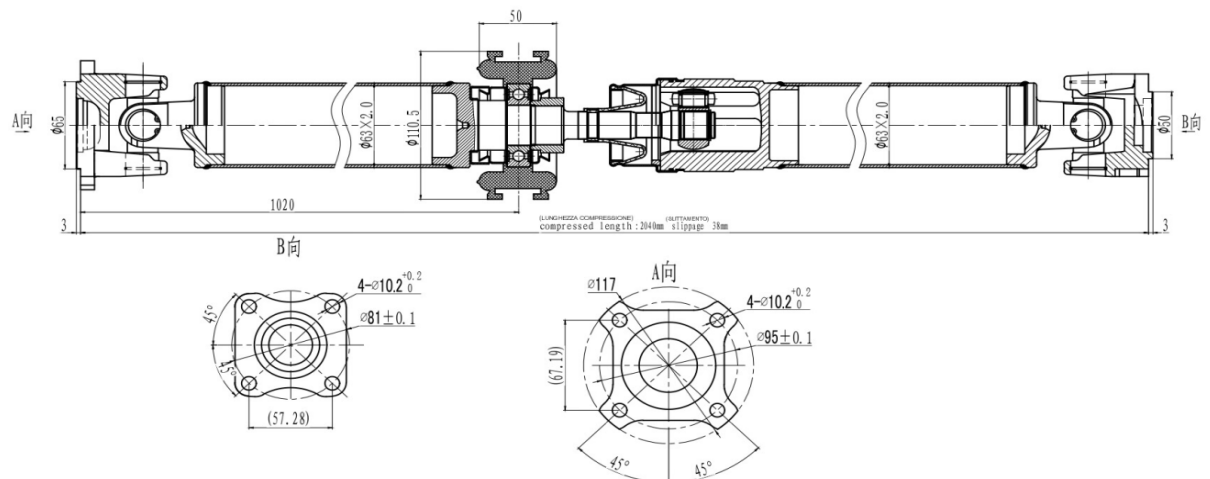

N.B.: I CODICI O.E. ED IL LORO TESTO SONO RIPORTATI SOLO A TITOLO INDICATIVO
 THE O.E. CODES AND THEIR TEXT ARE REPORTED ONLY FOR INDICATIVE PURPOSE

DISEGNI TECNICI - TECHNICAL DRAWINGS

AC-0034

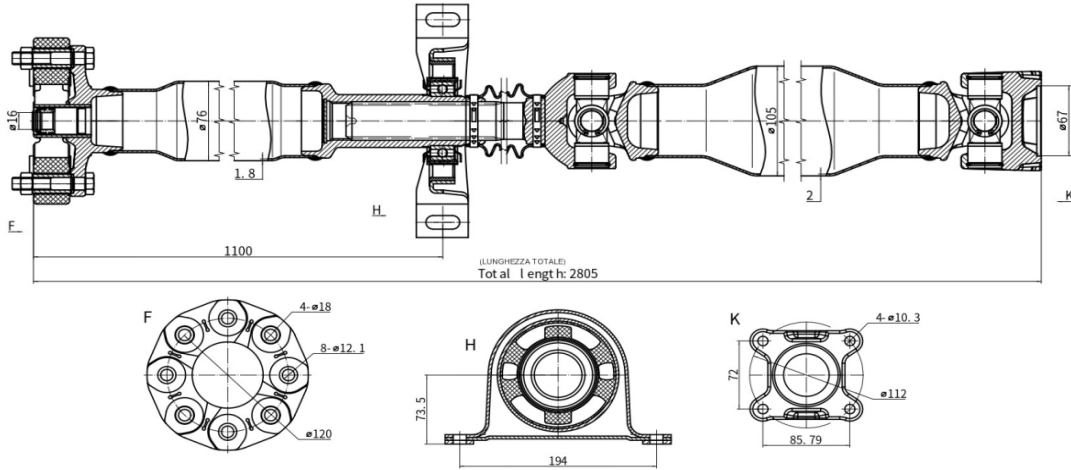

AC-0035

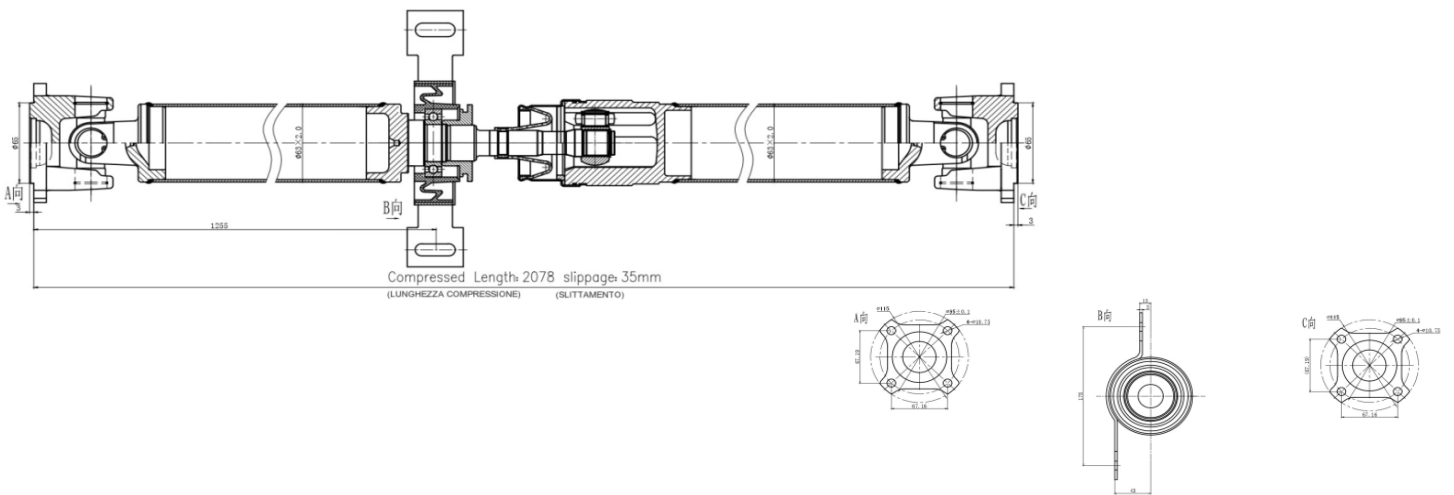

AC-0036

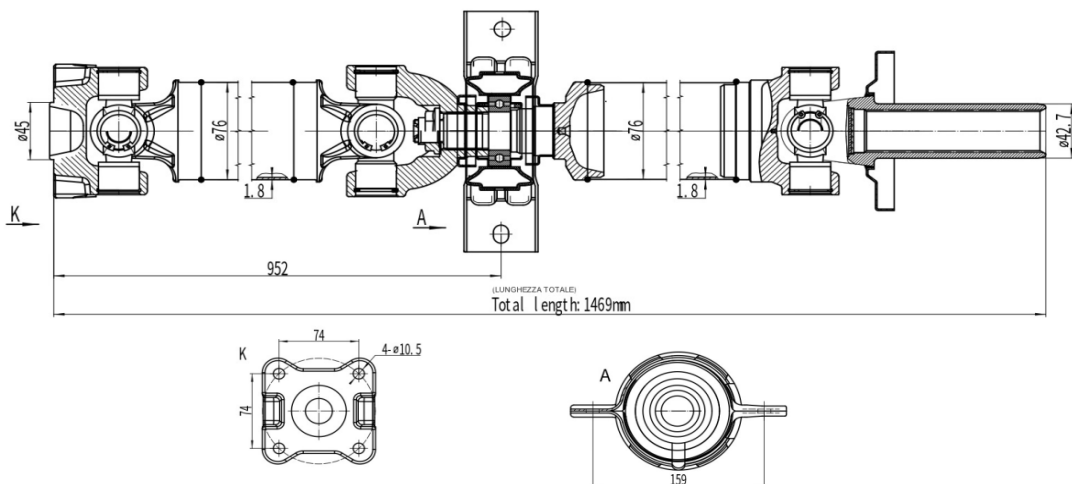

N.B.: I CODICI O.E. ED IL LORO TESTO SONO RIPORTATI SOLO A TITOLO INDICATIVO
 THE O.E. CODES AND THEIR TEXT ARE REPORTED ONLY FOR INDICATIVE PURPOSE

DISEGNI TECNICI - TECHNICAL DRAWINGS

AC-0037

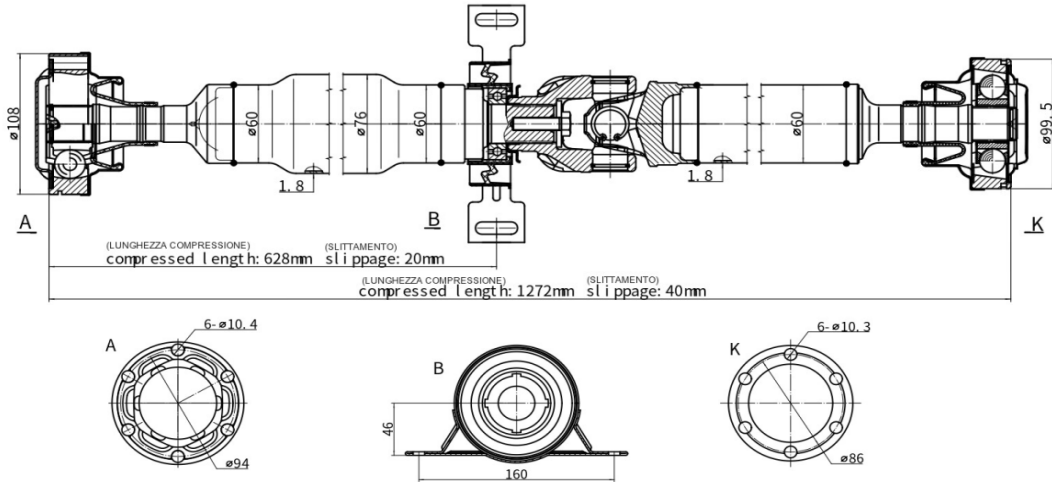

AC-0038

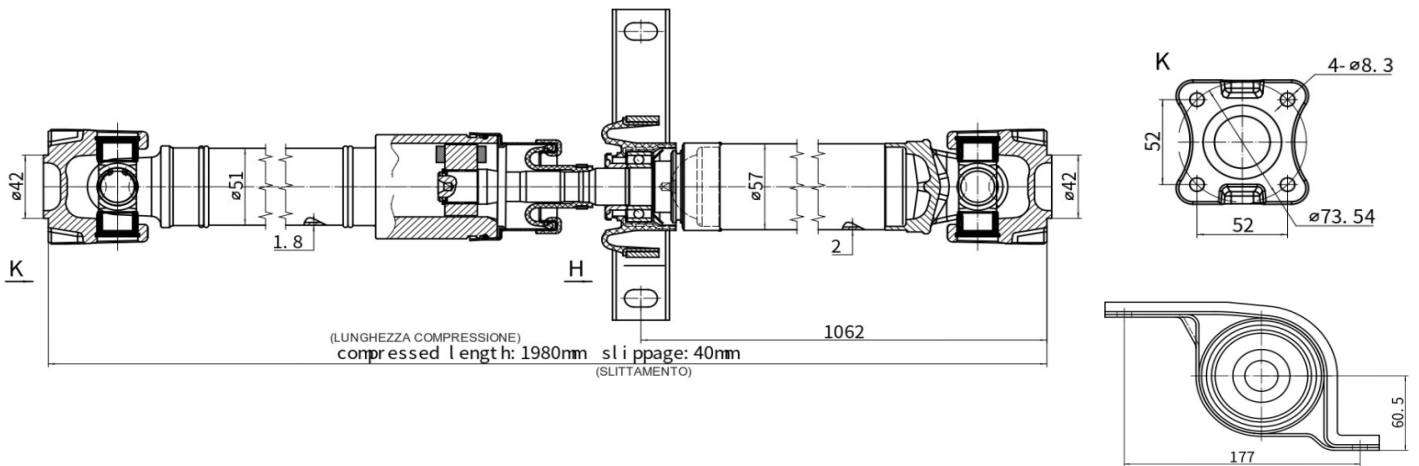

AC-0039

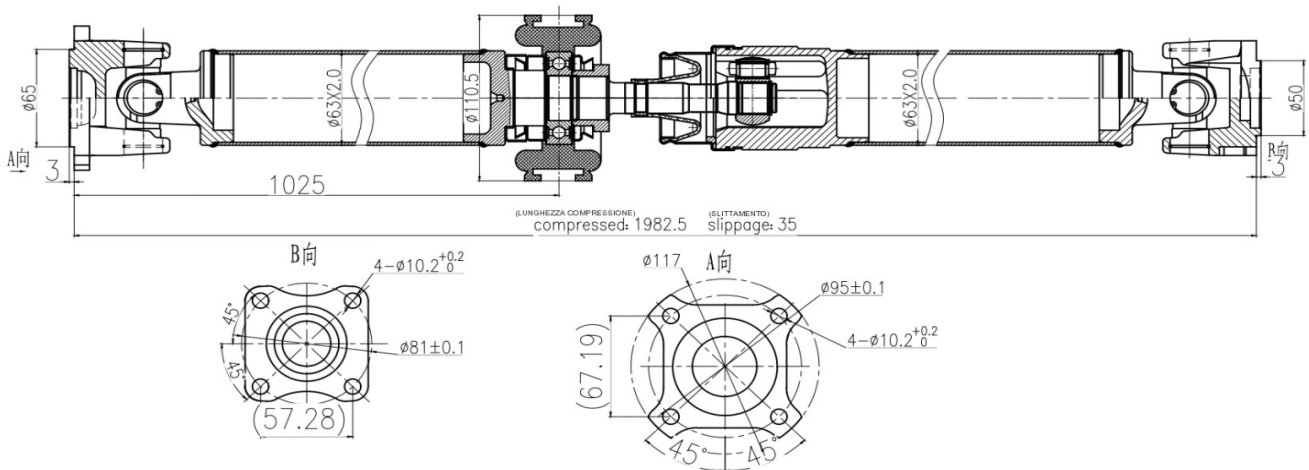

N.B.: I CODICI O.E. ED IL LORO TESTO SONO RIPORTATI SOLO A TITOLO INDICATIVO
 THE O.E. CODES AND THEIR TEXT ARE REPORTED ONLY FOR INDICATIVE PURPOSE

DISEGNI TECNICI - TECHNICAL DRAWINGS

AC-0040

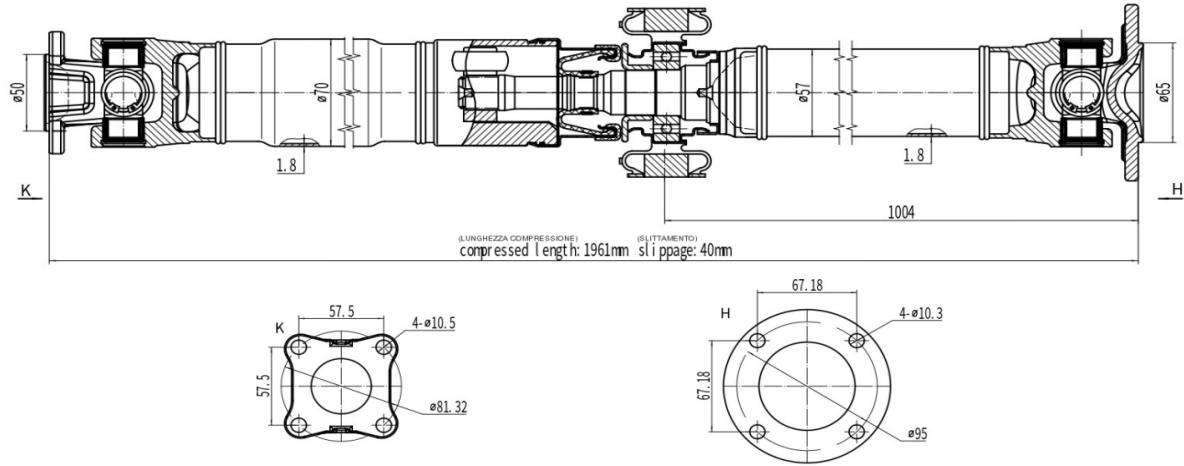

AC-0041

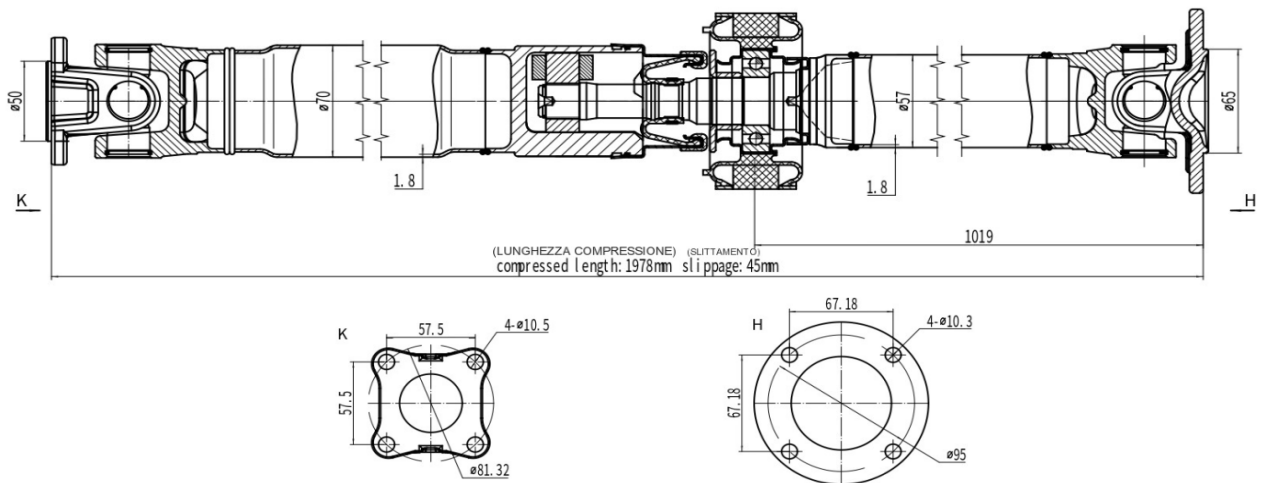

AC-0042

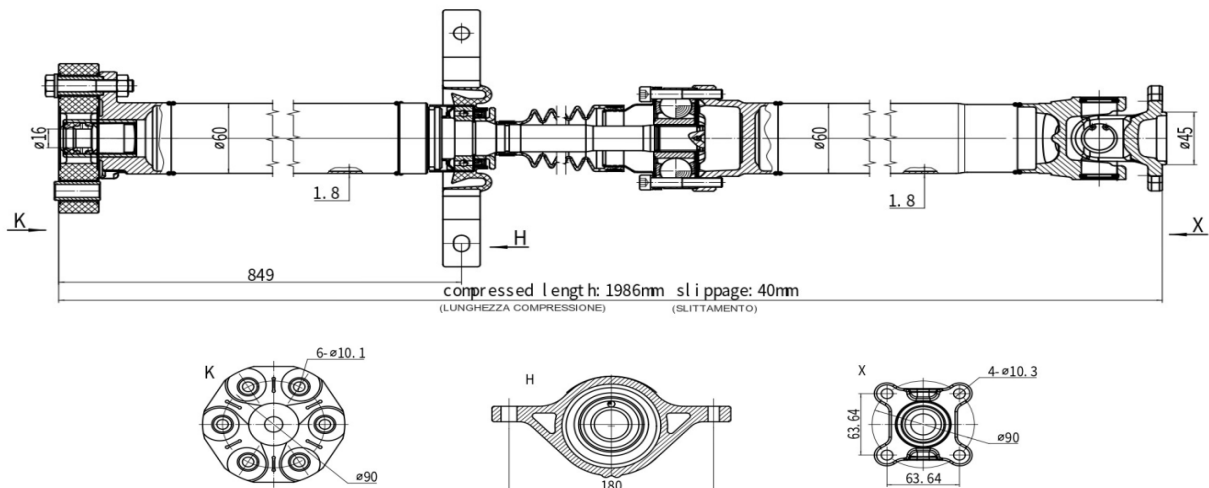

N.B.: I CODICI O.E. ED IL LORO TESTO SONO RIPORTATI SOLO A TITOLO INDICATIVO
THE O.E. CODES AND THEIR TEXT ARE REPORTED ONLY FOR INDICATIVE PURPOSE

DISEGNI TECNICI - TECHNICAL DRAWINGS

AC-0043

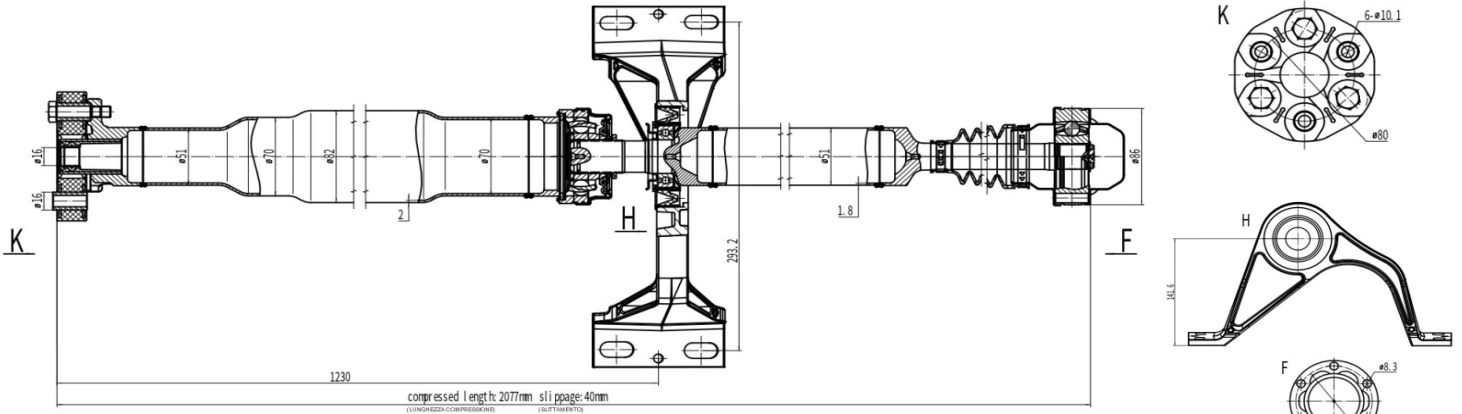

AC-0044

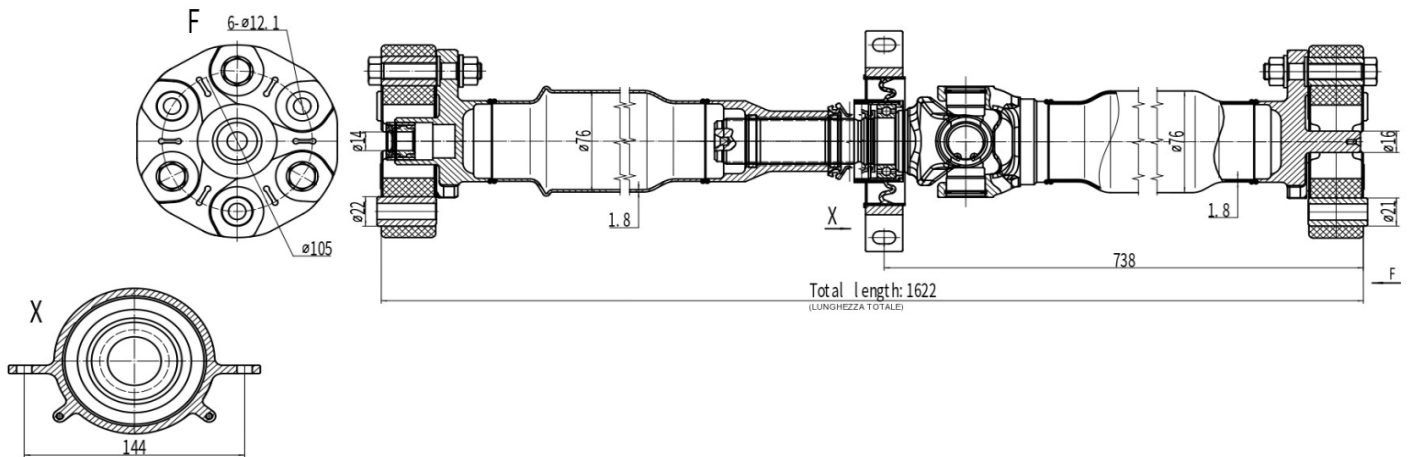

AC-0045

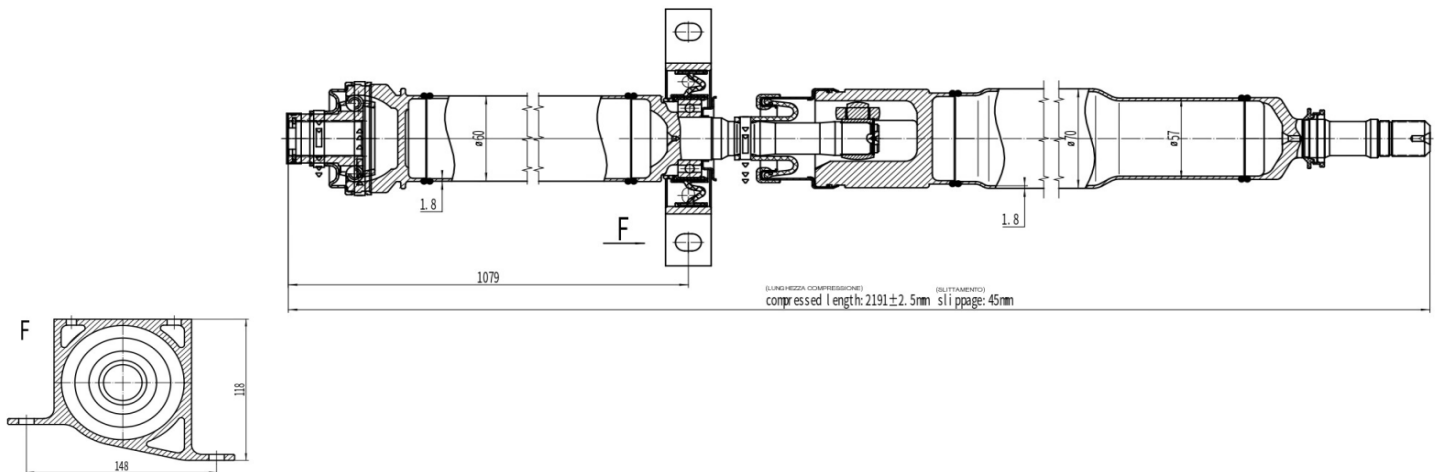

N.B.: I CODICI O.E. ED IL LORO TESTO SONO RIPORTATI SOLO A TITOLO INDICATIVO
THE O.E. CODES AND THEIR TEXT ARE REPORTED ONLY FOR INDICATIVE PURPOSE

DISEGNI TECNICI - TECHNICAL DRAWINGS

AC-0046

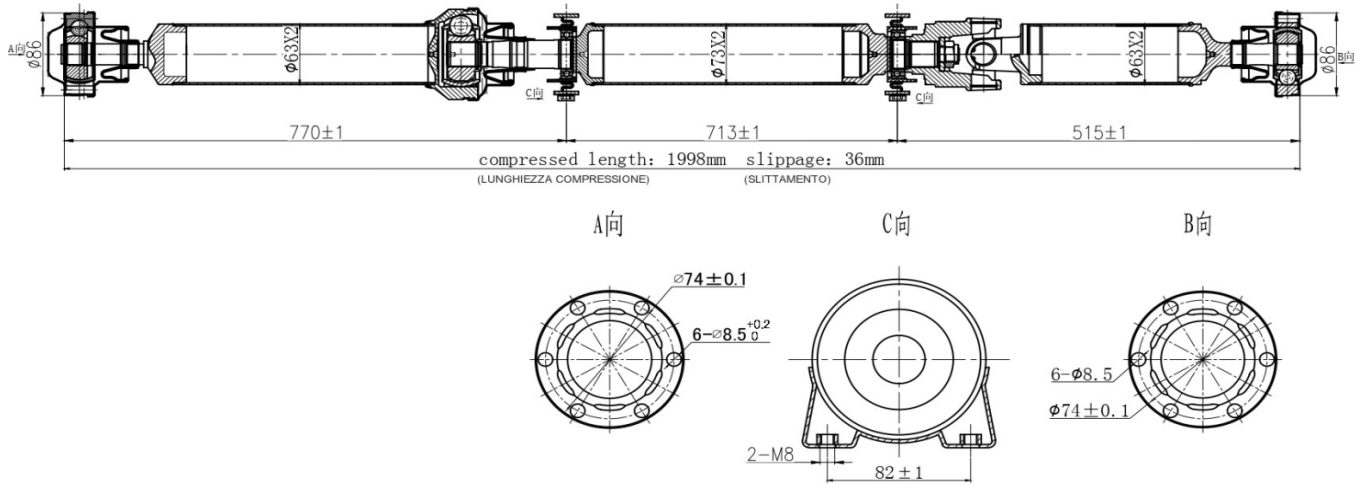

AC-0047

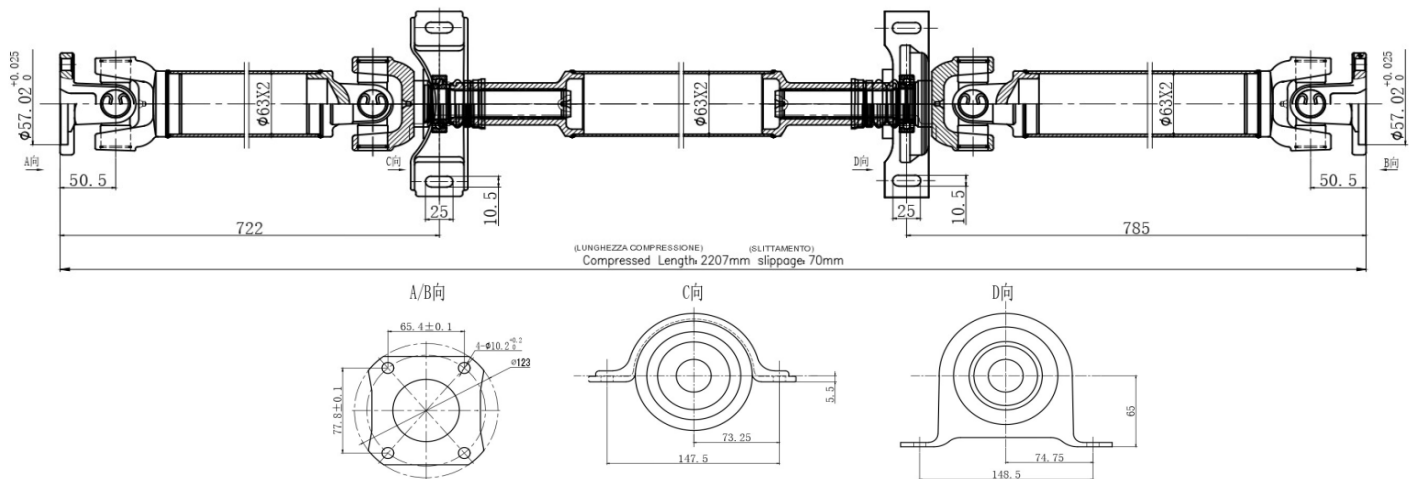

AC-0048

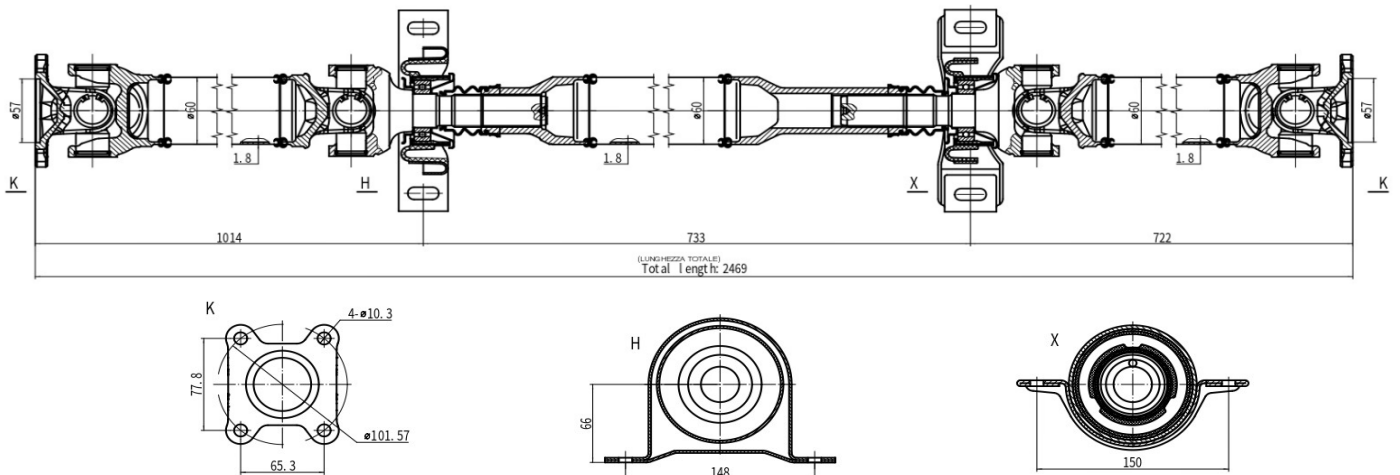

N.B.: I CODICI O.E. ED IL LORO TESTO SONO RIPORTATI SOLO A TITOLO INDICATIVO
 THE O.E. CODES AND THEIR TEXT ARE REPORTED ONLY FOR INDICATIVE PURPOSE

DISEGNI TECNICI - TECHNICAL DRAWINGS

AC-0049

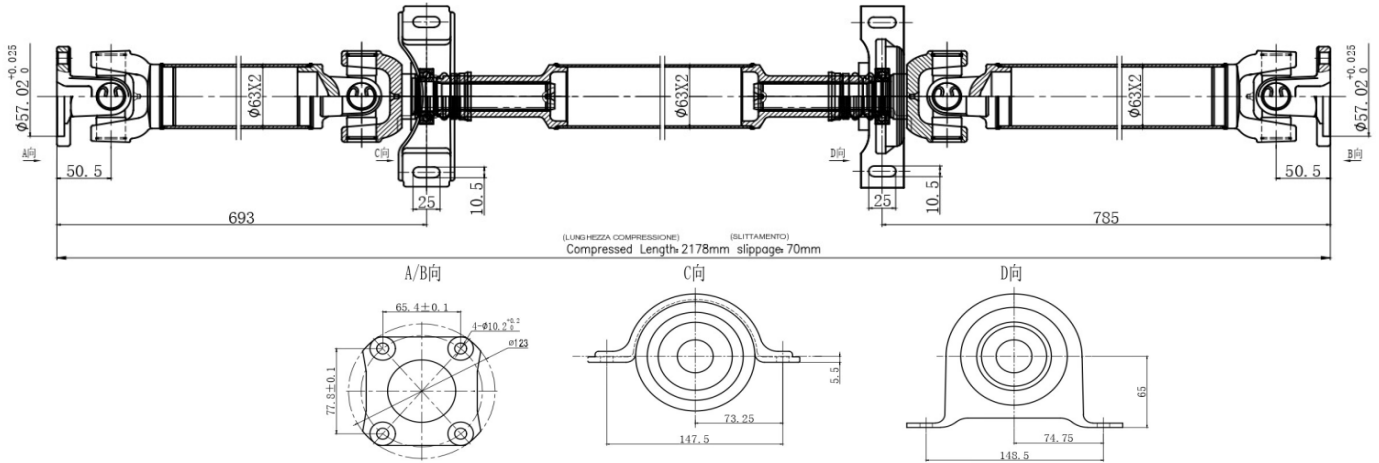

AC-0050

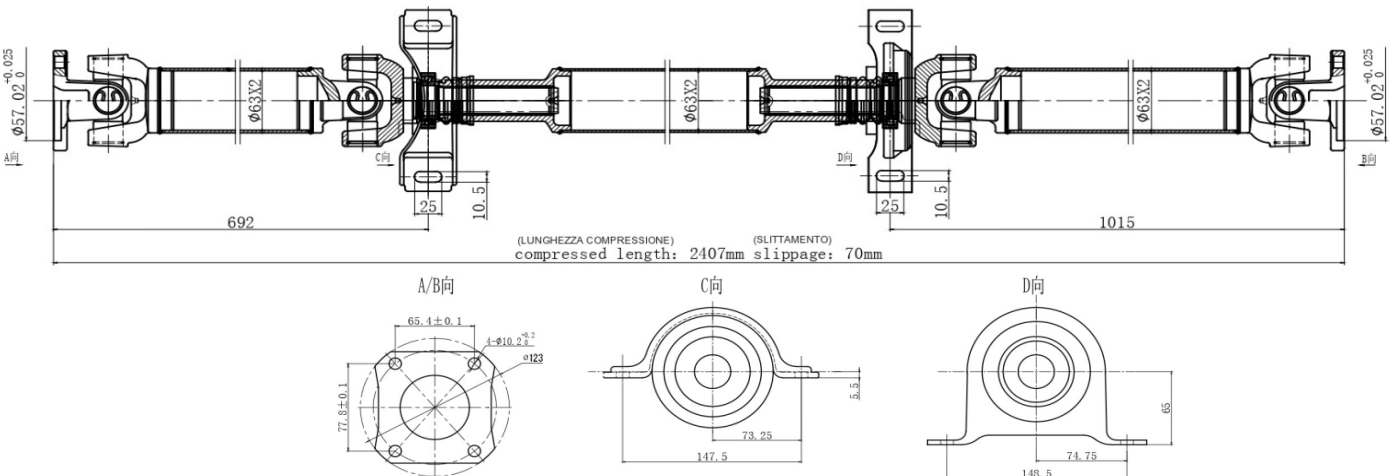

AC-0051

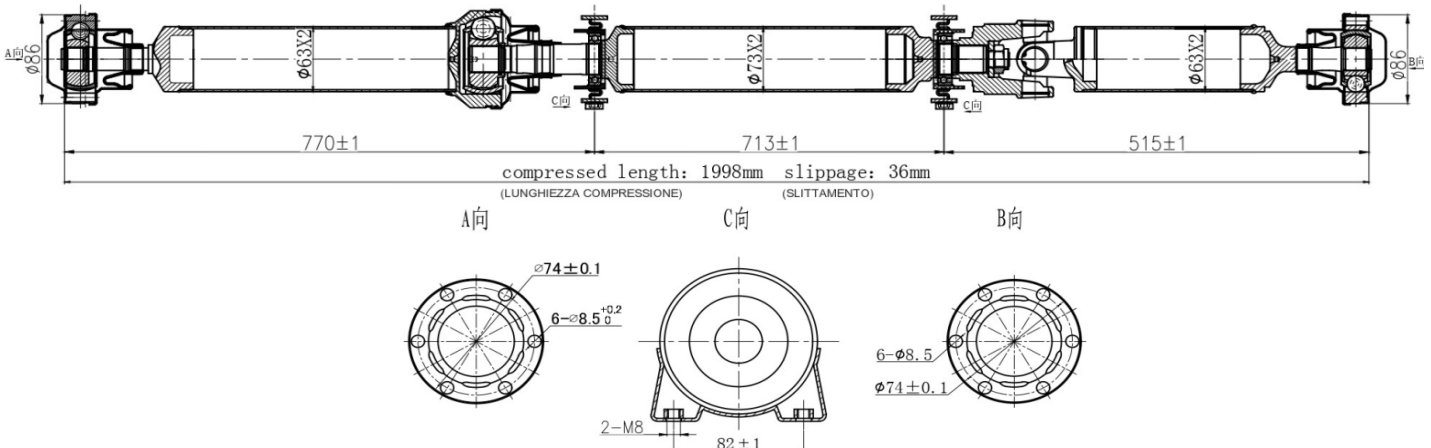

N.B.: I CODICI O.E. ED IL LORO TESTO SONO RIPORTATI SOLO A TITOLO INDICATIVO
 THE O.E. CODES AND THEIR TEXT ARE REPORTED ONLY FOR INDICATIVE PURPOSE

DISEGNI TECNICI - TECHNICAL DRAWINGS

AC-0052

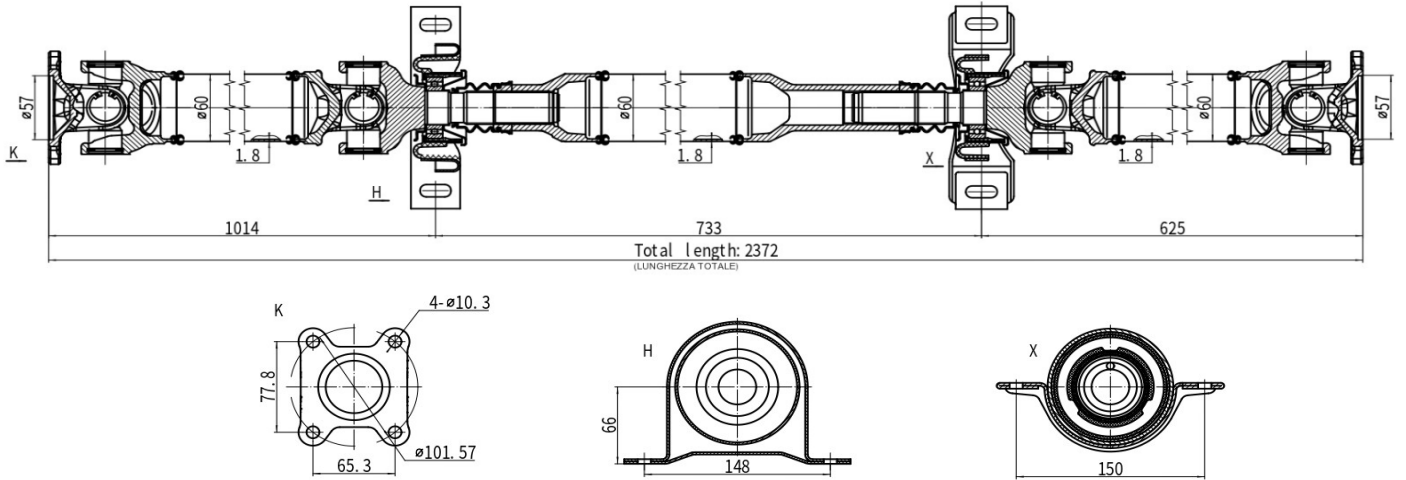

AC-0053

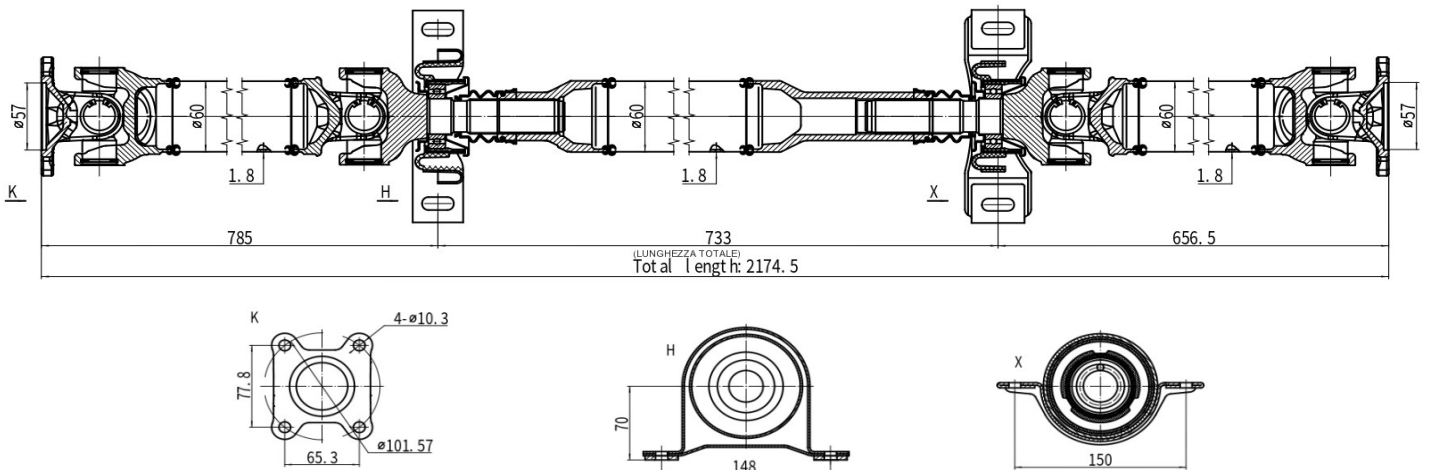

AC-0054

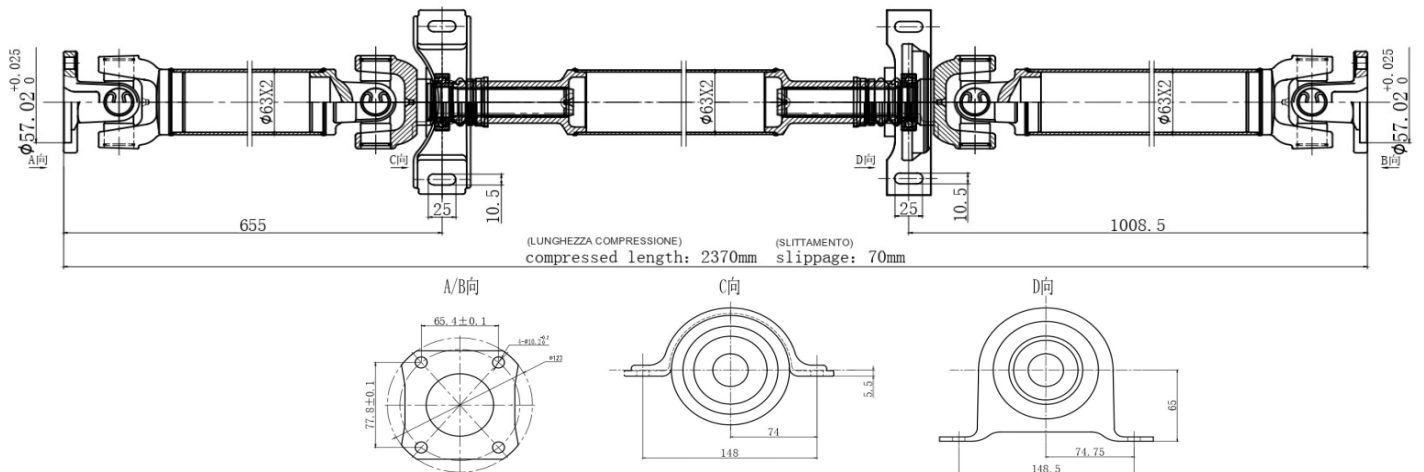

N.B.: I CODICI O.E. ED IL LORO TESTO SONO RIPORTATI SOLO A TITOLO INDICATIVO
 THE O.E. CODES AND THEIR TEXT ARE REPORTED ONLY FOR INDICATIVE PURPOSE

DISEGNI TECNICI - TECHNICAL DRAWINGS

AC-0055

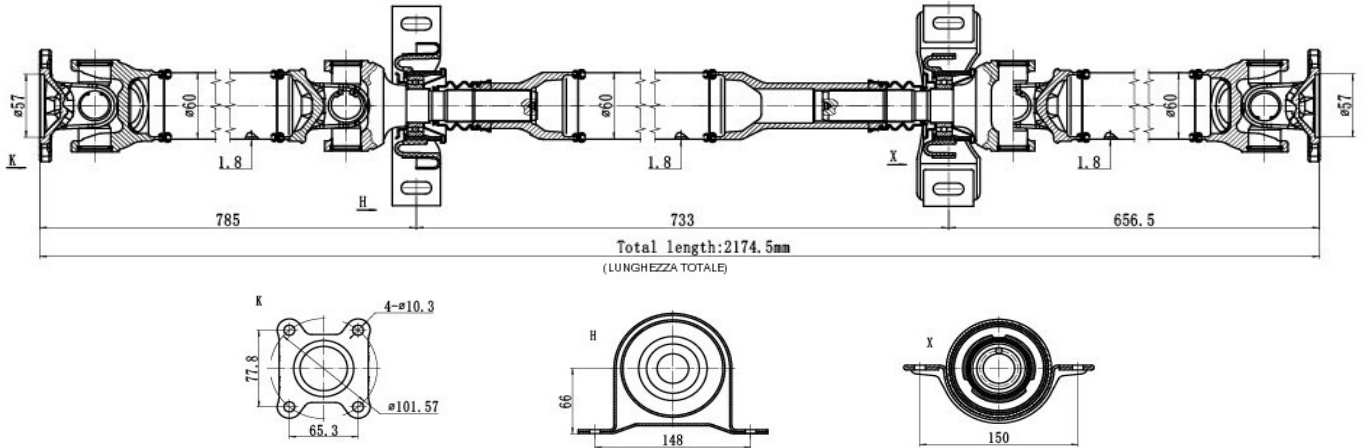

AC-0056

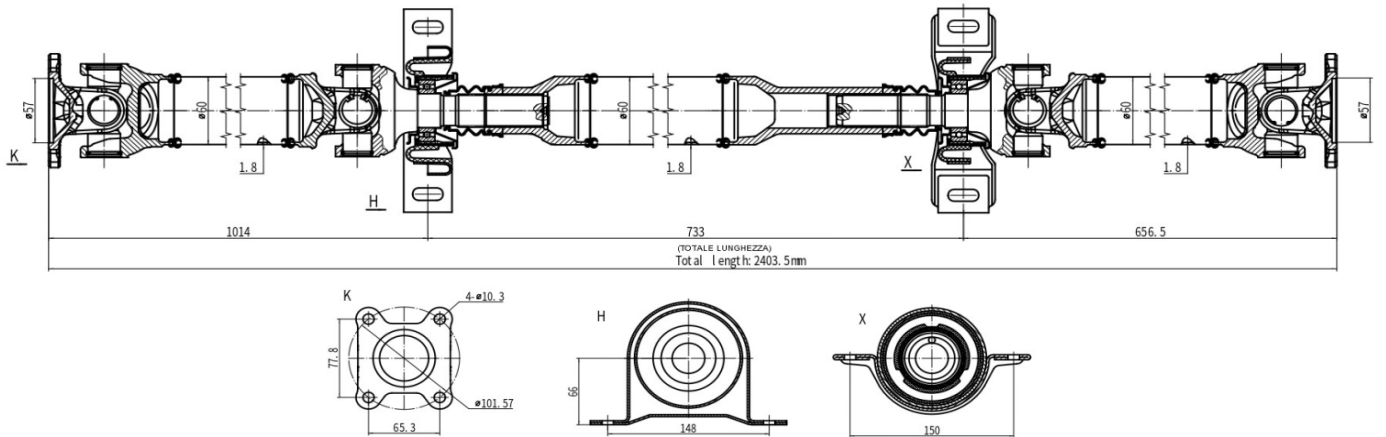

AC-0057

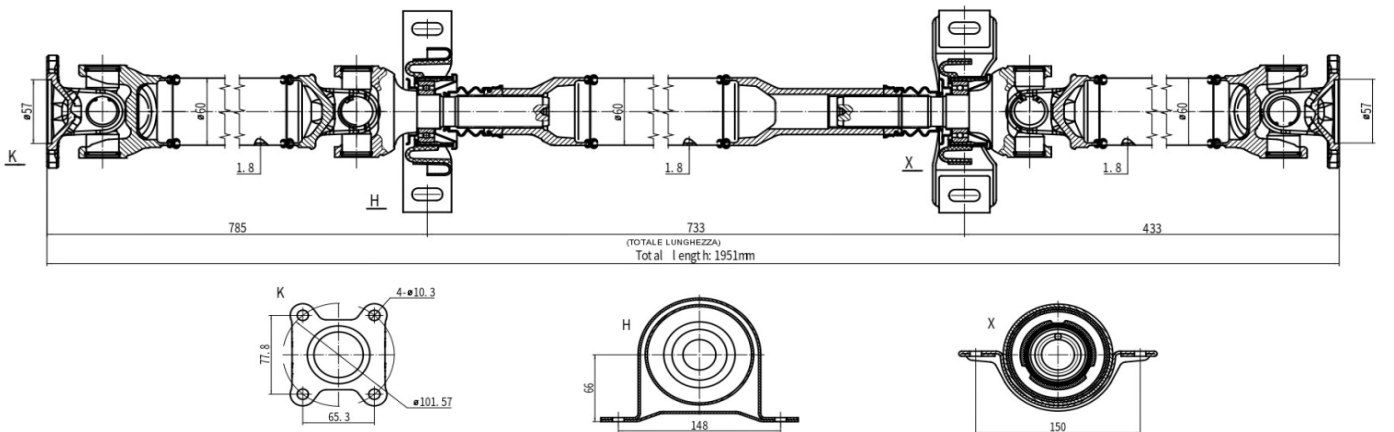

N.B.: I CODICI O.E. ED IL LORO TESTO SONO RIPOSTATI SOLO A TITOLO INDICATIVO
 THE O.E. CODES AND THEIR TEXT ARE REPORTED ONLY FOR INDICATIVE PURPOSE

DISEGNI TECNICI - TECHNICAL DRAWINGS

AC-0058

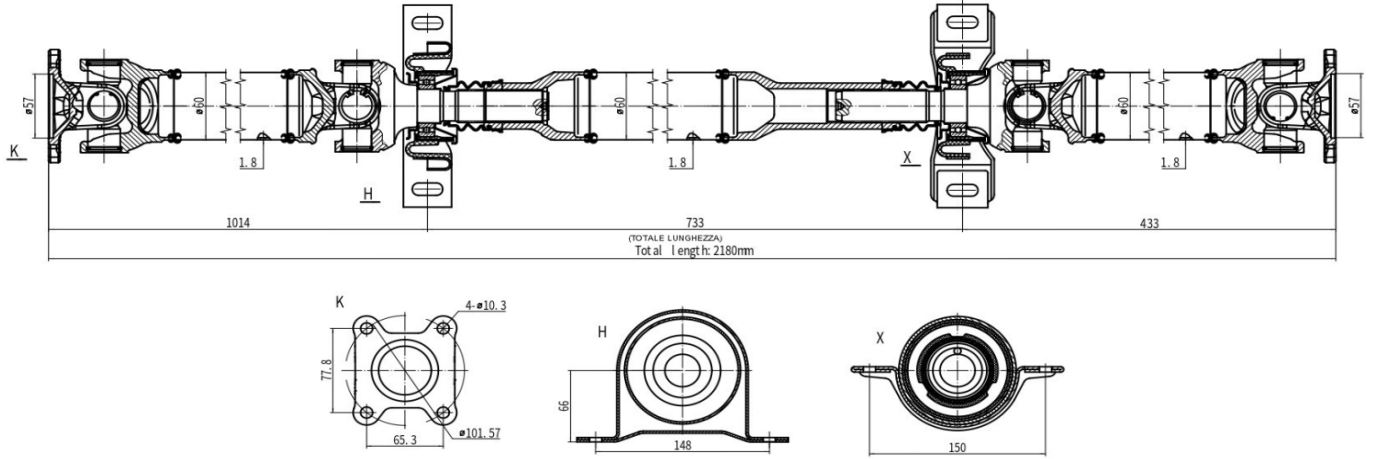

AC-0059

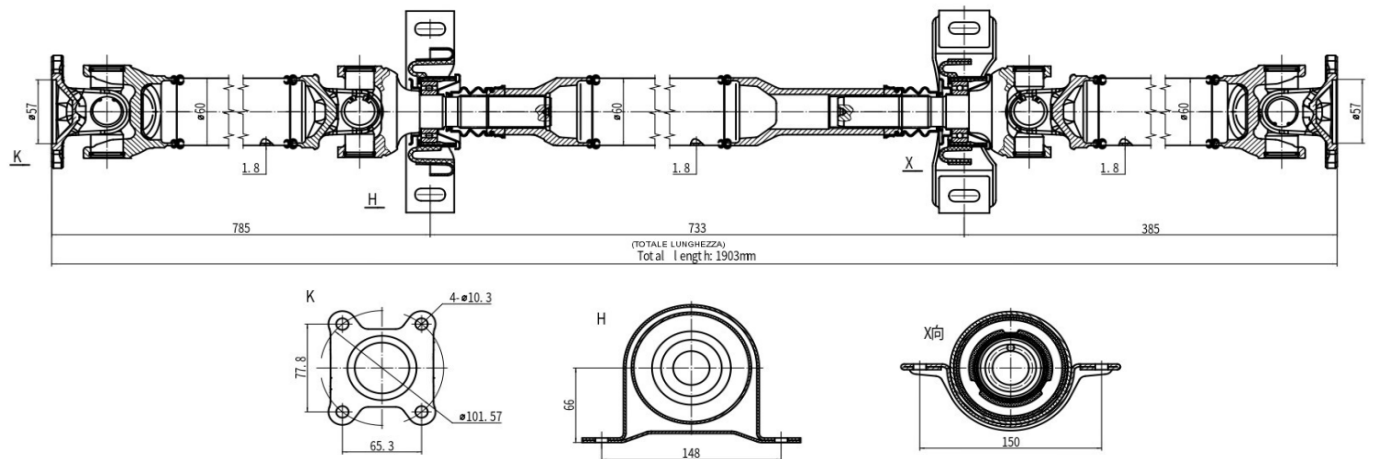

AC-0060

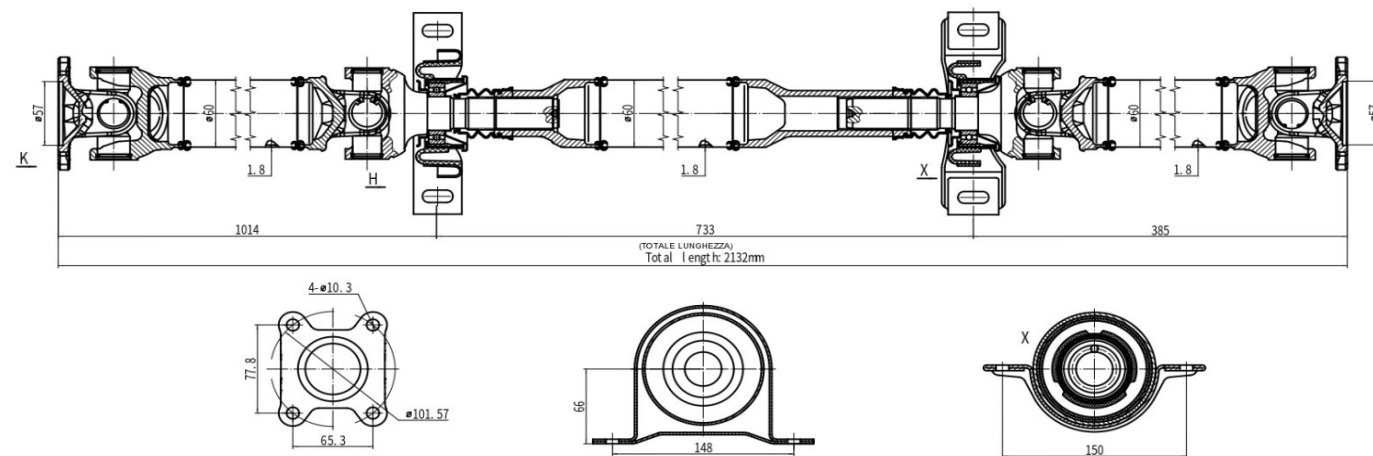

N.B.: I CODICI O.E. ED IL LORO TESTO SONO RIPORTATI SOLO A TITOLO INDICATIVO
 THE O.E. CODES AND THEIR TEXT ARE REPORTED ONLY FOR INDICATIVE PURPOSE

DISEGNI TECNICI - TECHNICAL DRAWINGS

AC-0061

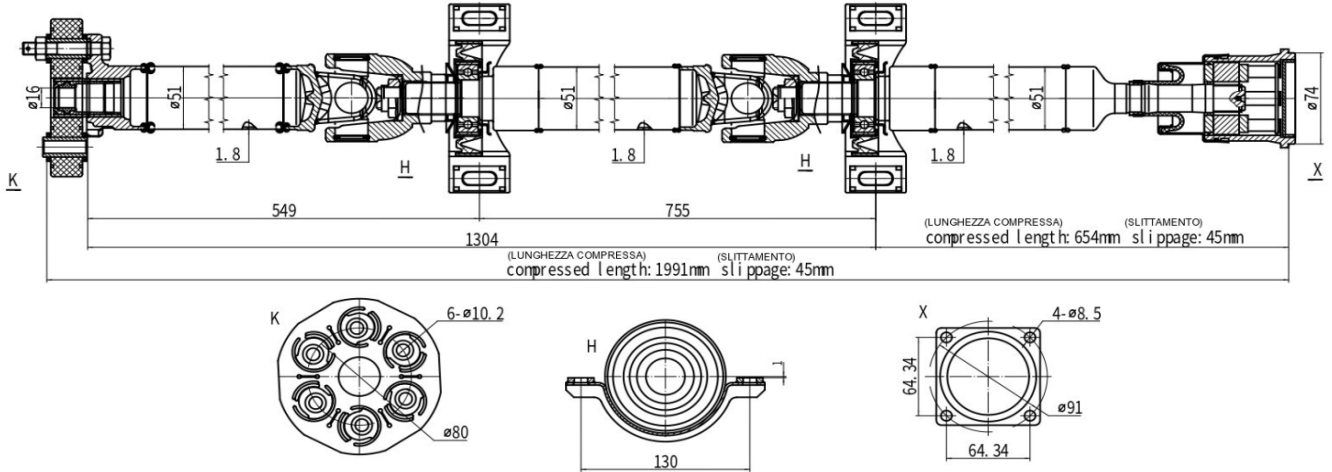

AC-0062

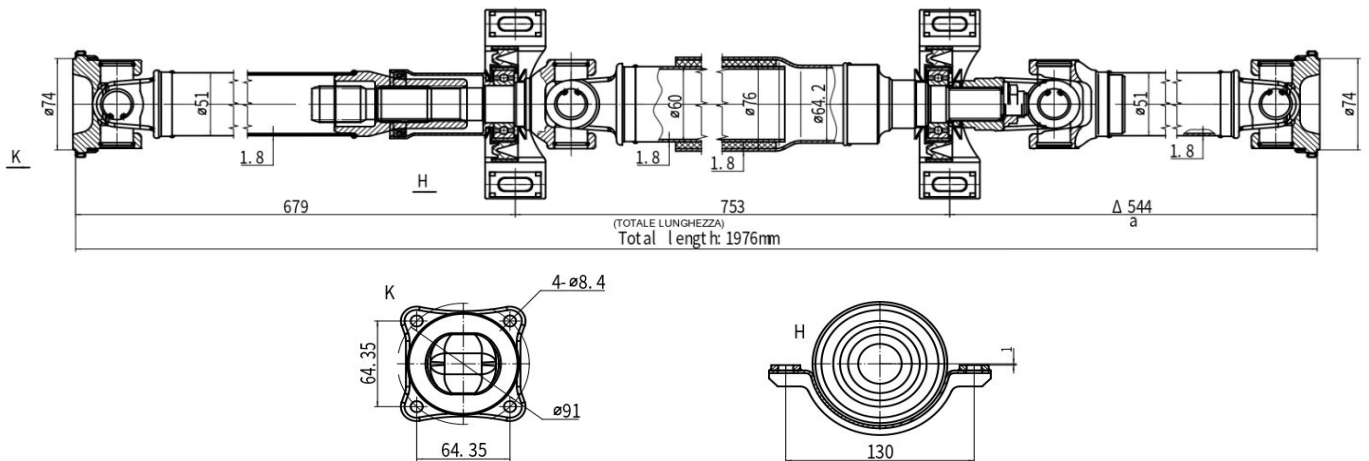

AC-0063

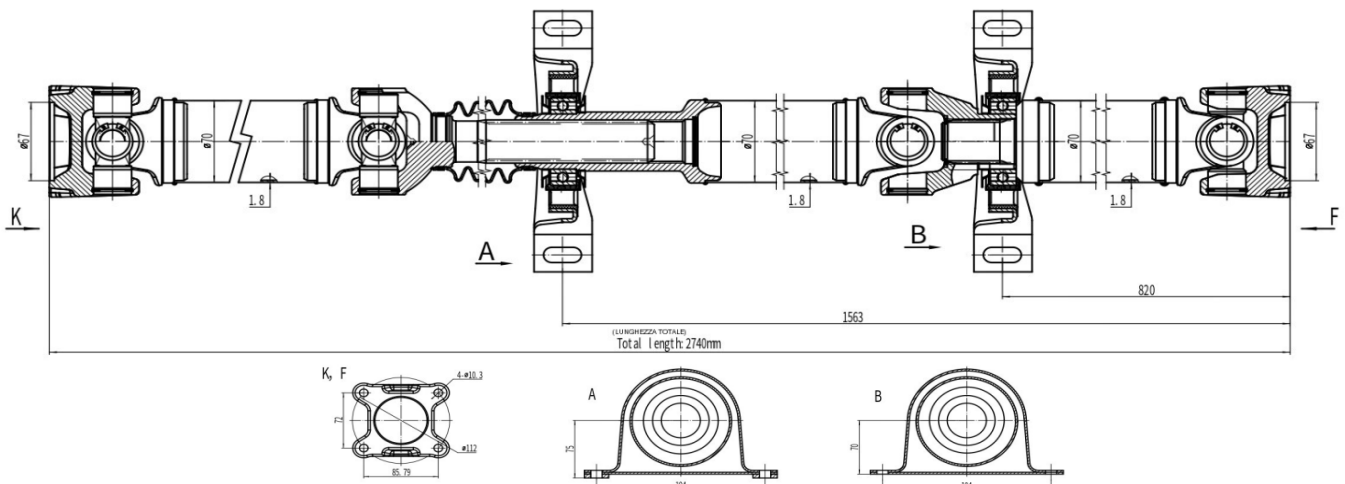

N.B.: I CODICI O.E. ED IL LORO TESTO SONO RIPOSTATI SOLO A TITOLO INDICATIVO
 THE O.E. CODES AND THEIR TEXT ARE REPORTED ONLY FOR INDICATIVE PURPOSE

DISEGNI TECNICI - TECHNICAL DRAWINGS

AC-0064

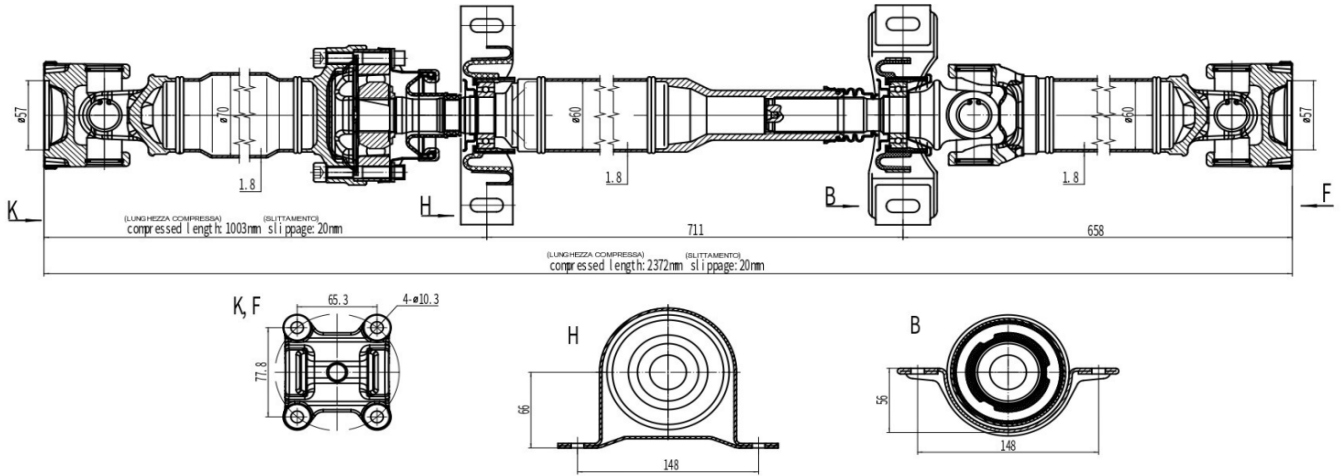

AC-0065

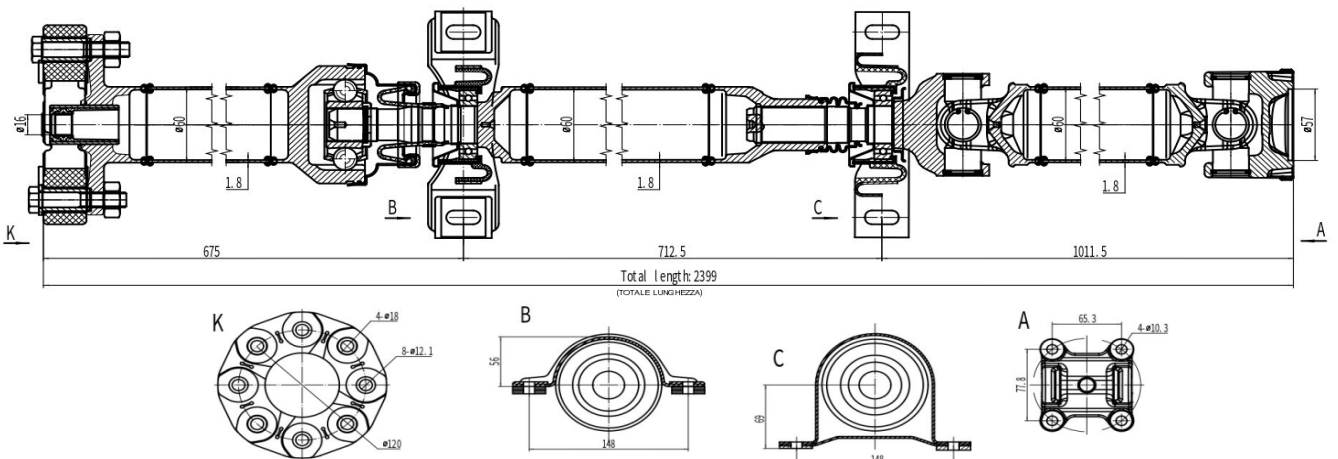

AC-0066

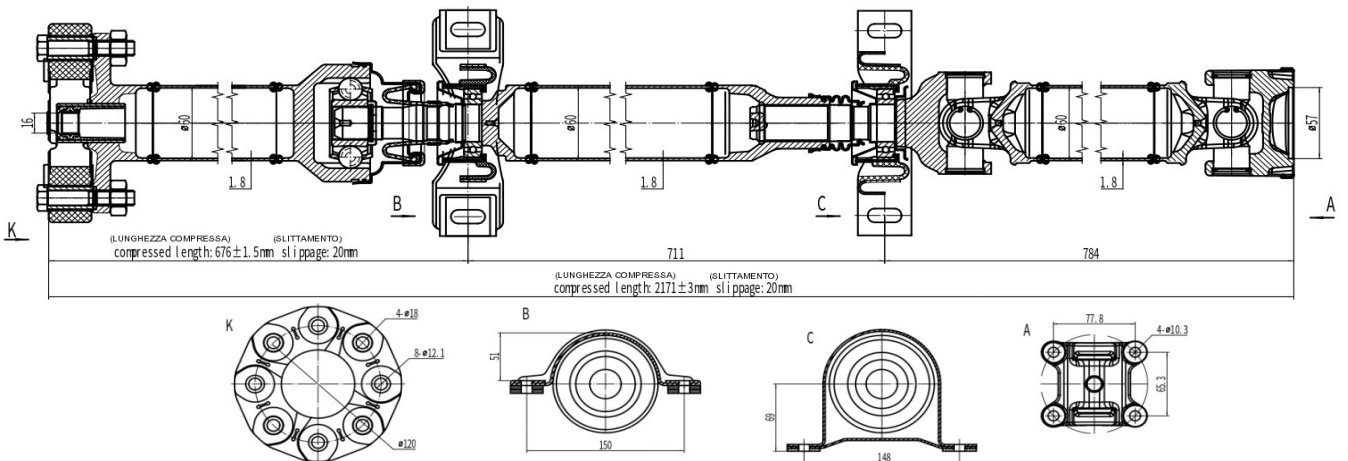

N.B.: I CODICI O.E. ED IL LORO TESTO SONO RIPORTATI SOLO A TITOLO INDICATIVO
 THE O.E. CODES AND THEIR TEXT ARE REPORTED ONLY FOR INDICATIVE PURPOSE

DISEGNI TECNICI - TECHNICAL DRAWINGS

AC-0067

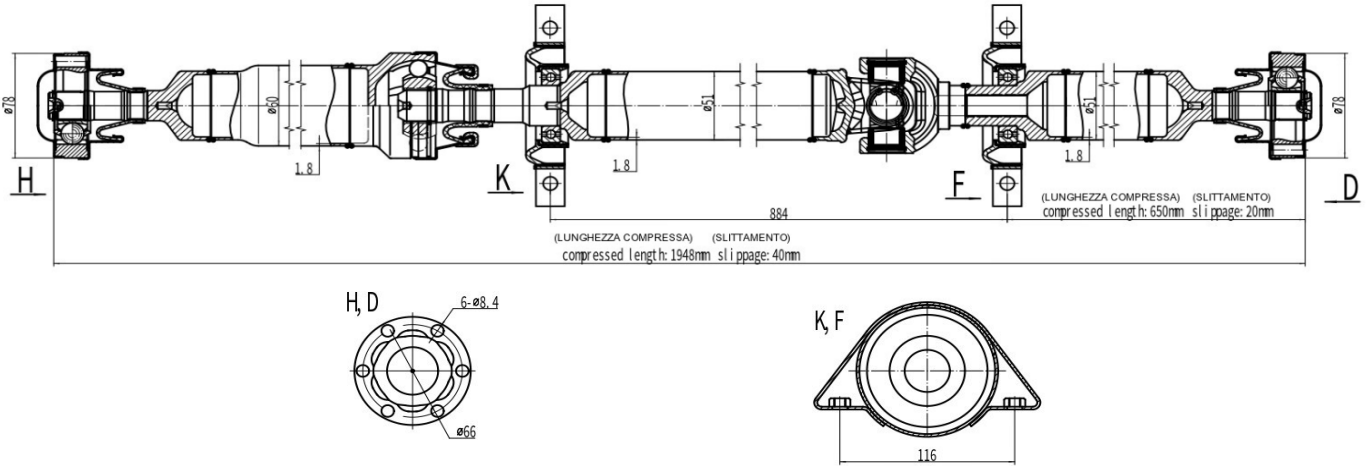

AC-0068

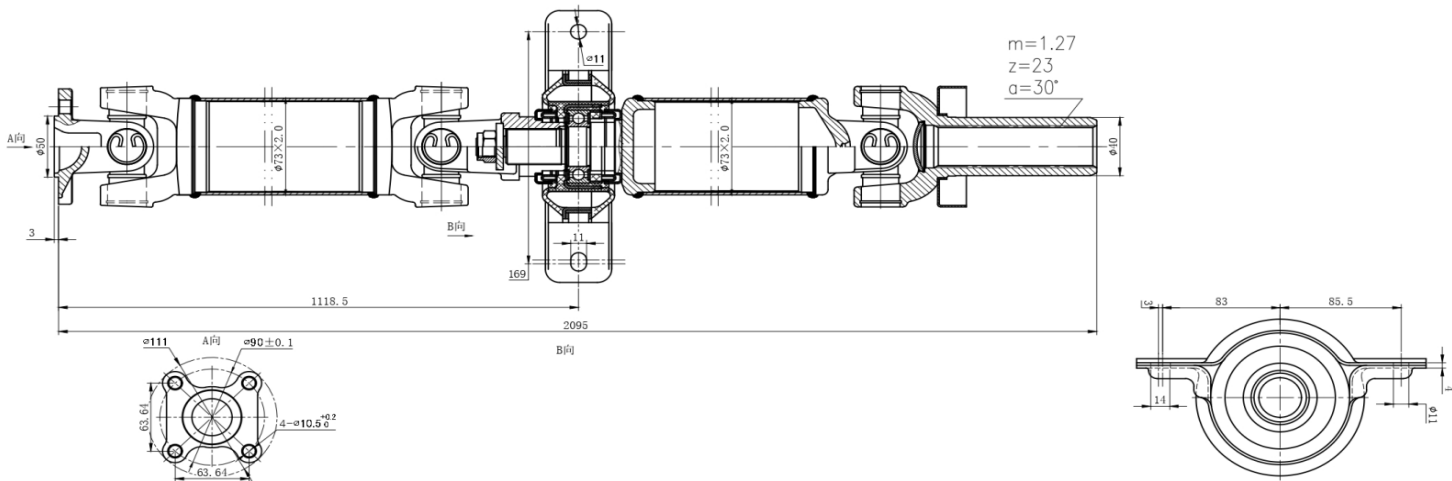

AC-0070

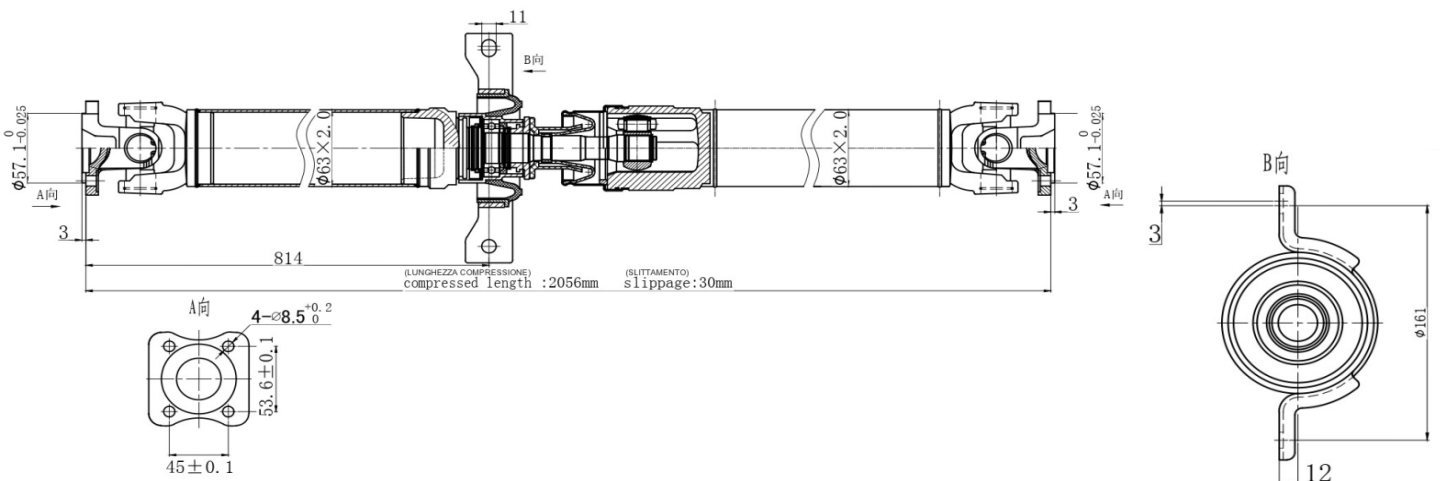

N.B.: I CODICI O.E. ED IL LORO TESTO SONO RIPORTATI SOLO A TITOLO INDICATIVO
 THE O.E. CODES AND THEIR TEXT ARE REPORTED ONLY FOR INDICATIVE PURPOSE

DISEGNI TECNICI - TECHNICAL DRAWINGS

AC-0071

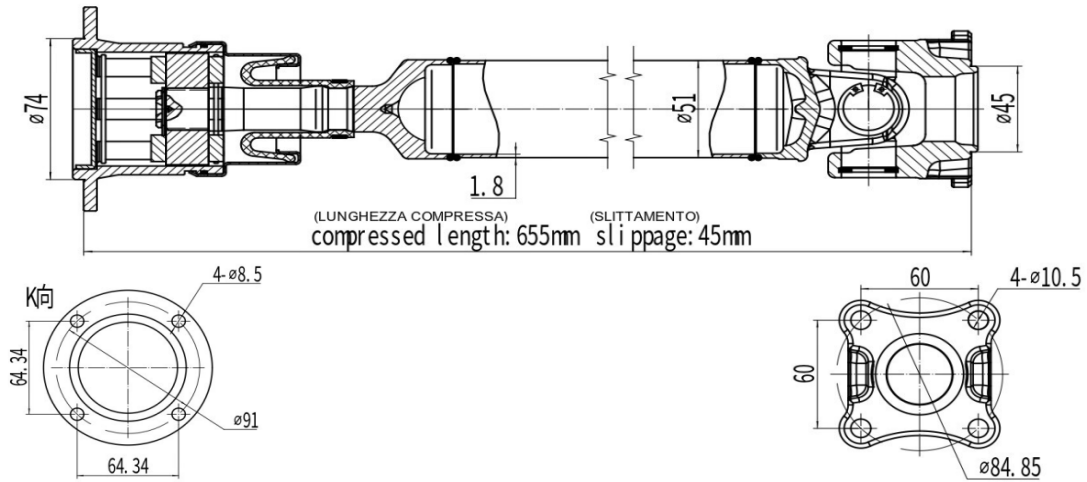

AC-0072

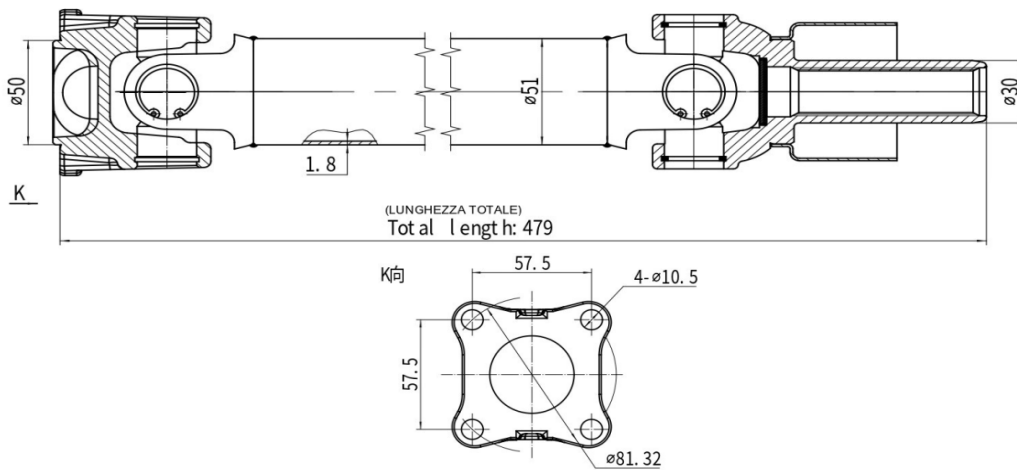

AC-0073

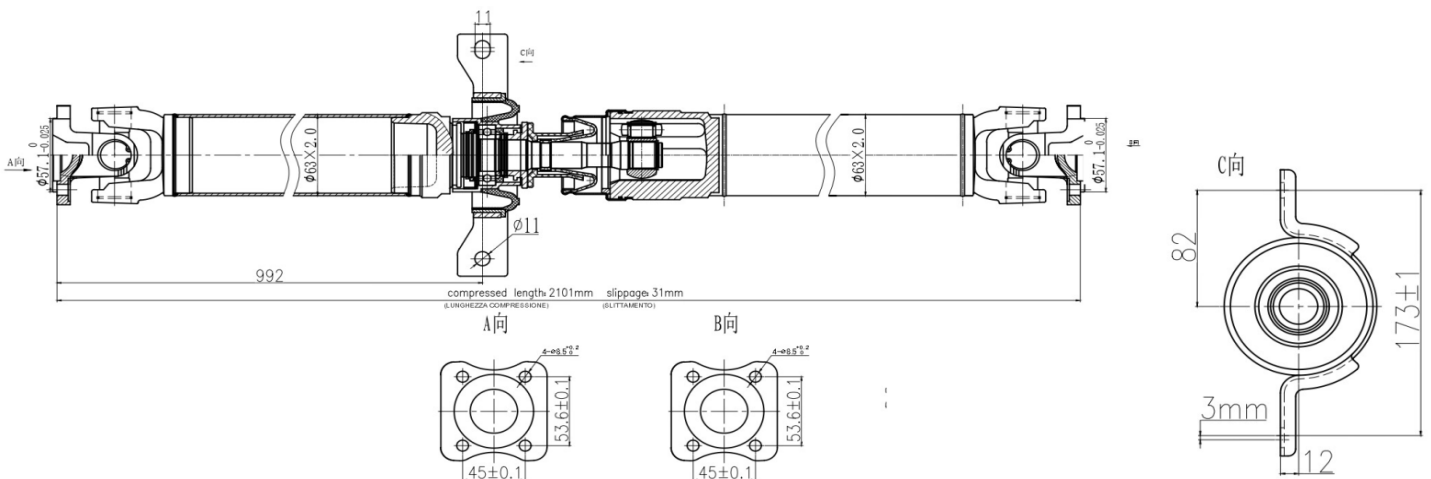

N.B.: I CODICI O.E. ED IL LORO TESTO SONO RIPORTATI SOLO A TITOLO INDICATIVO
 THE O.E. CODES AND THEIR TEXT ARE REPORTED ONLY FOR INDICATIVE PURPOSE

DISEGNI TECNICI - TECHNICAL DRAWINGS

AC-0074

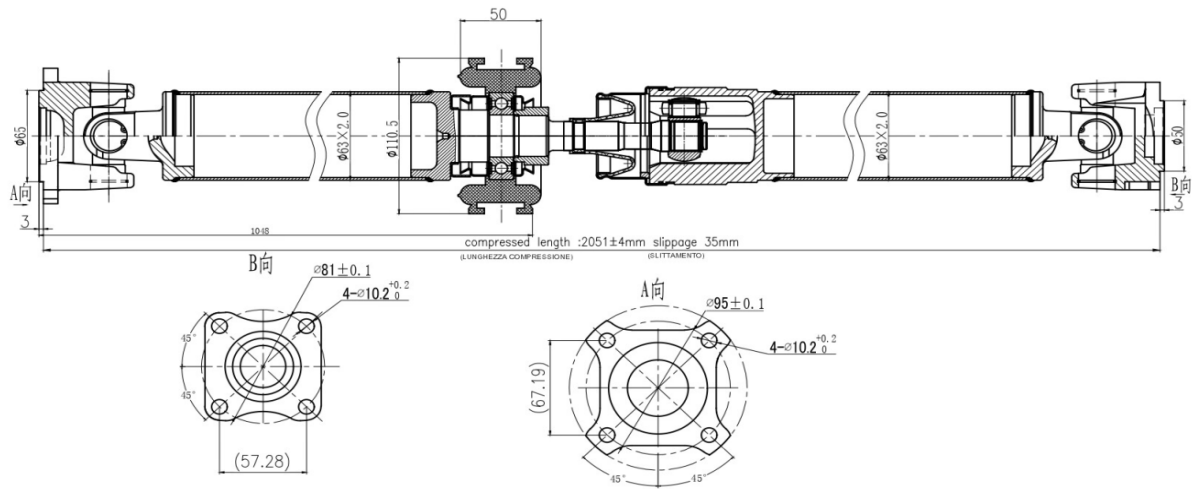

AC-0075

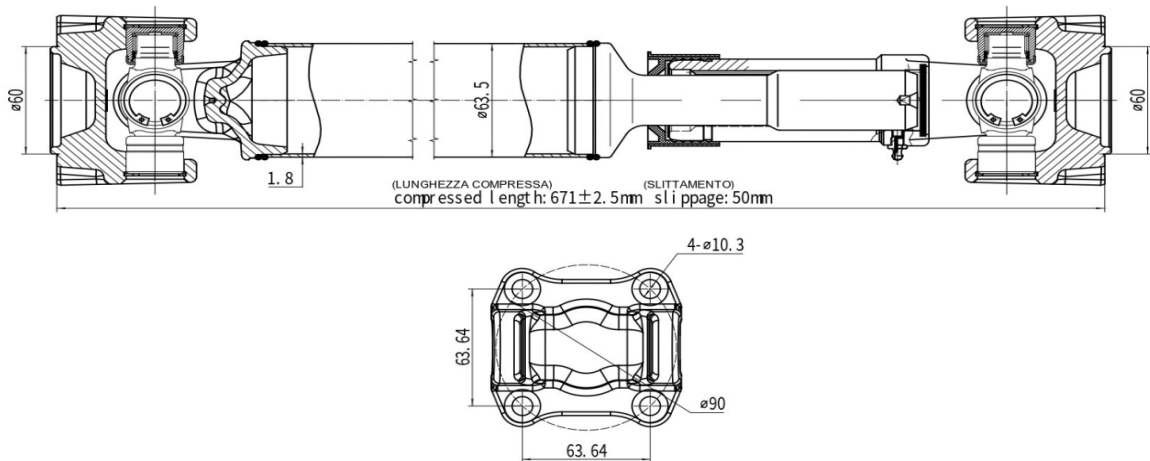

AC-0076

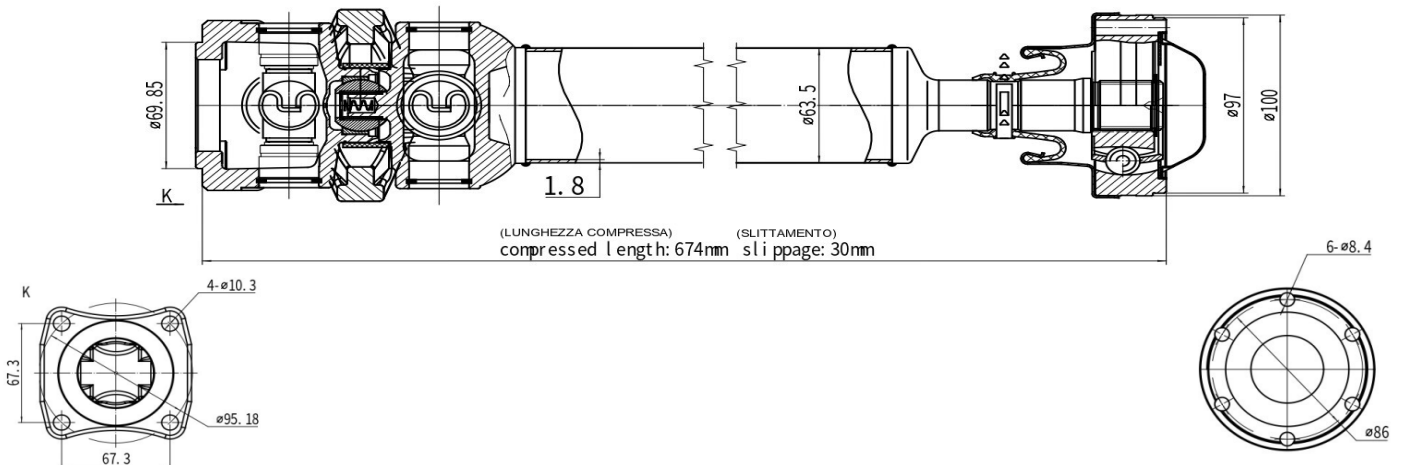

N.B.: I CODICI O.E. ED IL LORO TESTO SONO RIPORTATI SOLO A TITOLO INDICATIVO
 THE O.E. CODES AND THEIR TEXT ARE REPORTED ONLY FOR INDICATIVE PURPOSE

DISEGNI TECNICI - TECHNICAL DRAWINGS

AC-0077

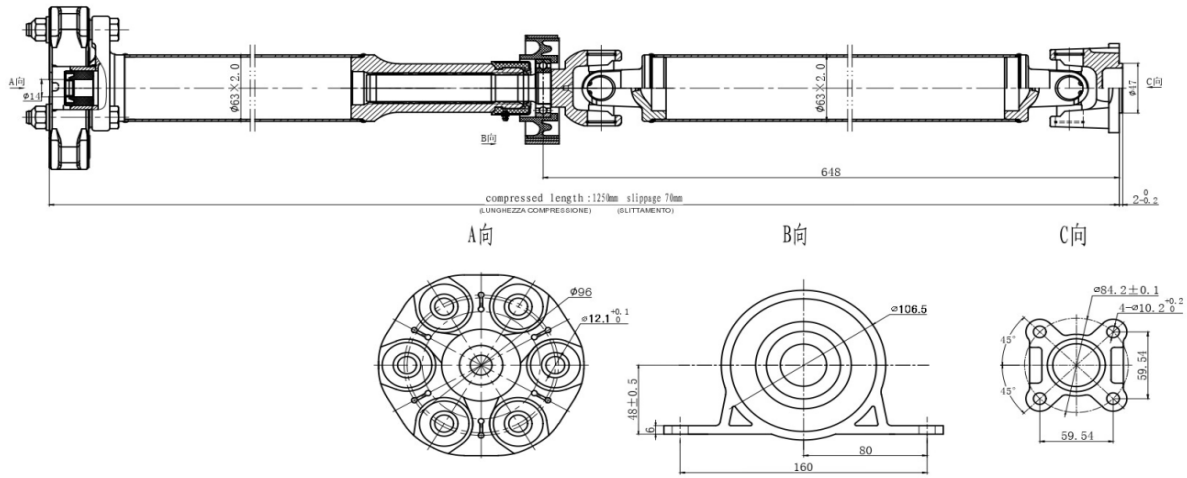

AC-0078

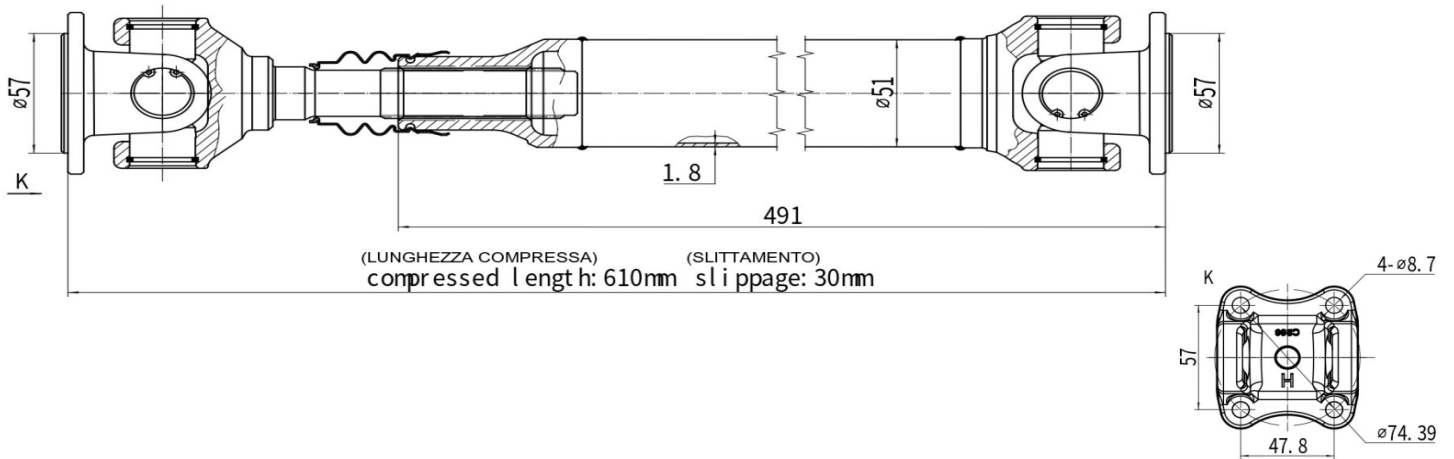

AC-0079

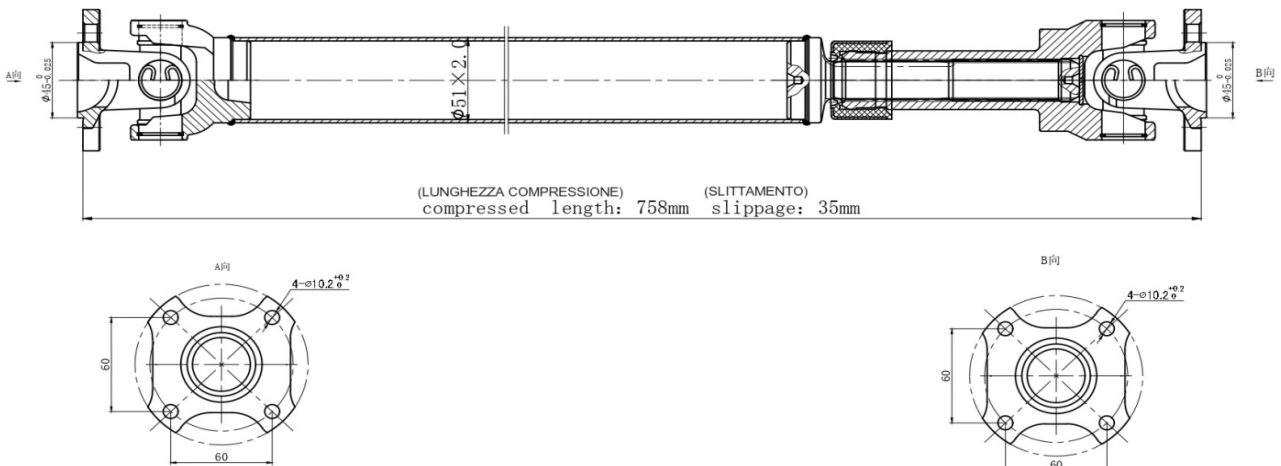

N.B.: I CODICI O.E. ED IL LORO TESTO SONO RIPORTATI SOLO A TITOLO INDICATIVO
 THE O.E. CODES AND THEIR TEXT ARE REPORTED ONLY FOR INDICATIVE PURPOSE

DISEGNI TECNICI - TECHNICAL DRAWINGS

AC-0080

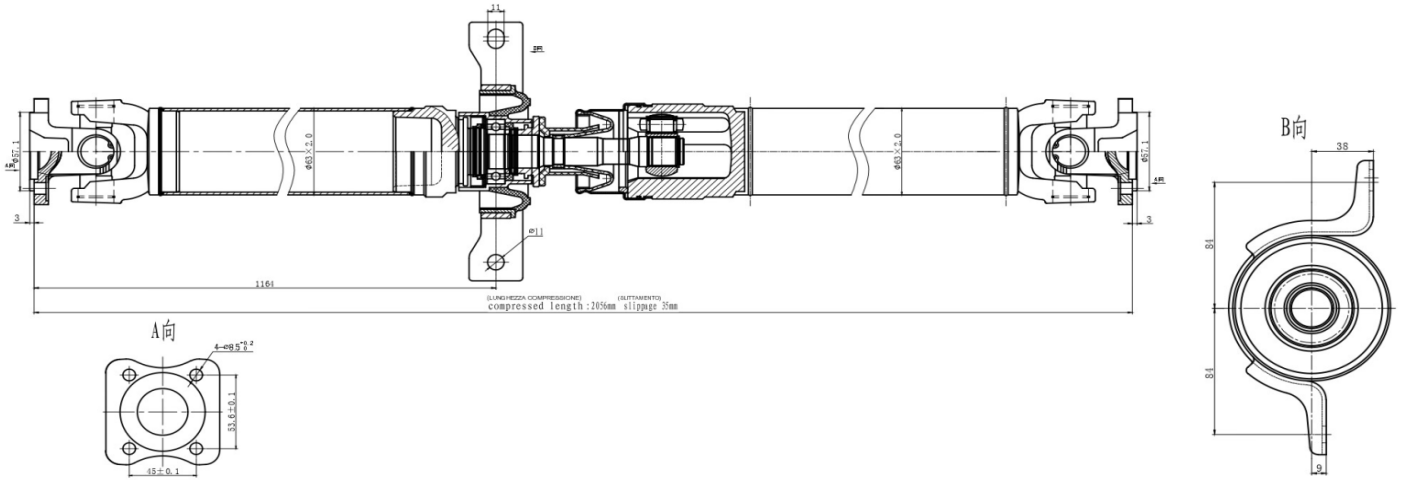

AC-0081

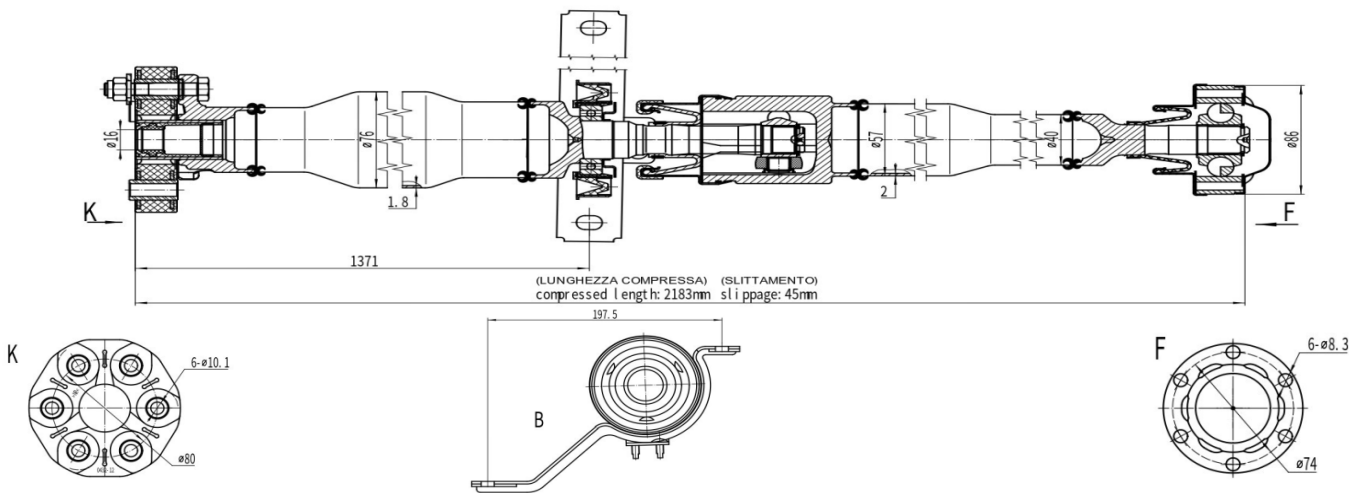

AC-0082

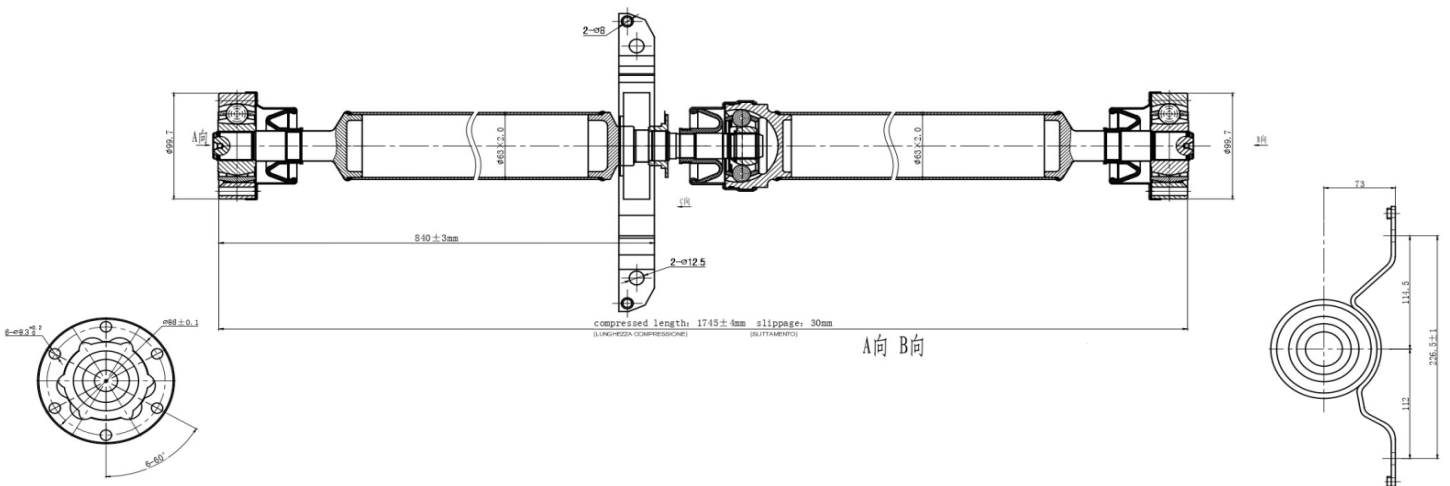

N.B.: I CODICI O.E. ED IL LORO TESTO SONO RIPIRTATI SOLO A TITOLO INDICATIVO
THE O.E. CODES AND THEIR TEXT ARE REPORTED ONLY FOR INDICATIVE PURPOSE

DISEGNI TECNICI - TECHNICAL DRAWINGS

AC-0083

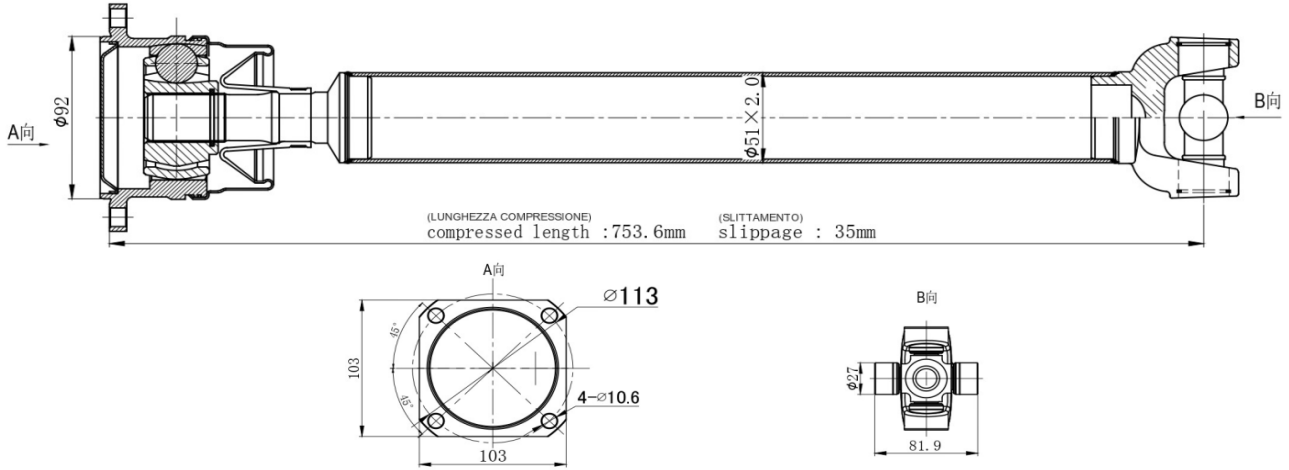

AC-0085

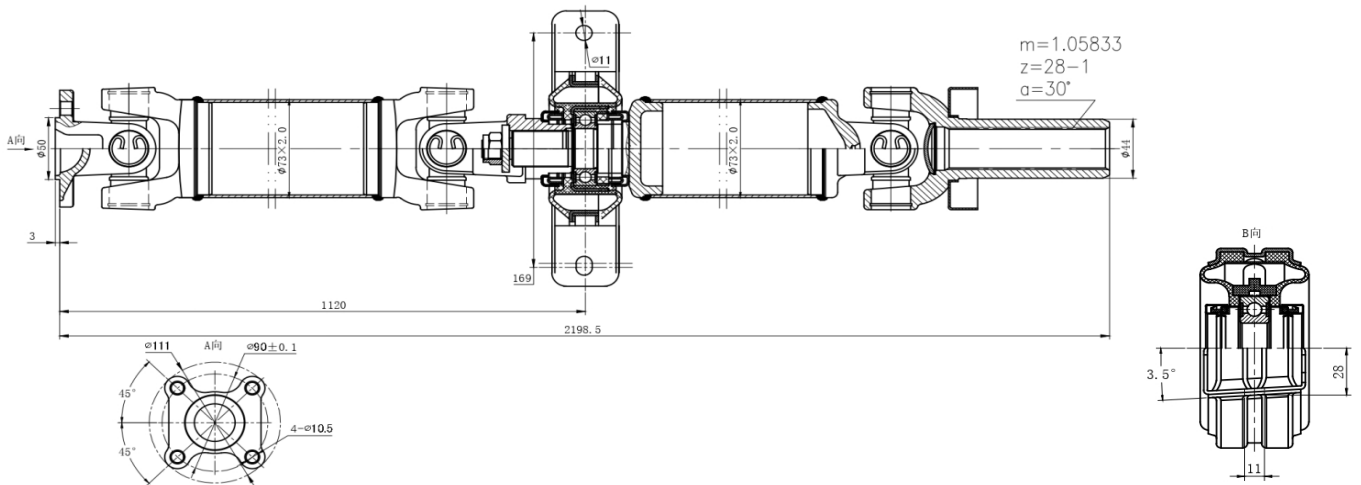

AC-0086

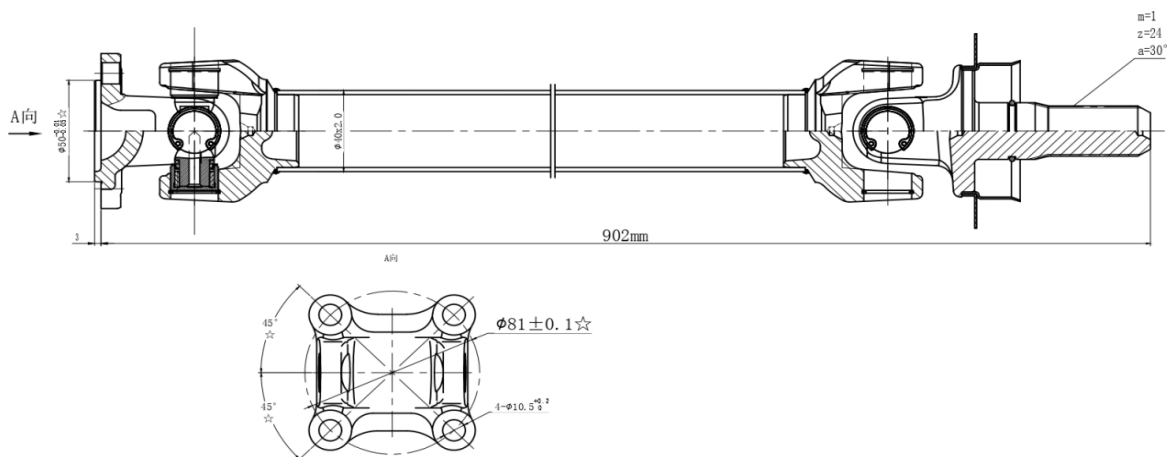

N.B.: I CODICI O.E. ED IL LORO TESTO SONO RIPOSTATI SOLO A TITOLO INDICATIVO
THE O.E. CODES AND THEIR TEXT ARE REPORTED ONLY FOR INDICATIVE PURPOSE

DISEGNI TECNICI - TECHNICAL DRAWINGS

AC-0087

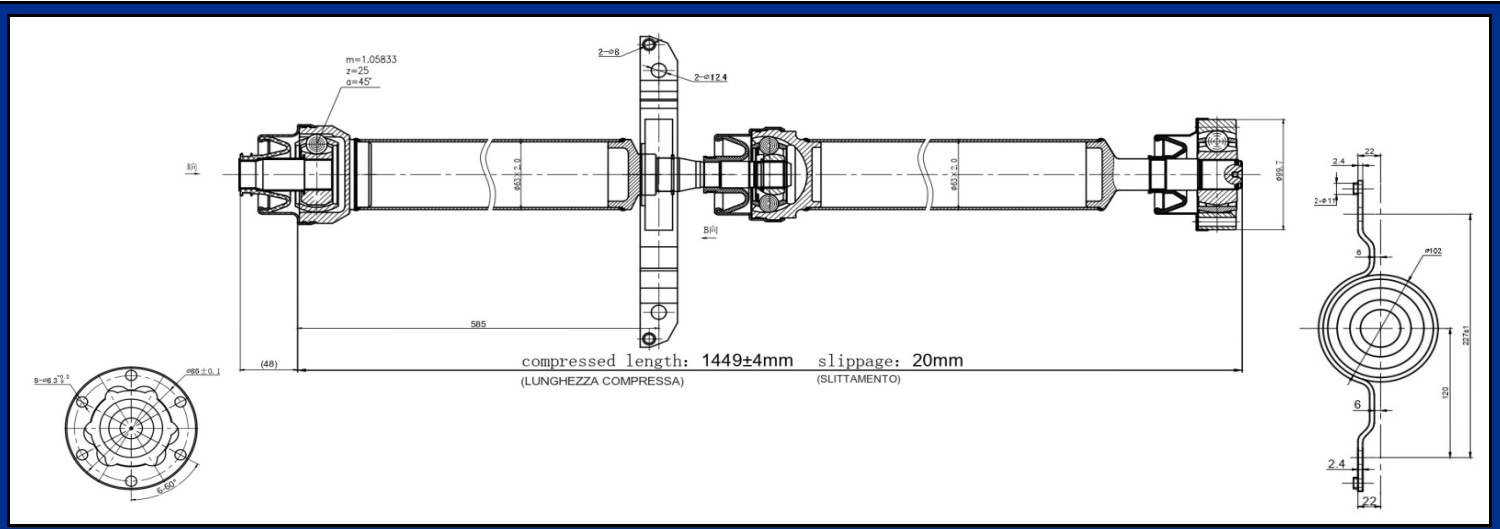

AC-0088

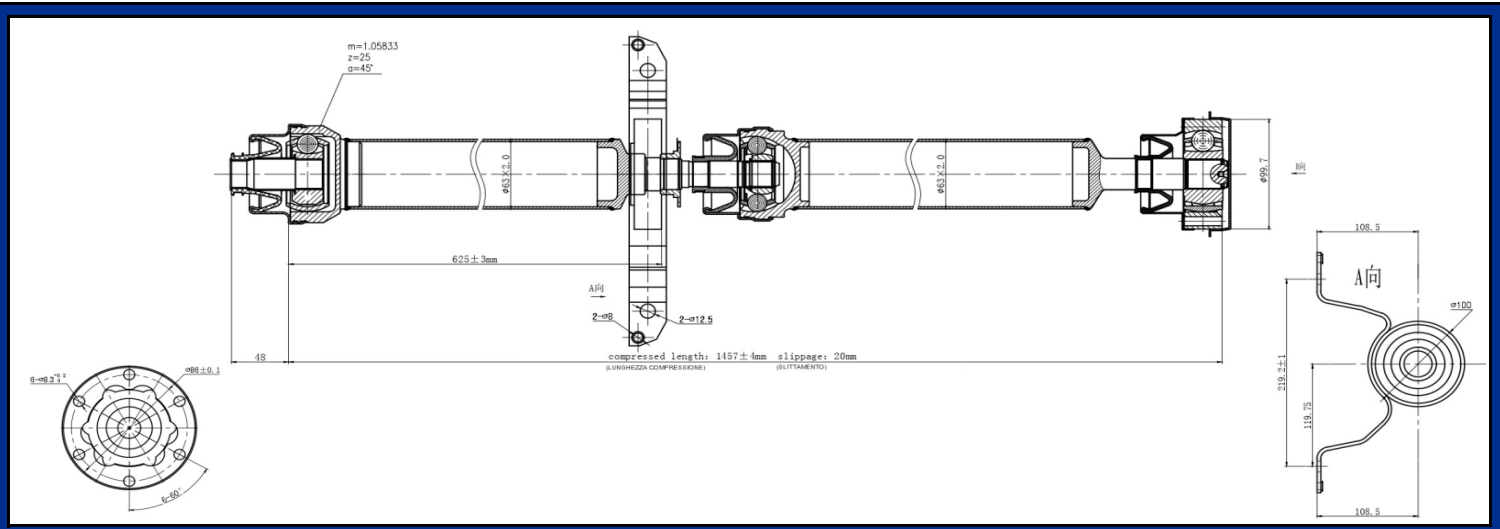

AC-0089

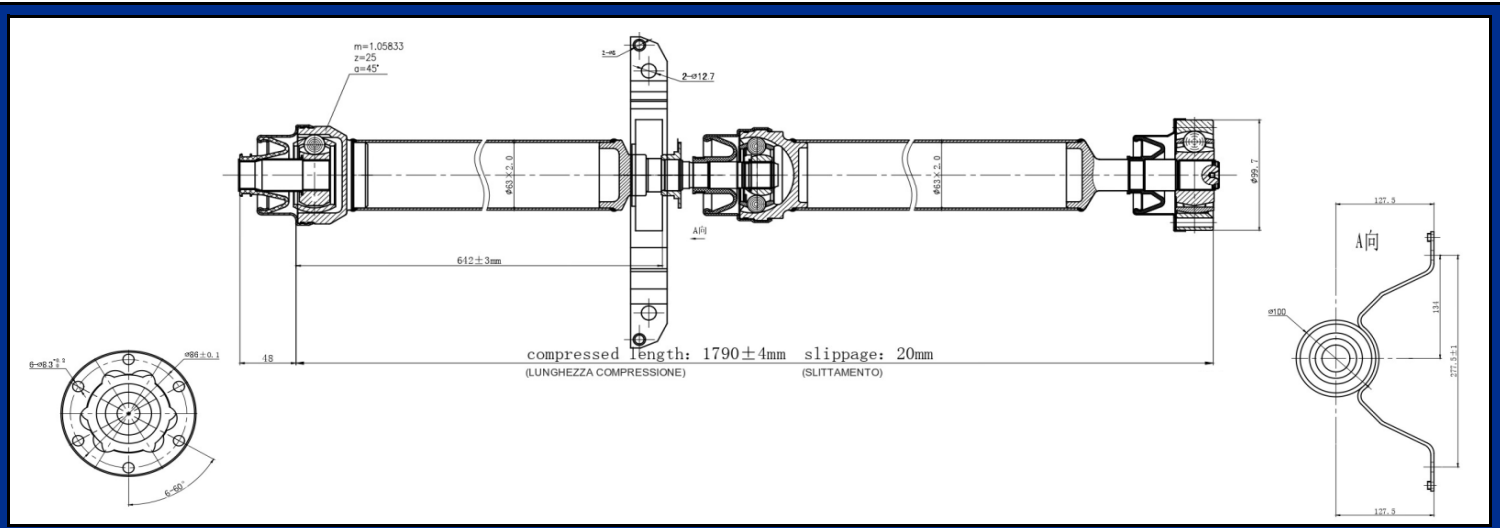

N.B.: I CODICI O.E. ED IL LORO TESTO SONO RIPORTATI SOLO A TITOLO INDICATIVO
 THE O.E. CODES AND THEIR TEXT ARE REPORTED ONLY FOR INDICATIVE PURPOSE

DISEGNI TECNICI - TECHNICAL DRAWINGS

AC-0090

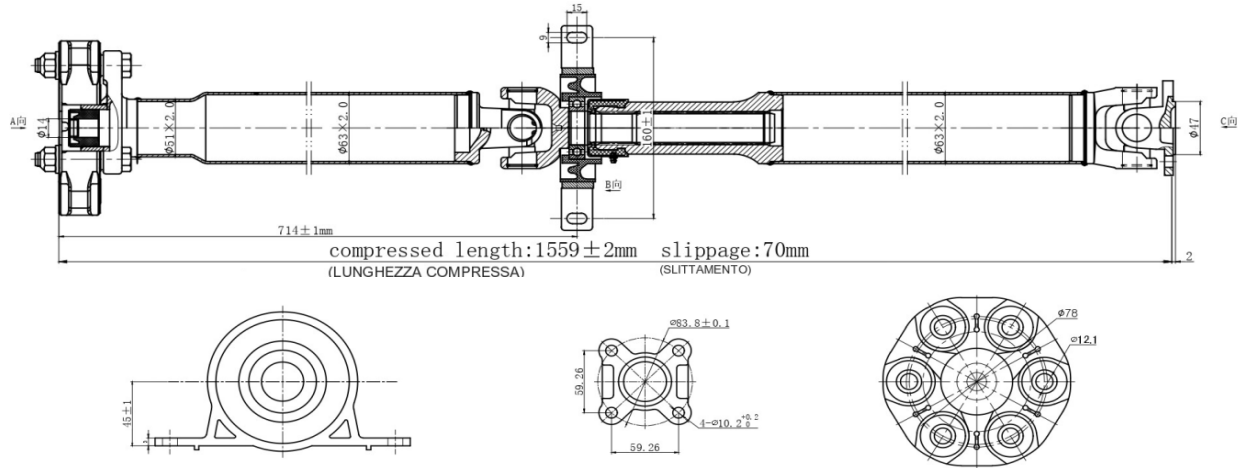

AC-0091

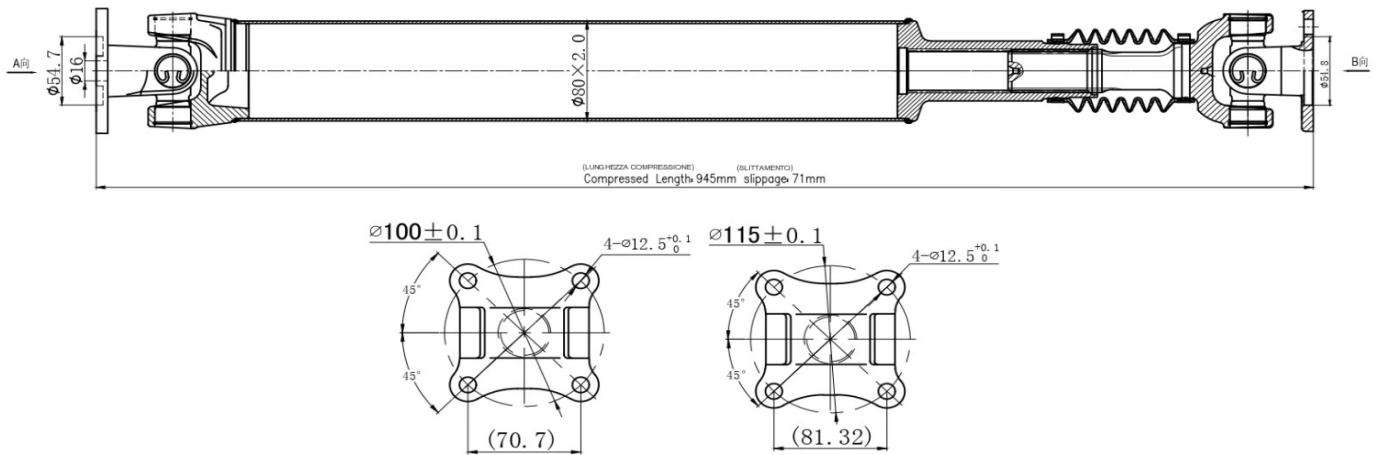

AC-0092

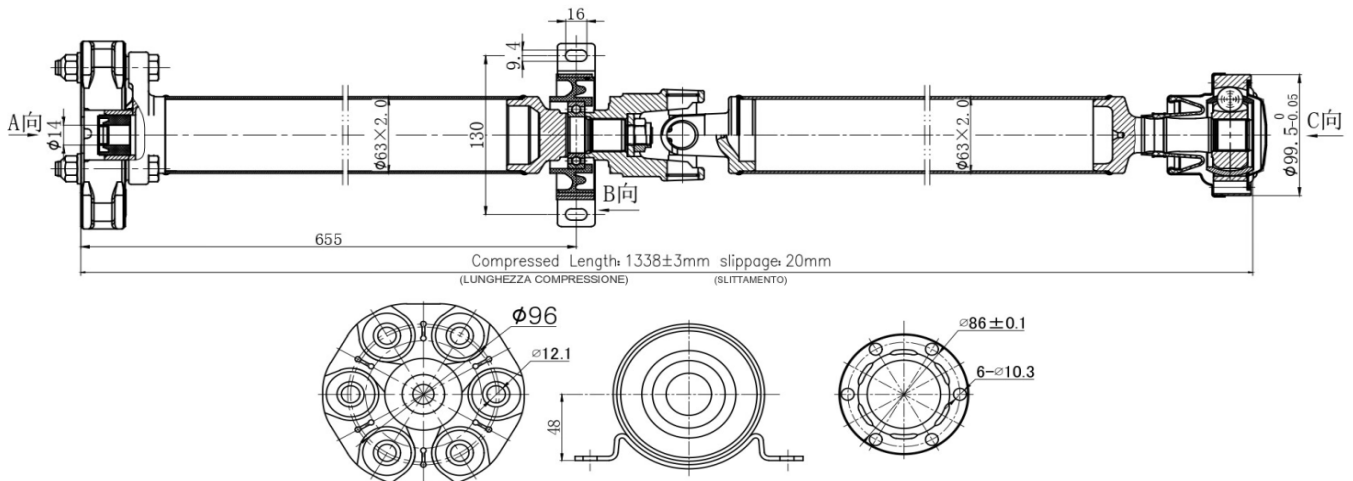

N.B.: I CODICI O.E. ED IL LORO TESTO SONO RIPORTATI SOLO A TITOLO INDICATIVO
THE O.E. CODES AND THEIR TEXT ARE REPORTED ONLY FOR INDICATIVE PURPOSE

DISEGNI TECNICI - TECHNICAL DRAWINGS

AC-0093

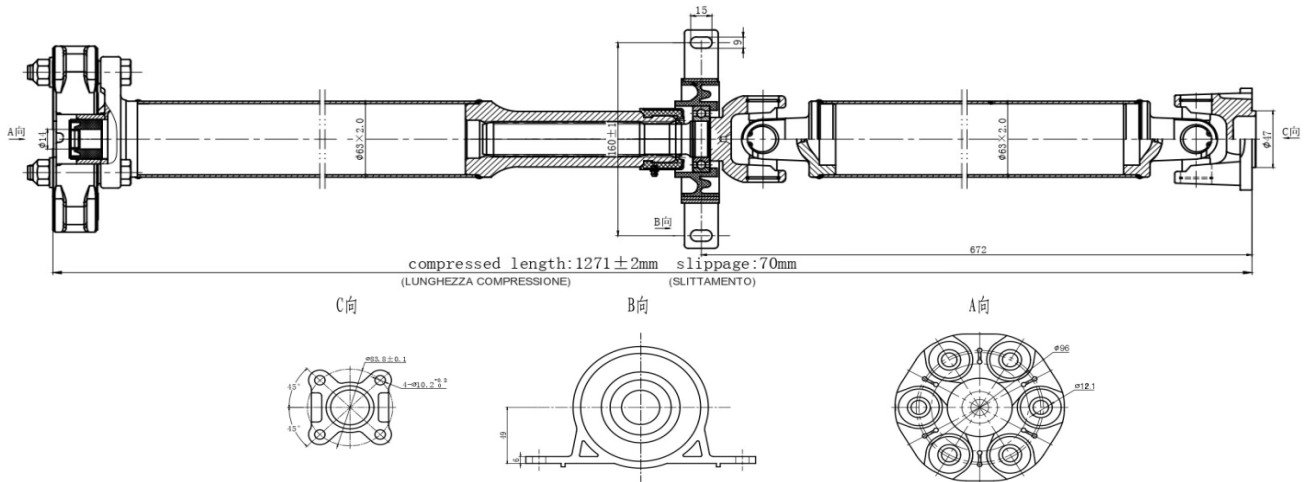

AC-0094

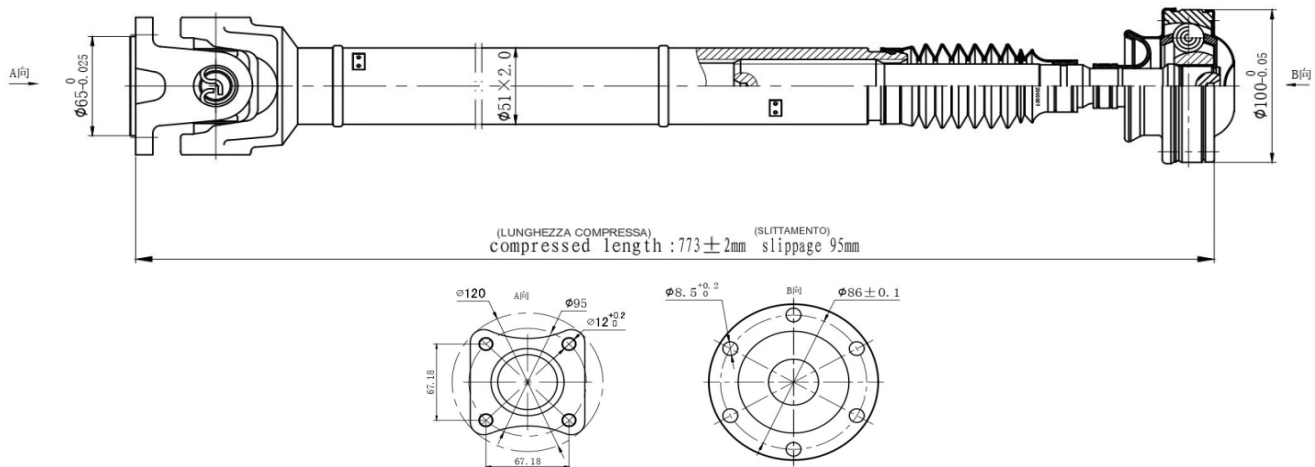

AC-0095

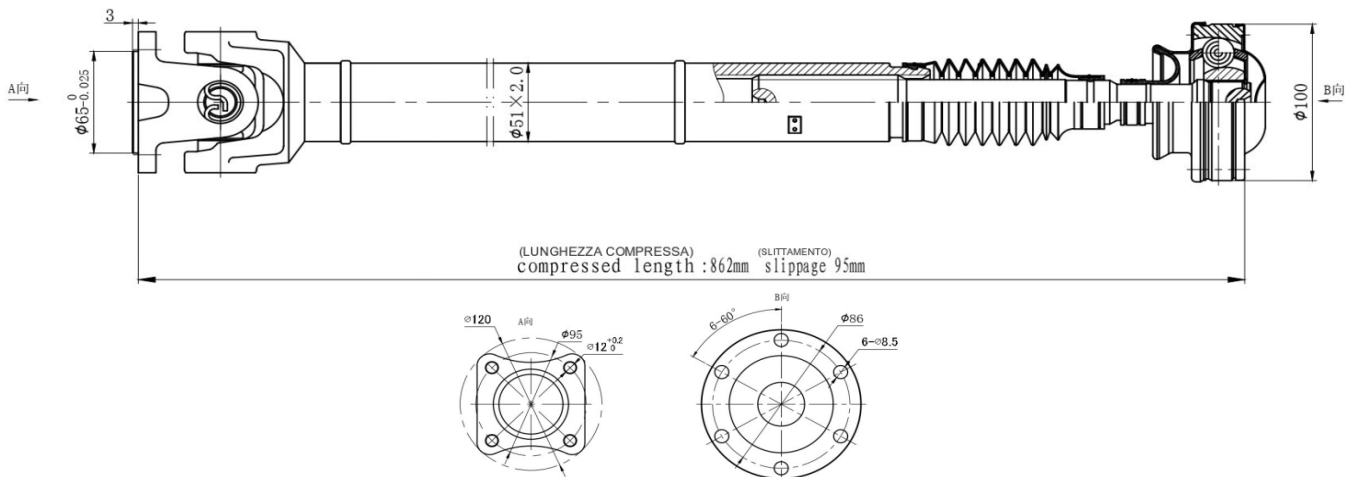

N.B.: I CODICI O.E. ED IL LORO TESTO SONO RIPOSTATI SOLO A TITOLO INDICATIVO
 THE O.E. CODES AND THEIR TEXT ARE REPORTED ONLY FOR INDICATIVE PURPOSE

DISEGNI TECNICI - TECHNICAL DRAWINGS

AC-0097

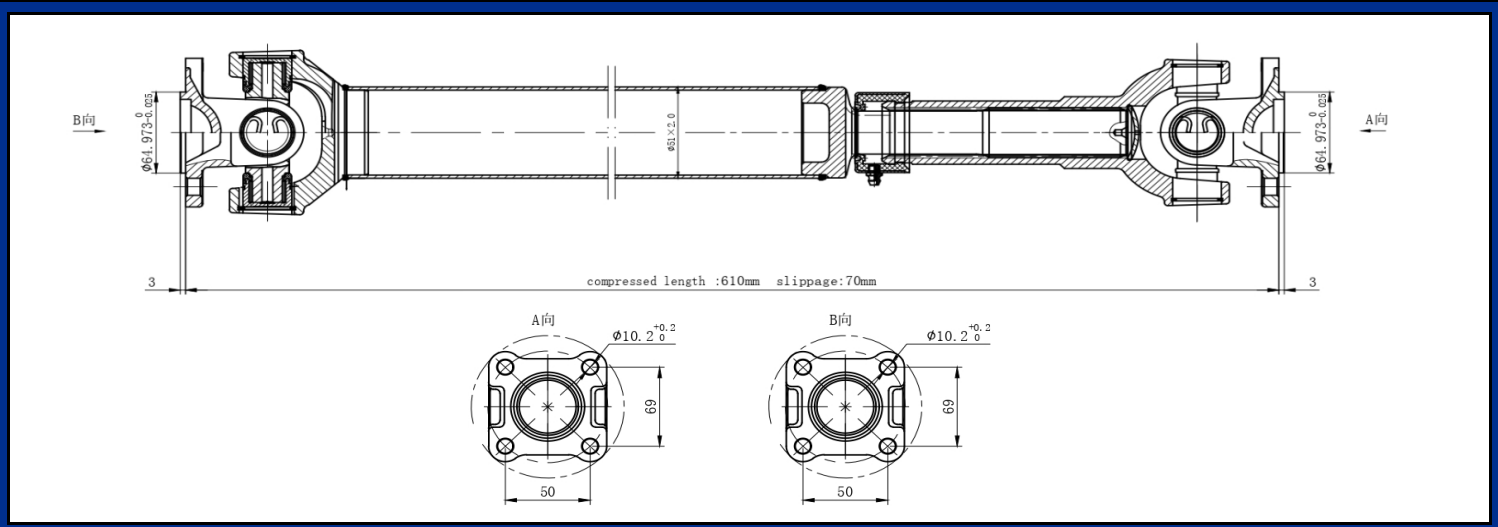

AC-0098

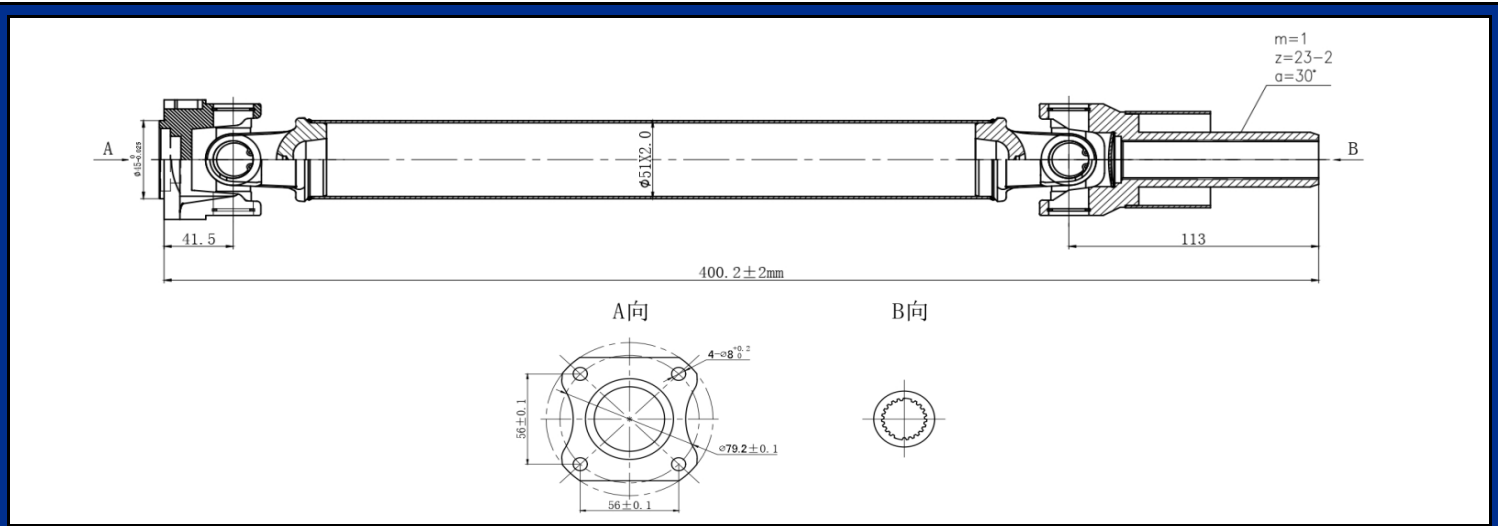

AC-0099

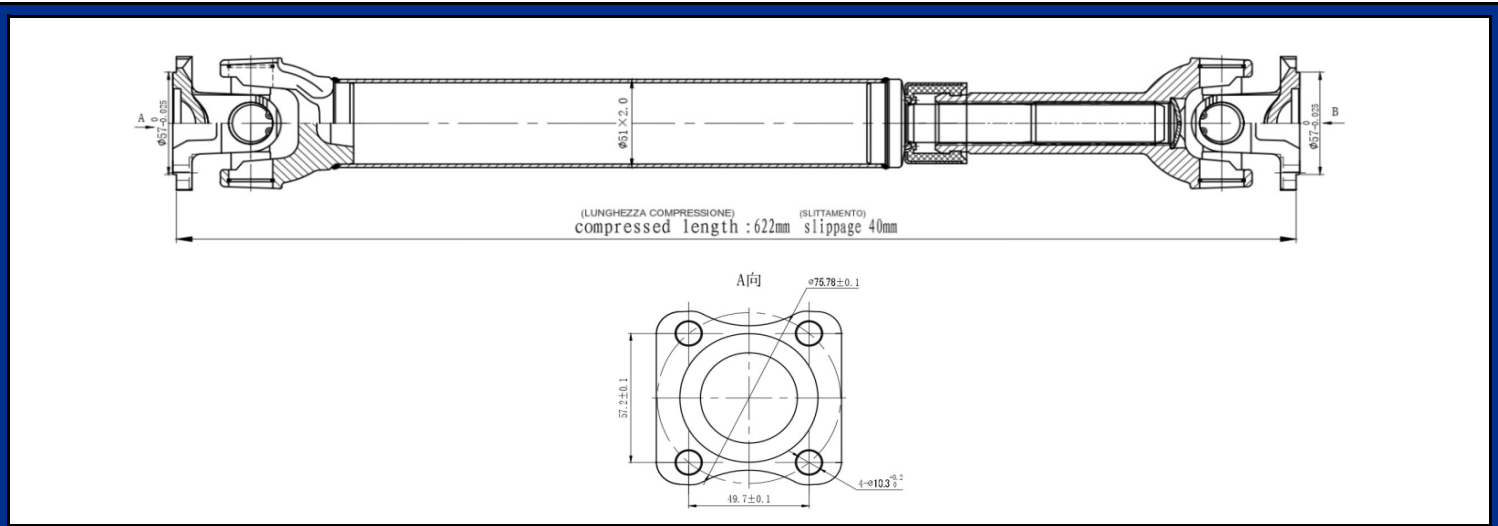

N.B.: I CODICI O.E. ED IL LORO TESTO SONO RIPORTATI SOLO A TITOLO INDICATIVO
THE O.E. CODES AND THEIR TEXT ARE REPORTED ONLY FOR INDICATIVE PURPOSE

DISEGNI TECNICI - TECHNICAL DRAWINGS

AC-0100

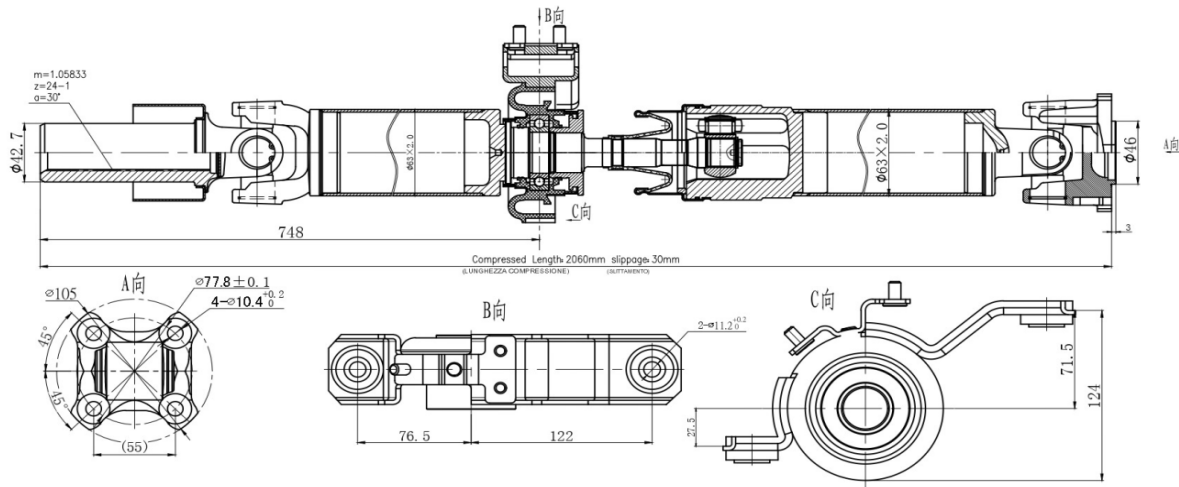

AC-0101

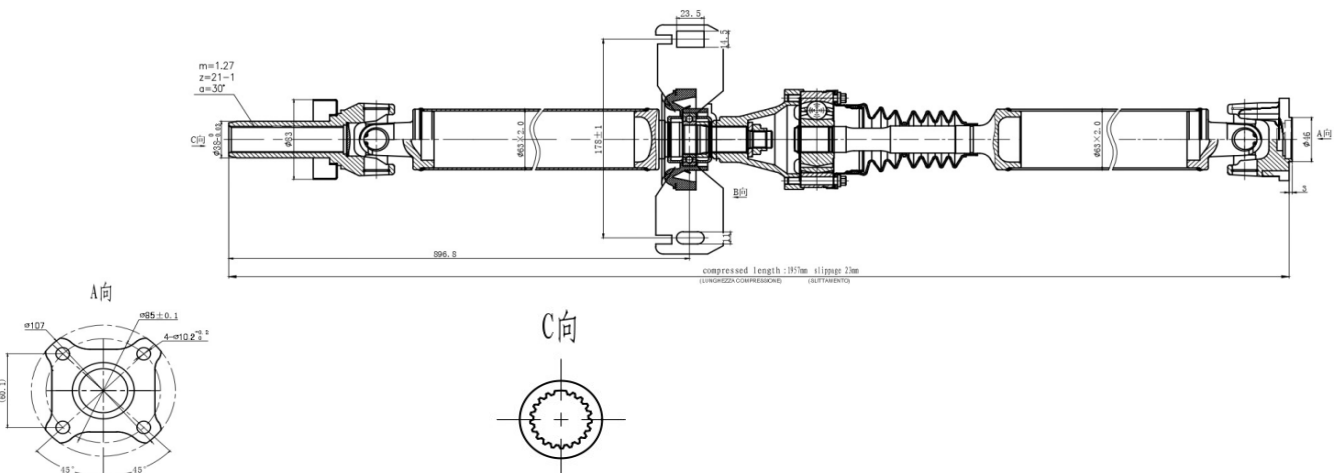

AC-0102

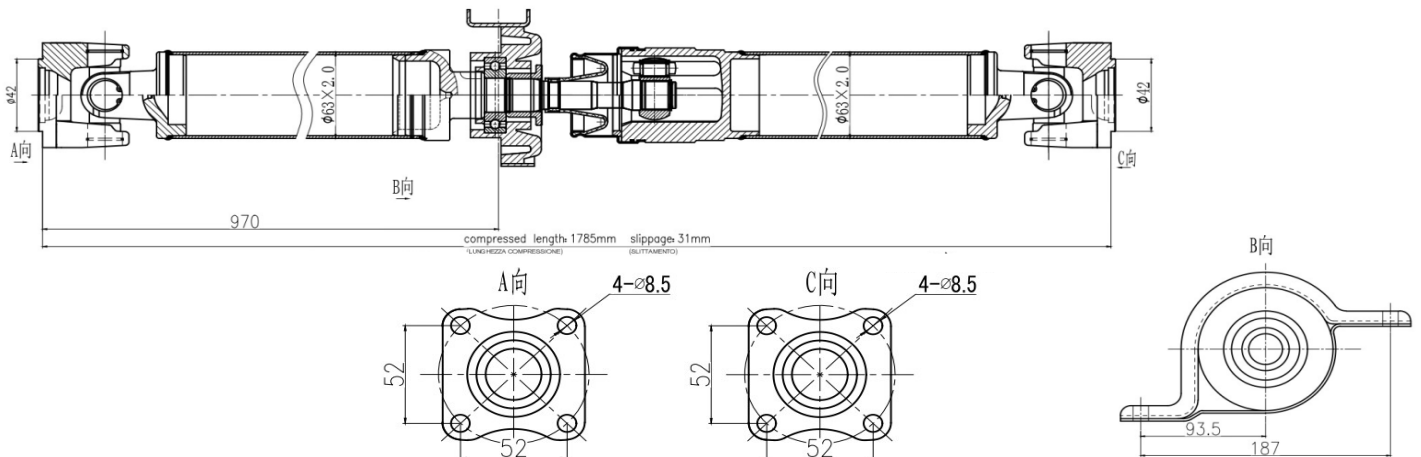

N.B.: I CODICI O.E. ED IL LORO TESTO SONO RIPORTATI SOLO A TITOLO INDICATIVO
 THE O.E. CODES AND THEIR TEXT ARE REPORTED ONLY FOR INDICATIVE PURPOSE

DISEGNI TECNICI - TECHNICAL DRAWINGS

AC-0106

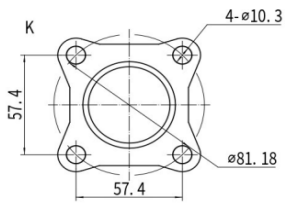
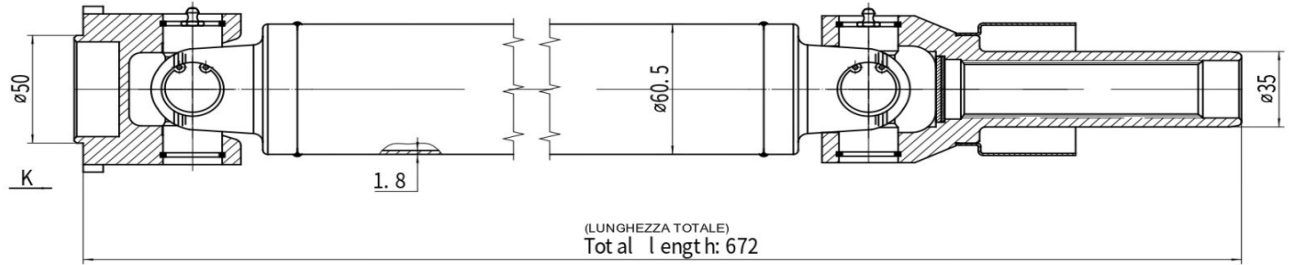

AC-0107

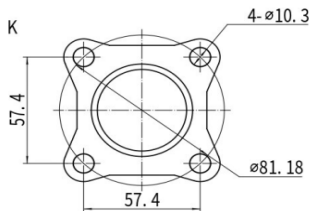
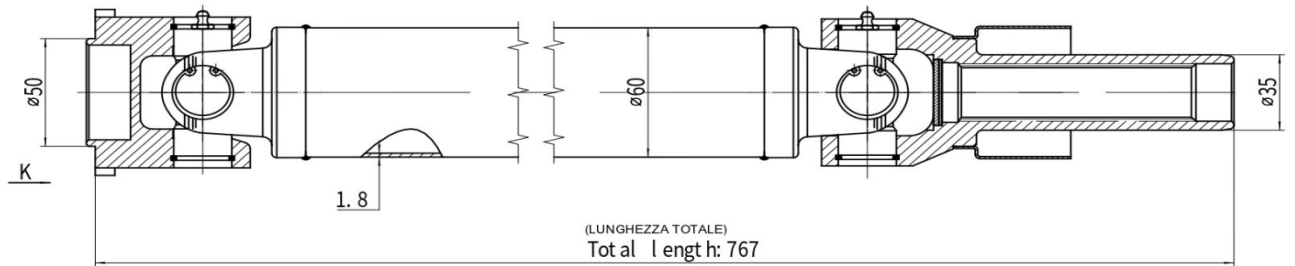

AC-0108

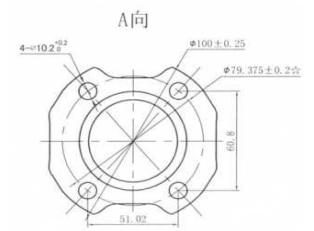
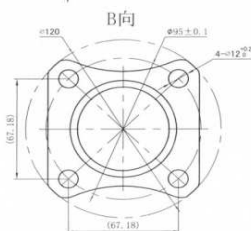
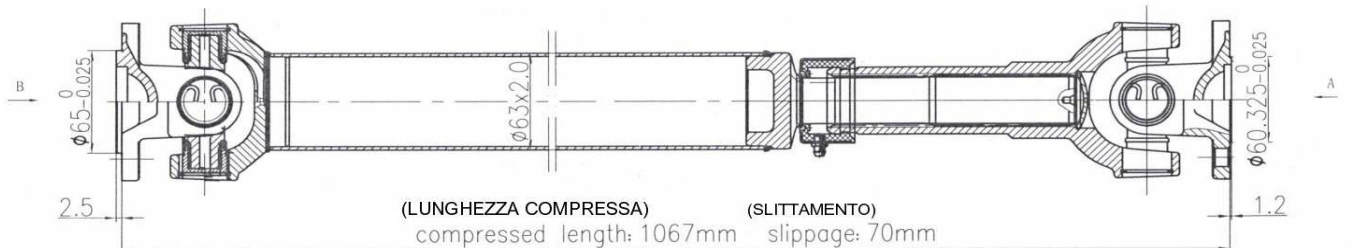

N.B.: I CODICI O.E. ED IL LORO TESTO SONO RIPORTATI SOLO A TITOLO INDICATIVO
THE O.E. CODES AND THEIR TEXT ARE REPORTED ONLY FOR INDICATIVE PURPOSE

DISEGNI TECNICI - TECHNICAL DRAWINGS

AC-0109

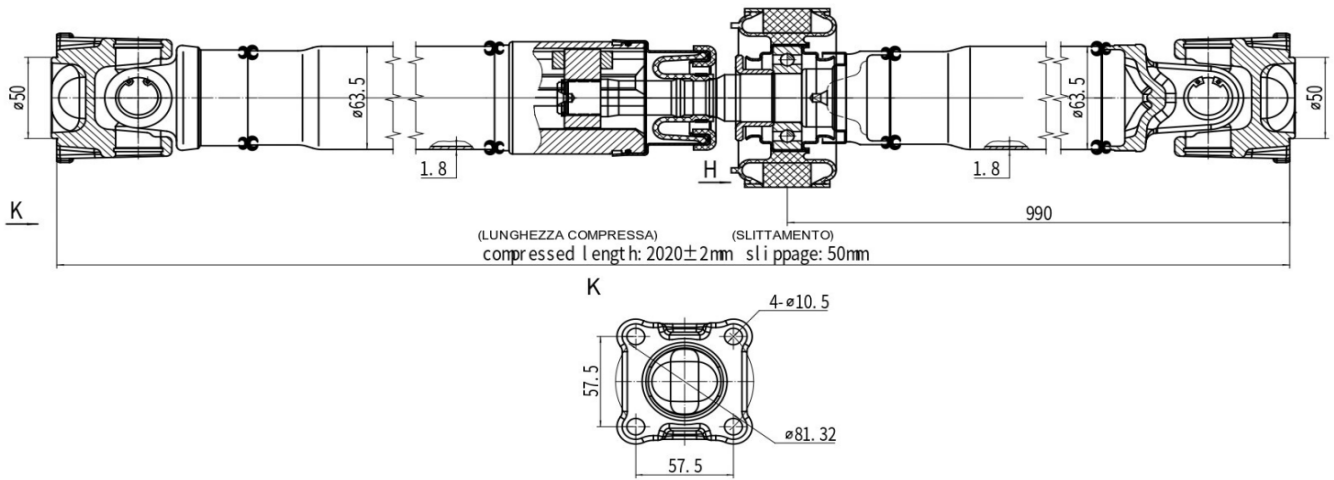

AC-0110

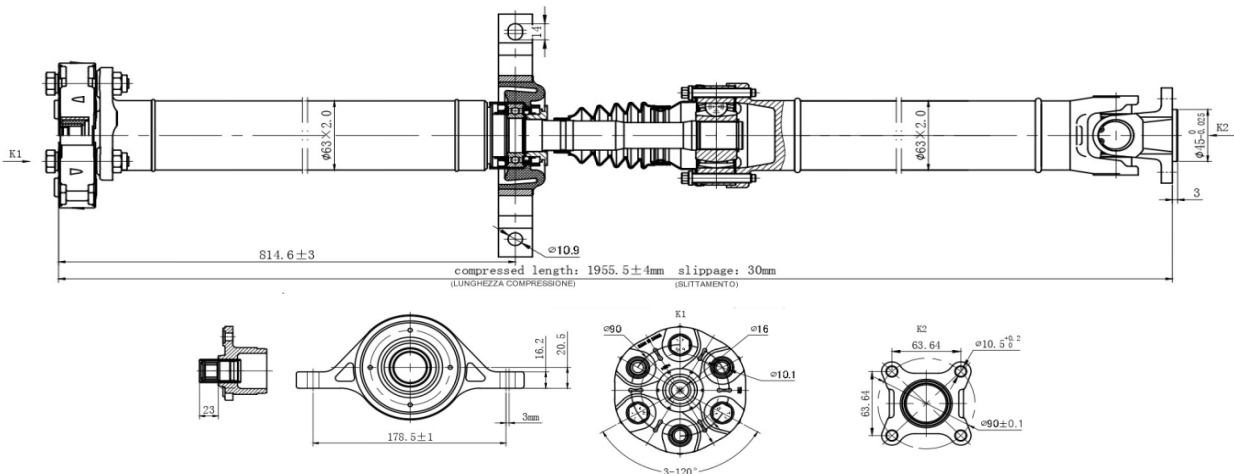

AC-0111

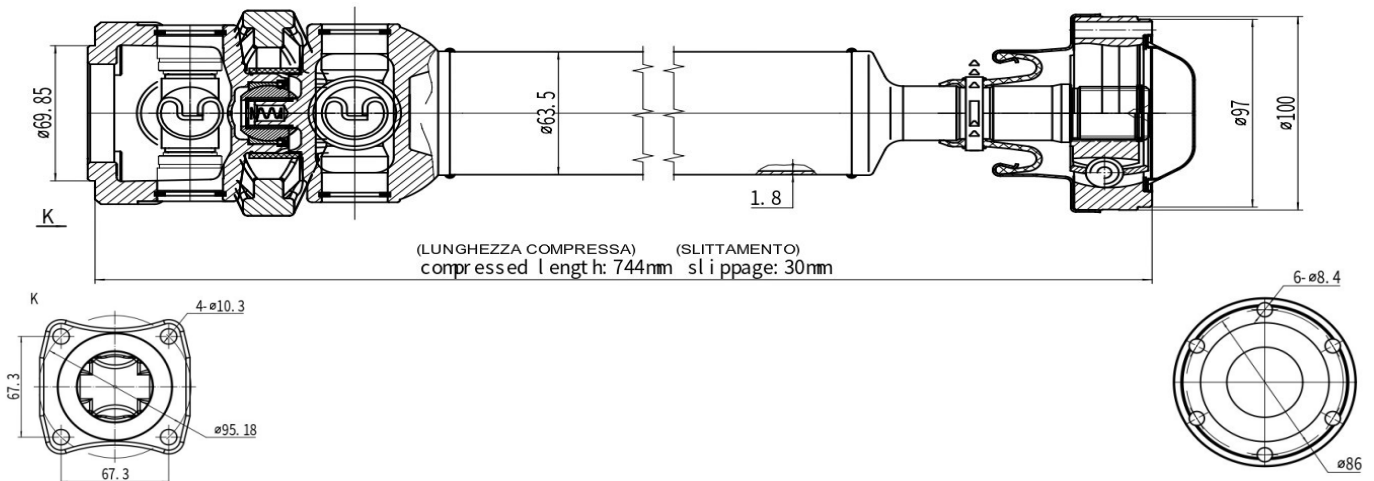

N.B.: I CODICI O.E. ED IL LORO TESTO SONO RIPORTATI SOLO A TITOLO INDICATIVO
 THE O.E. CODES AND THEIR TEXT ARE REPORTED ONLY FOR INDICATIVE PURPOSE

DISEGNI TECNICI - TECHNICAL DRAWINGS

AC-0112

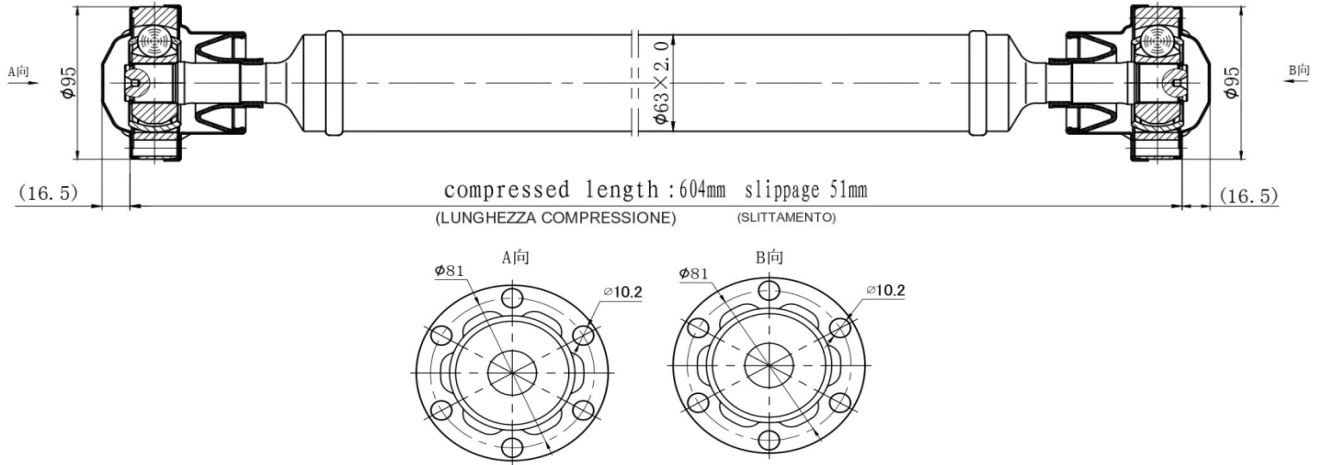

AC-0113

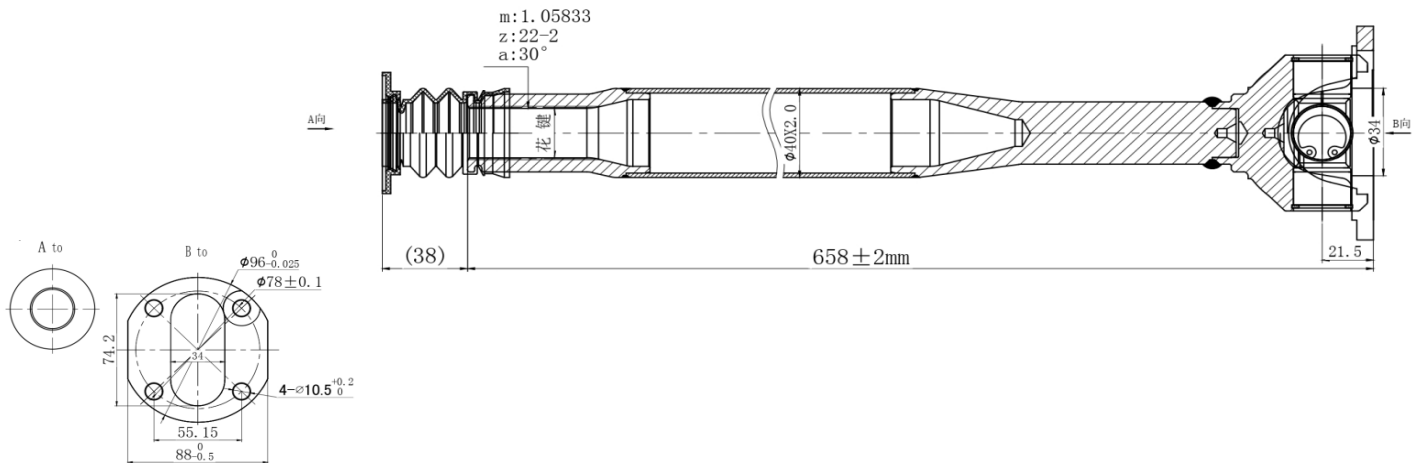

AC-0114

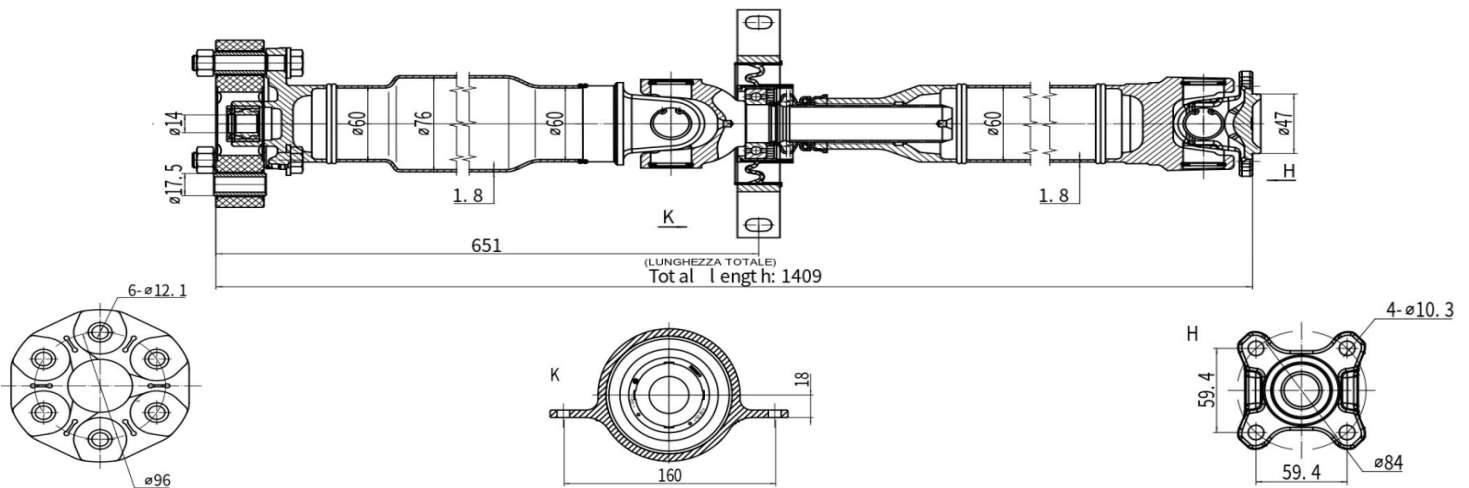

N.B.: I CODICI O.E. ED IL LORO TESTO SONO RIPORTATI SOLO A TITOLO INDICATIVO
 THE O.E. CODES AND THEIR TEXT ARE REPORTED ONLY FOR INDICATIVE PURPOSE

DISEGNI TECNICI - TECHNICAL DRAWINGS

AC-0115

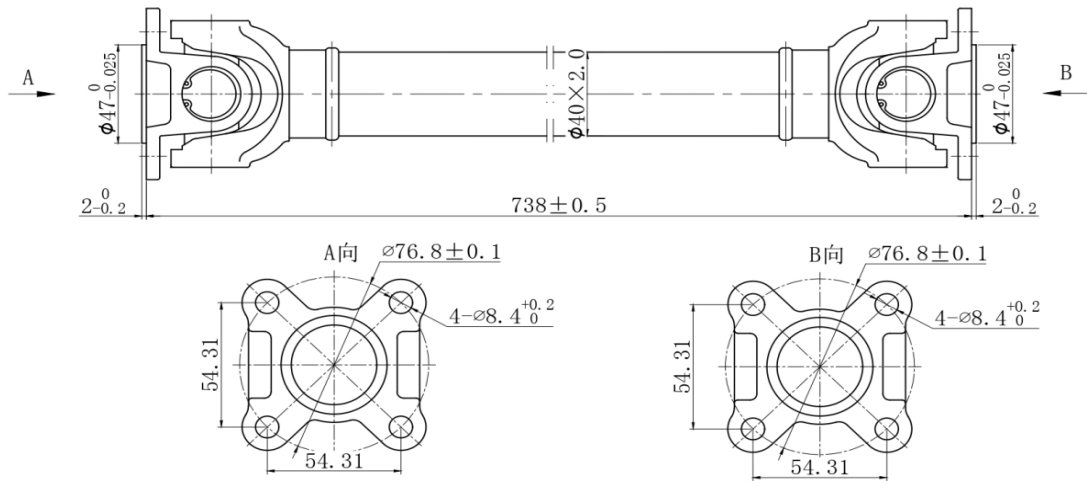

AC-0116

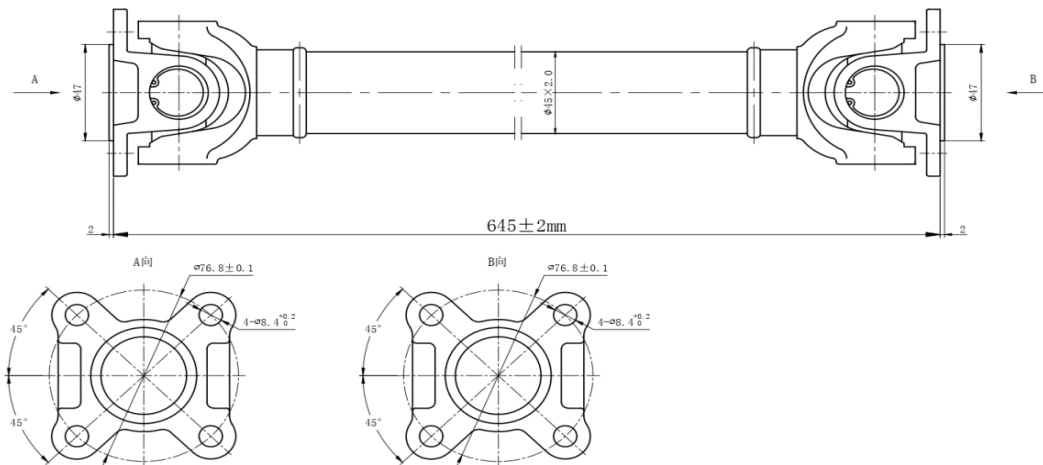

AC-0117

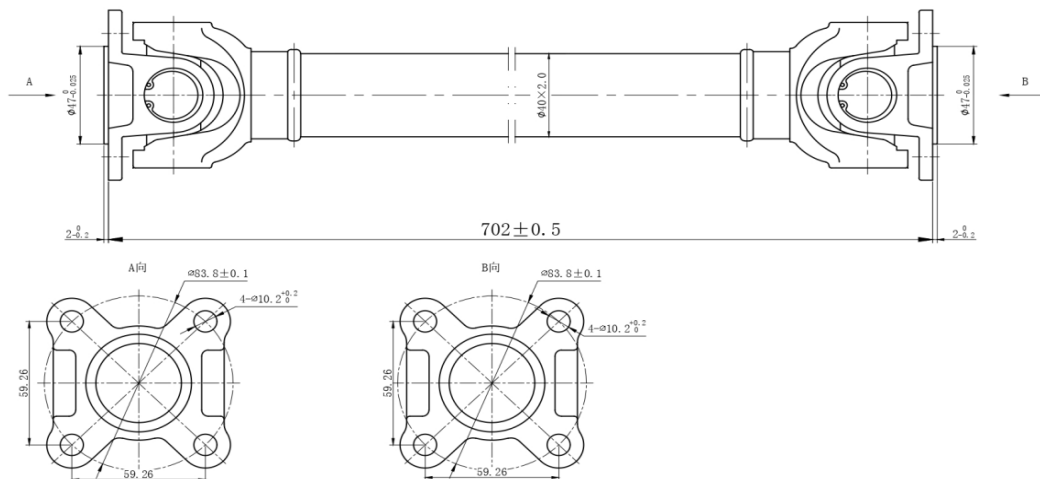

N.B.: I CODICI O.E. ED IL LORO TESTO SONO RIPORTATI SOLO A TITOLO INDICATIVO
THE O.E. CODES AND THEIR TEXT ARE REPORTED ONLY FOR INDICATIVE PURPOSE

DISEGNI TECNICI - TECHNICAL DRAWINGS

AC-0118

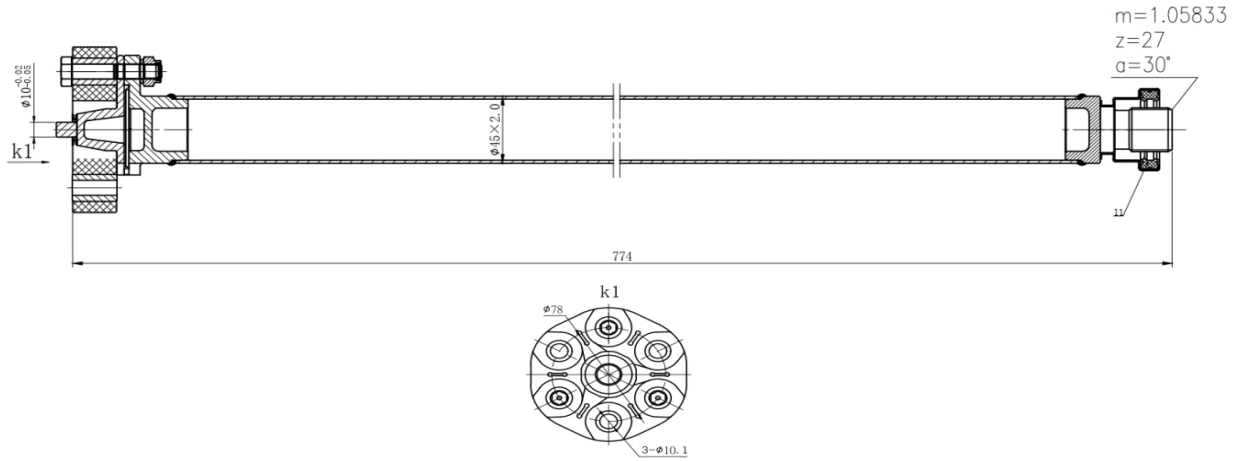

AC-0119

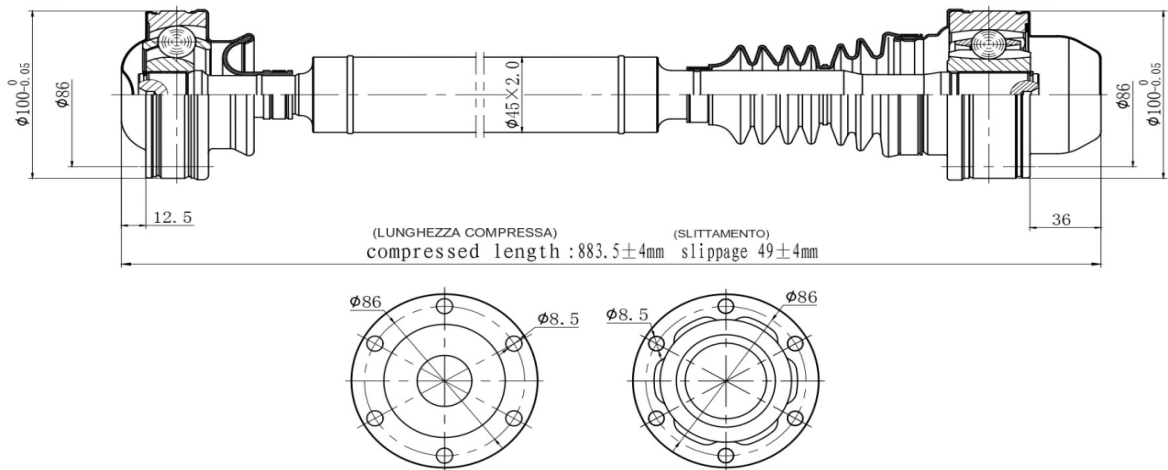

AC-0120

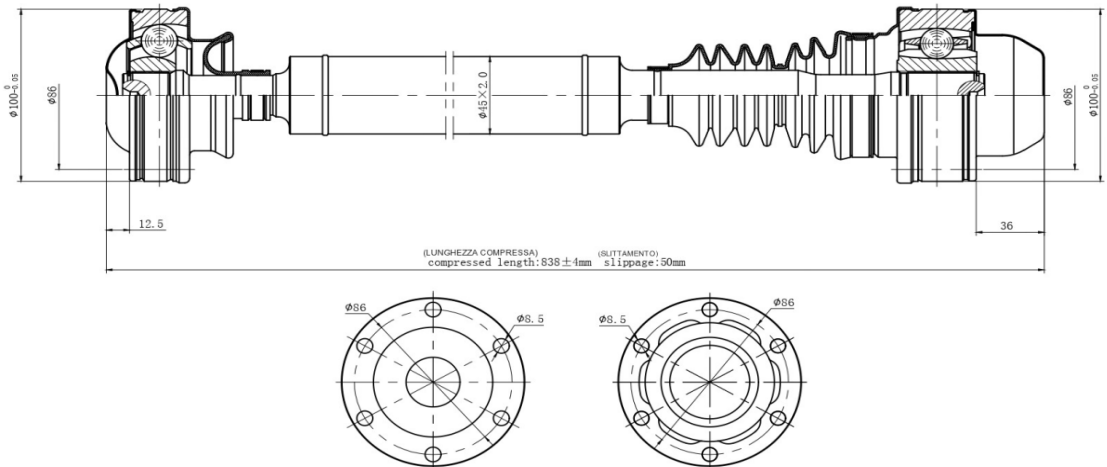

N.B.: I CODICI O.E. ED IL LORO TESTO SONO RIPORTATI SOLO A TITOLO INDICATIVO
 THE O.E. CODES AND THEIR TEXT ARE REPORTED ONLY FOR INDICATIVE PURPOSE

DISEGNI TECNICI - TECHNICAL DRAWINGS

AC-0121

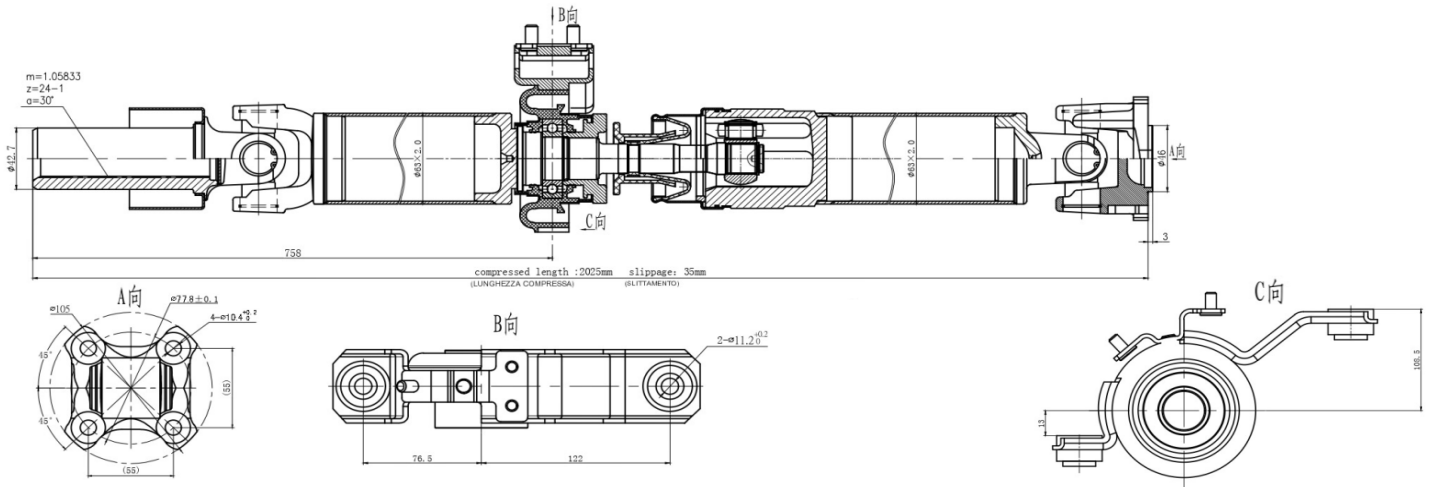

AC-0123

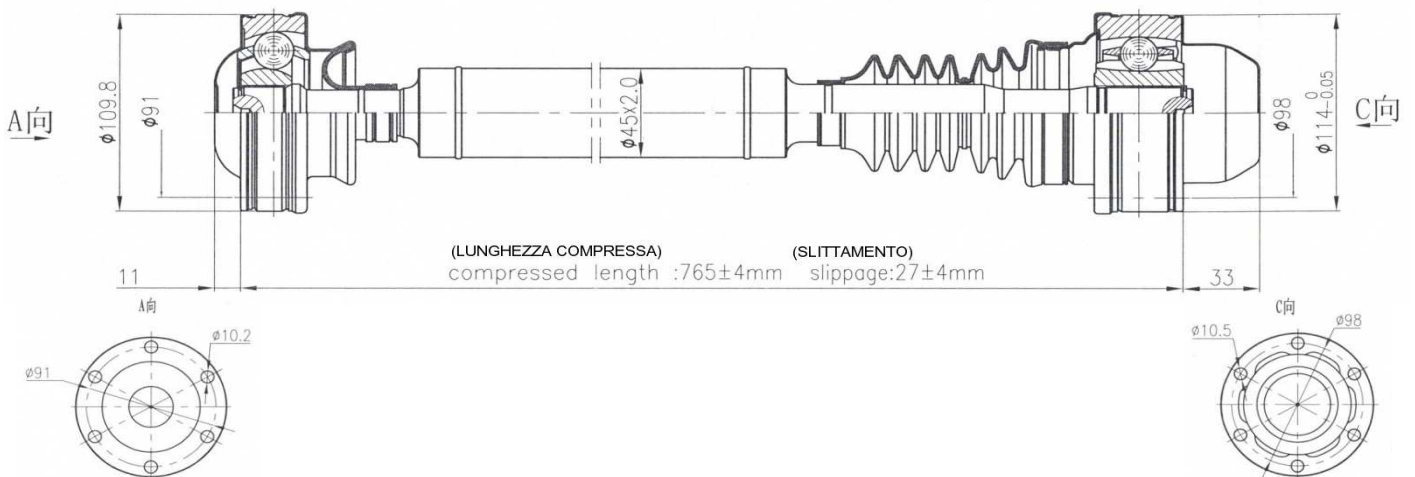

AC-0124

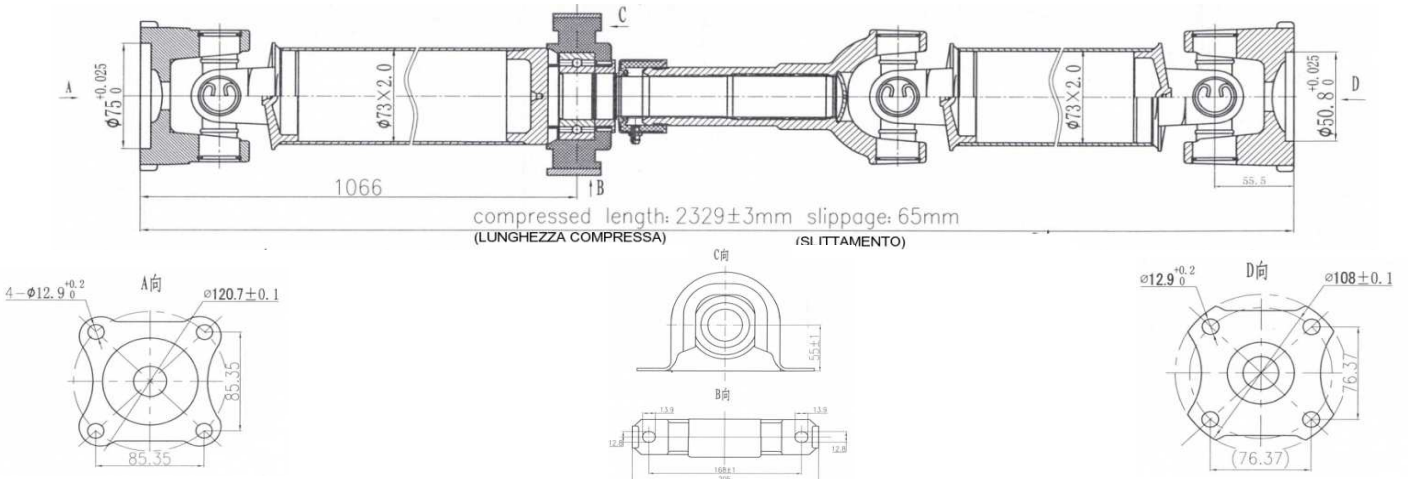

N.B.: I CODICI O.E. ED IL LORO TESTO SONO RIPORTATI SOLO A TITOLO INDICATIVO
 THE O.E. CODES AND THEIR TEXT ARE REPORTED ONLY FOR INDICATIVE PURPOSE

DISEGNI TECNICI - TECHNICAL DRAWINGS

AC-0125

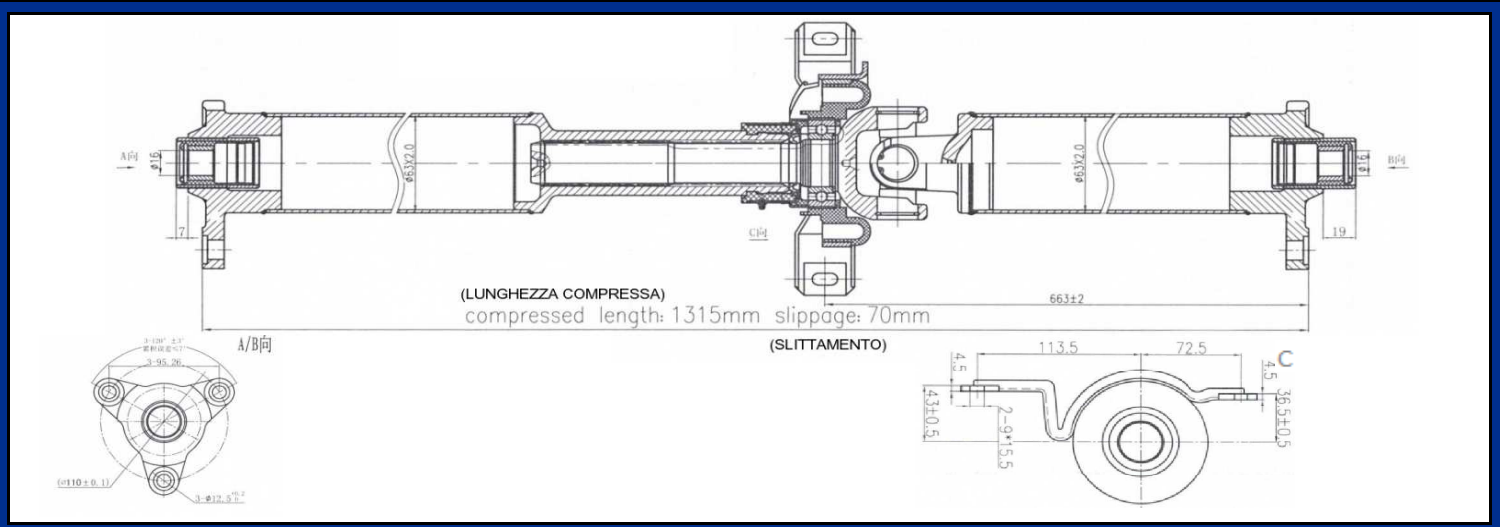

AC-0126

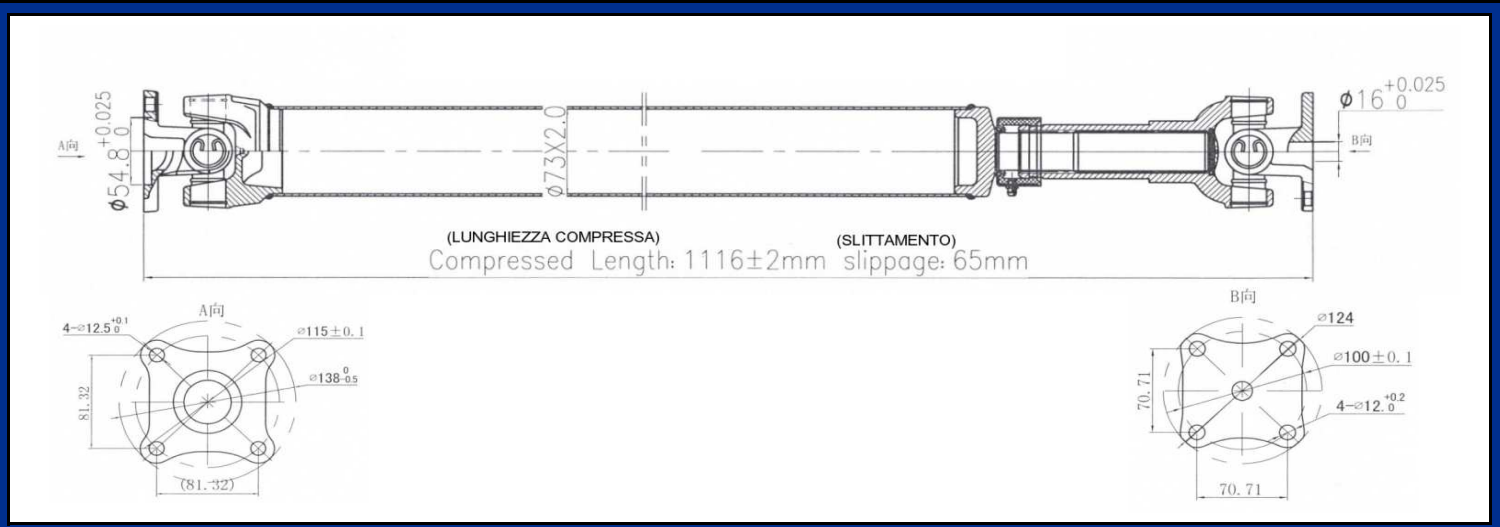

AC-0127

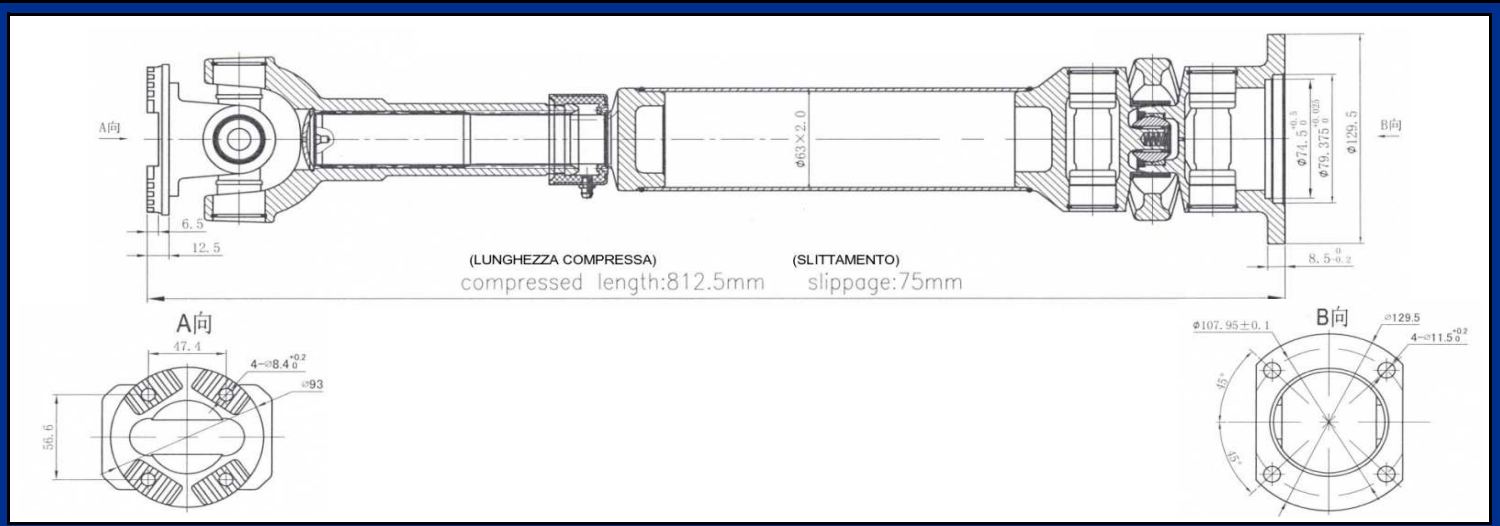

N.B.: I CODICI O.E. ED IL LORO TESTO SONO RIPORTATI SOLO A TITOLO INDICATIVO
THE O.E. CODES AND THEIR TEXT ARE REPORTED ONLY FOR INDICATIVE PURPOSE

DISEGNI TECNICI - TECHNICAL DRAWINGS

AC-0128

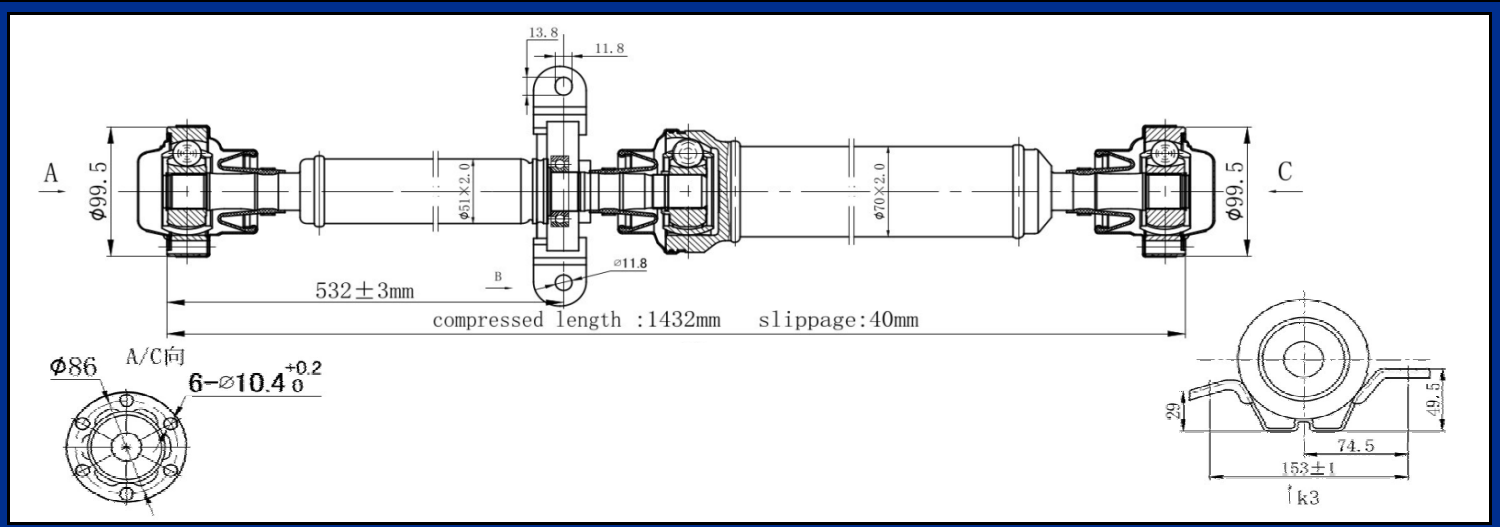

AC-0129

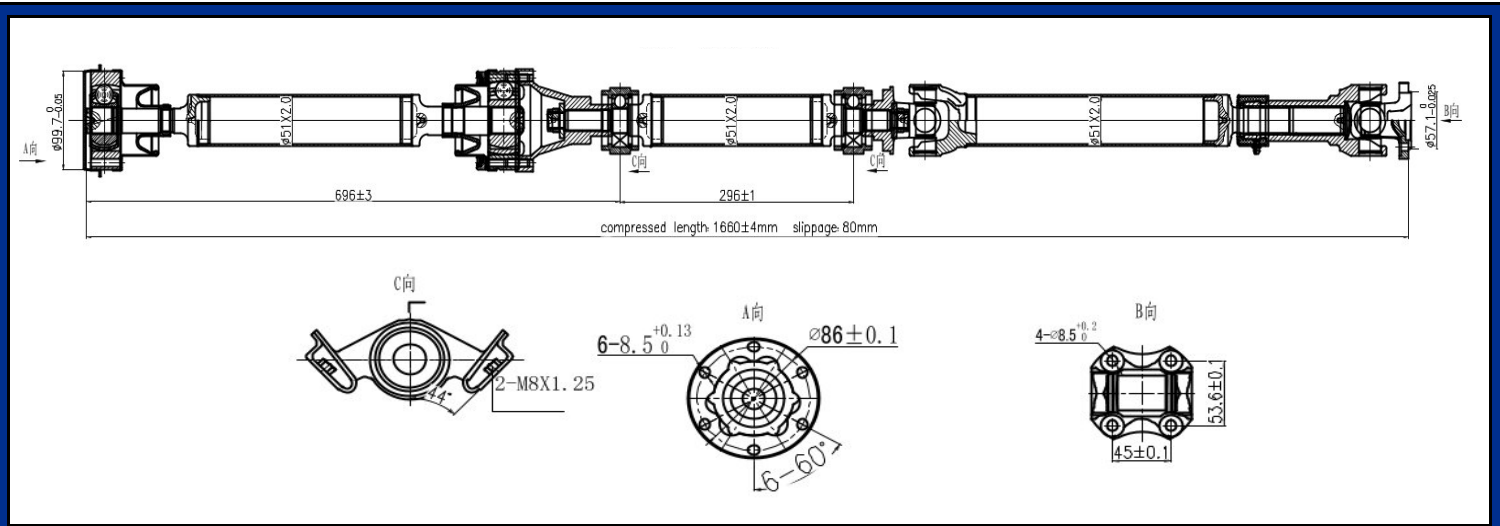

AC-0130

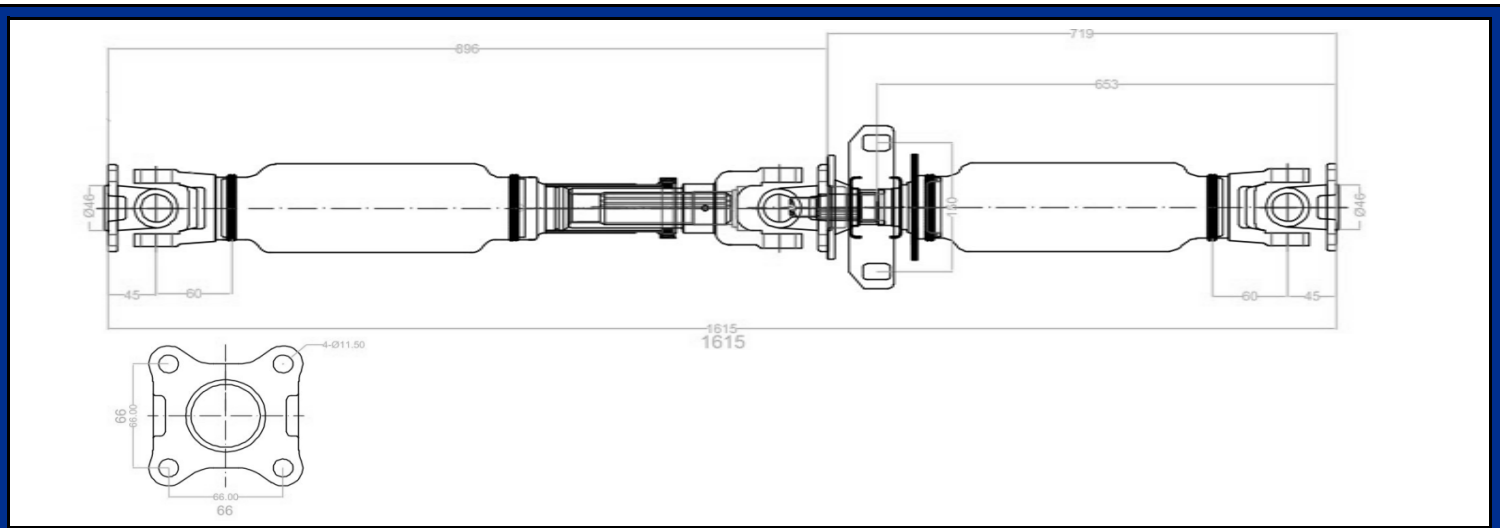

N.B.: I CODICI O.E. ED IL LORO TESTO SONO RIPORTATI SOLO A TITOLO INDICATIVO
 THE O.E. CODES AND THEIR TEXT ARE REPORTED ONLY FOR INDICATIVE PURPOSE

DISEGNI TECNICI - TECHNICAL DRAWINGS

AC-0131

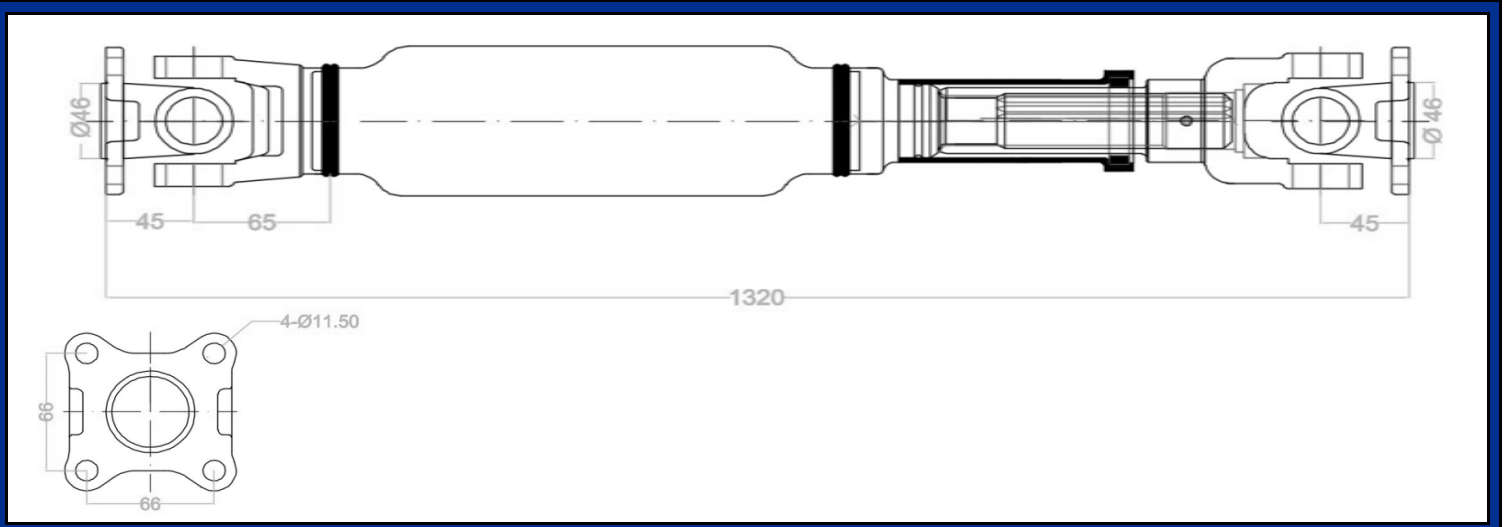

AC-0132

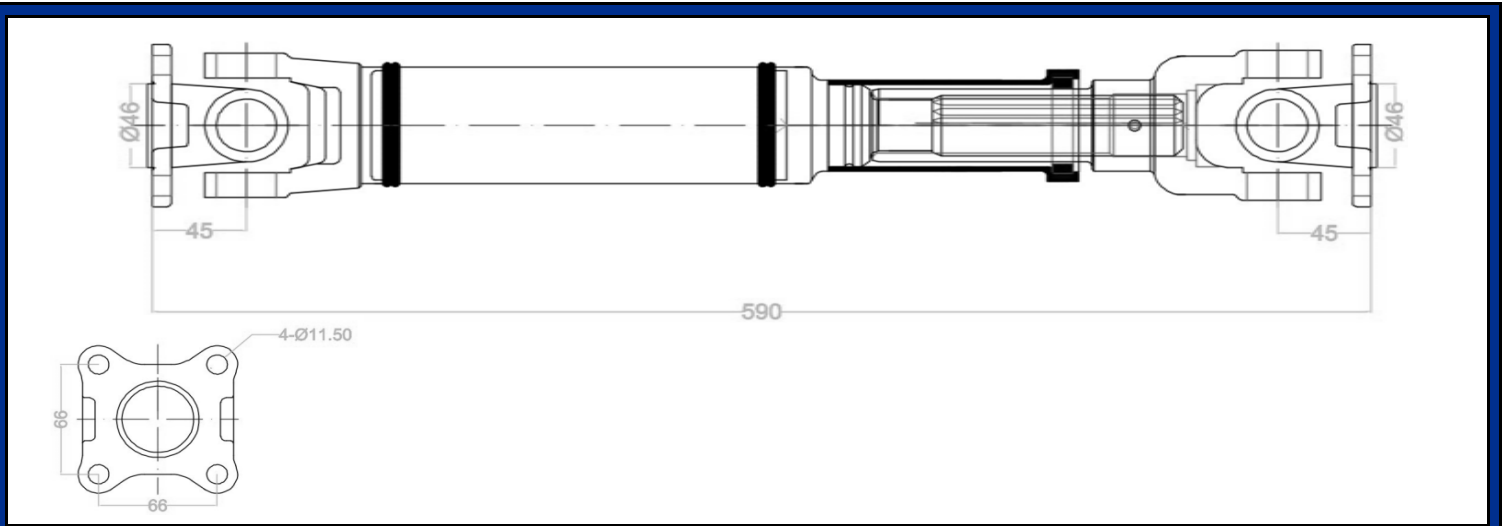

AC-0133

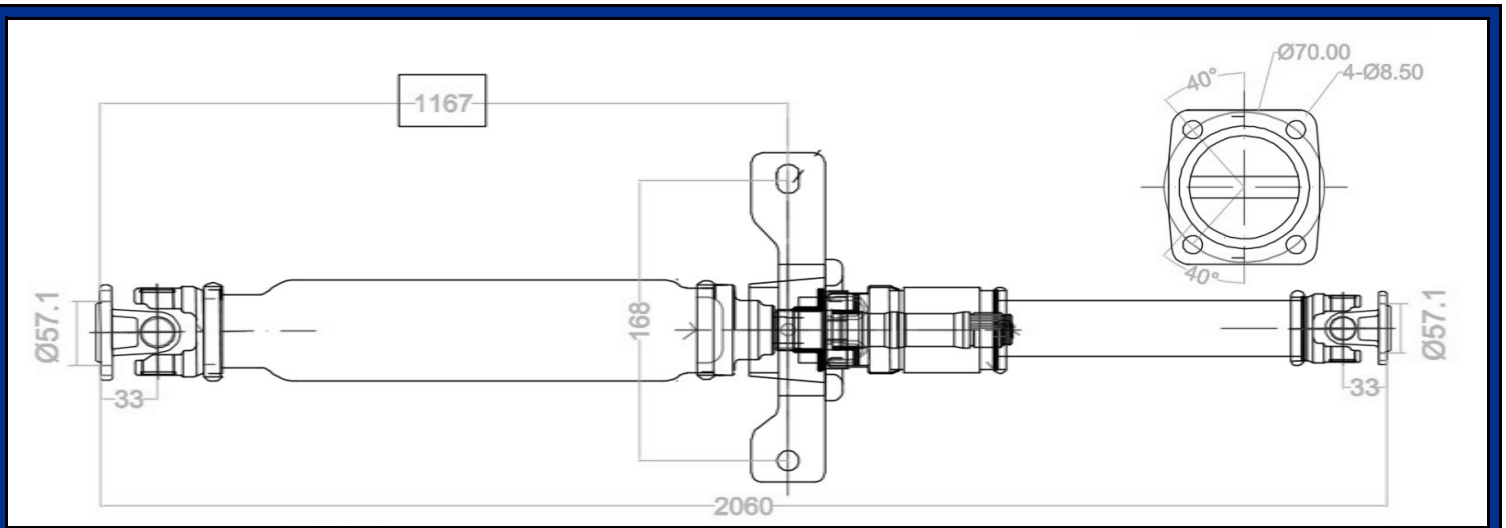

N.B.: I CODICI O.E. ED IL LORO TESTO SONO RIPORTATI SOLO A TITOLO INDICATIVO
 THE O.E. CODES AND THEIR TEXT ARE REPORTED ONLY FOR INDICATIVE PURPOSE

DISEGNI TECNICI - TECHNICAL DRAWINGS

AC-0137

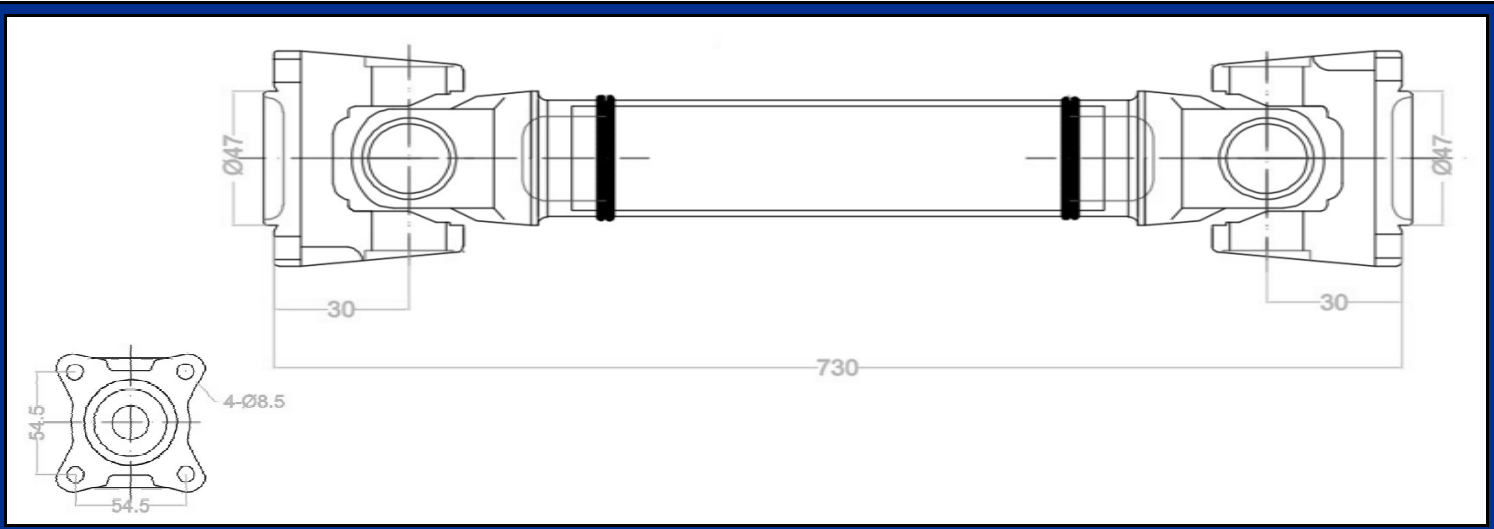

AC-0138

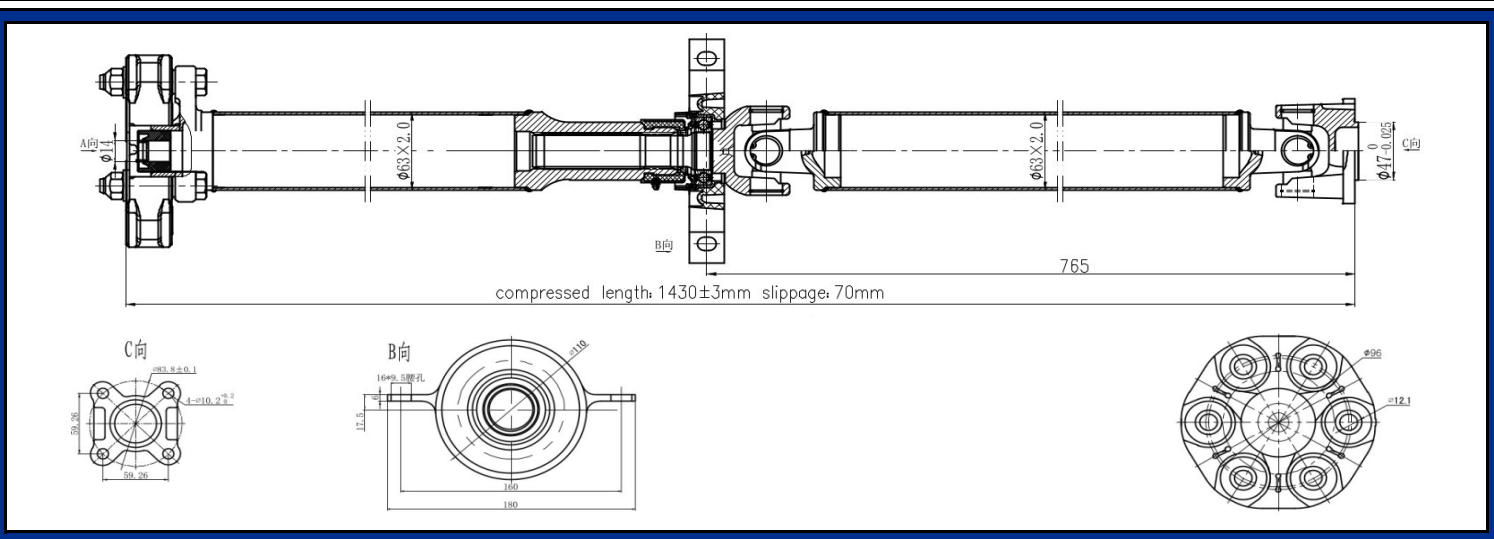

AC-0139

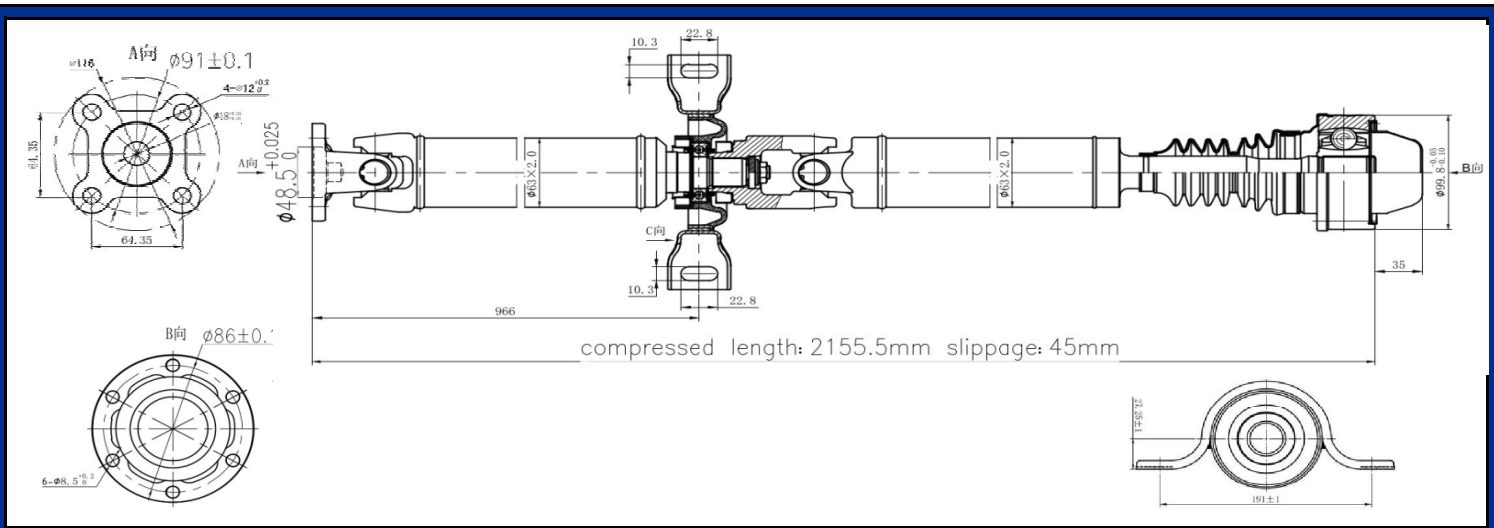

N.B.: I CODICI O.E. ED IL LORO TESTO SONO RIPORTATI SOLO A TITOLO INDICATIVO
 THE O.E. CODES AND THEIR TEXT ARE REPORTED ONLY FOR INDICATIVE PURPOSE

DISEGNI TECNICI - TECHNICAL DRAWINGS

AC-0140

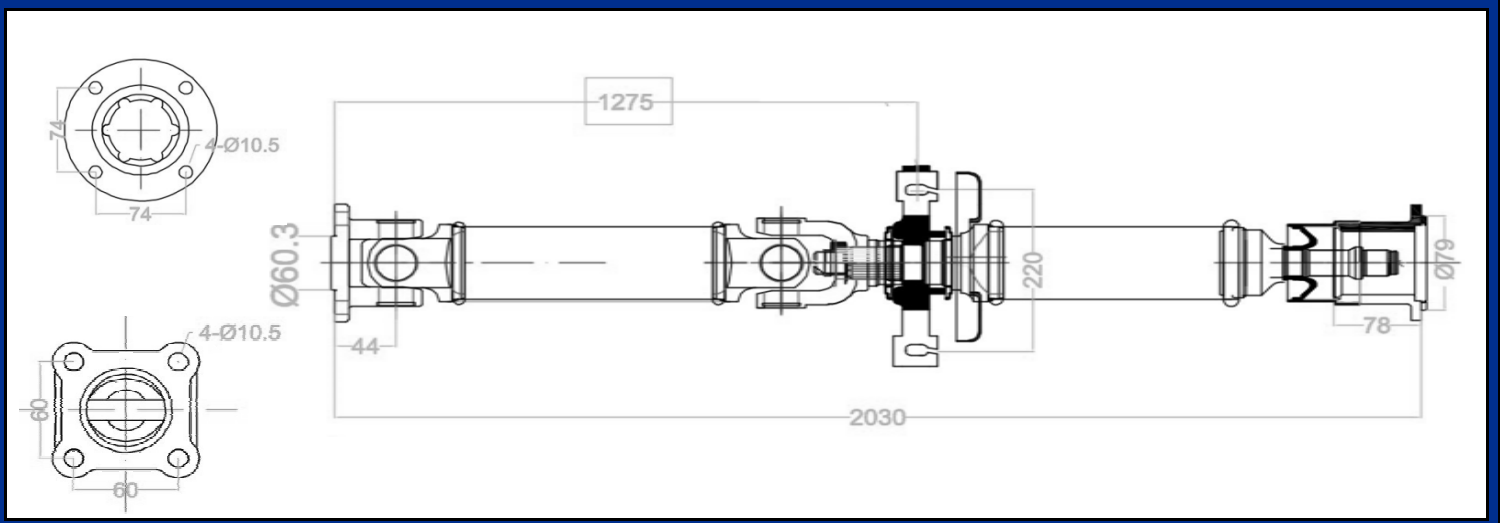

AC-0141

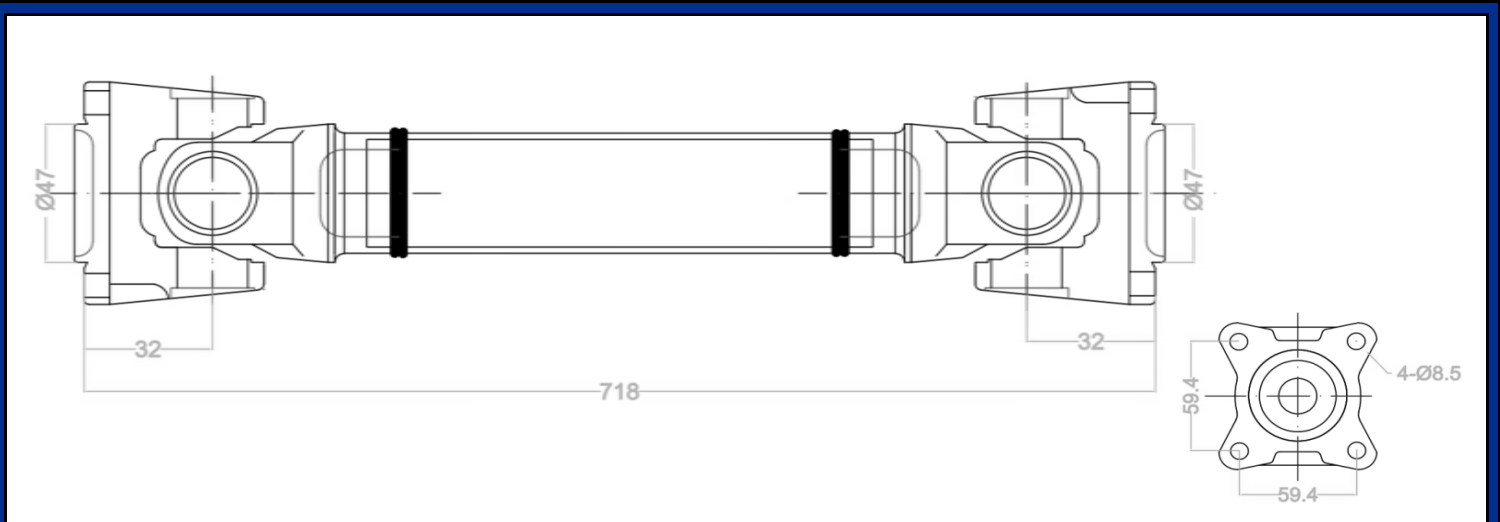

AC-0142

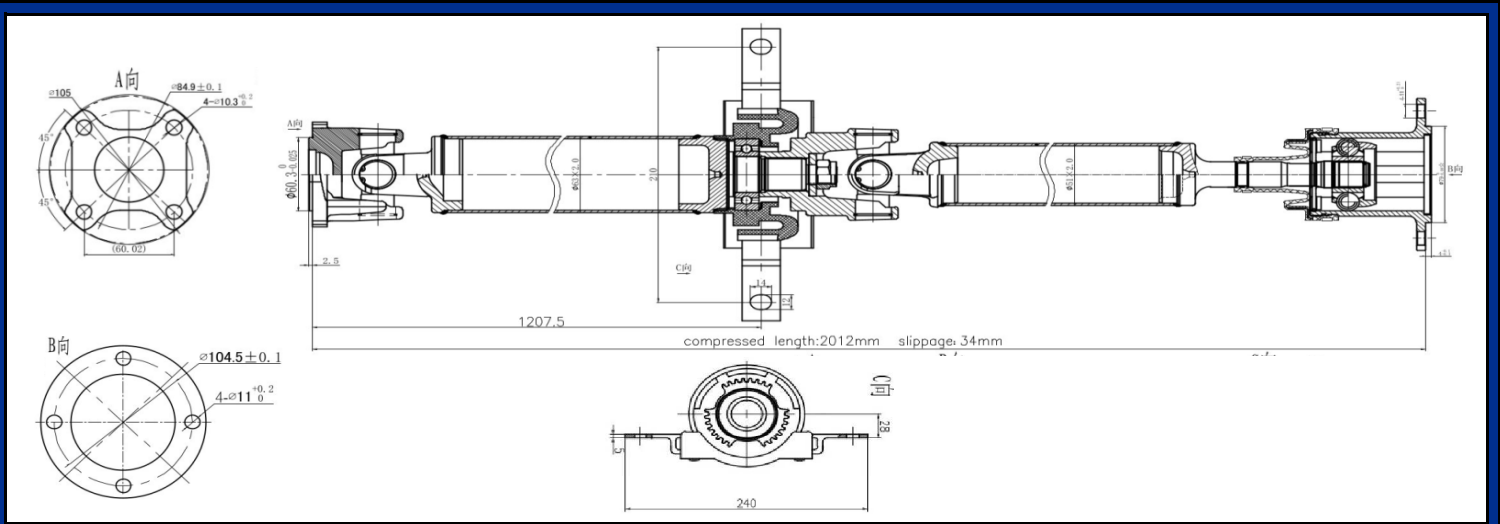

N.B.: I CODICI O.E. ED IL LORO TESTO SONO RIPORTATI SOLO A TITOLO INDICATIVO
 THE O.E. CODES AND THEIR TEXT ARE REPORTED ONLY FOR INDICATIVE PURPOSE

DISEGNI TECNICI - TECHNICAL DRAWINGS

AC-0143

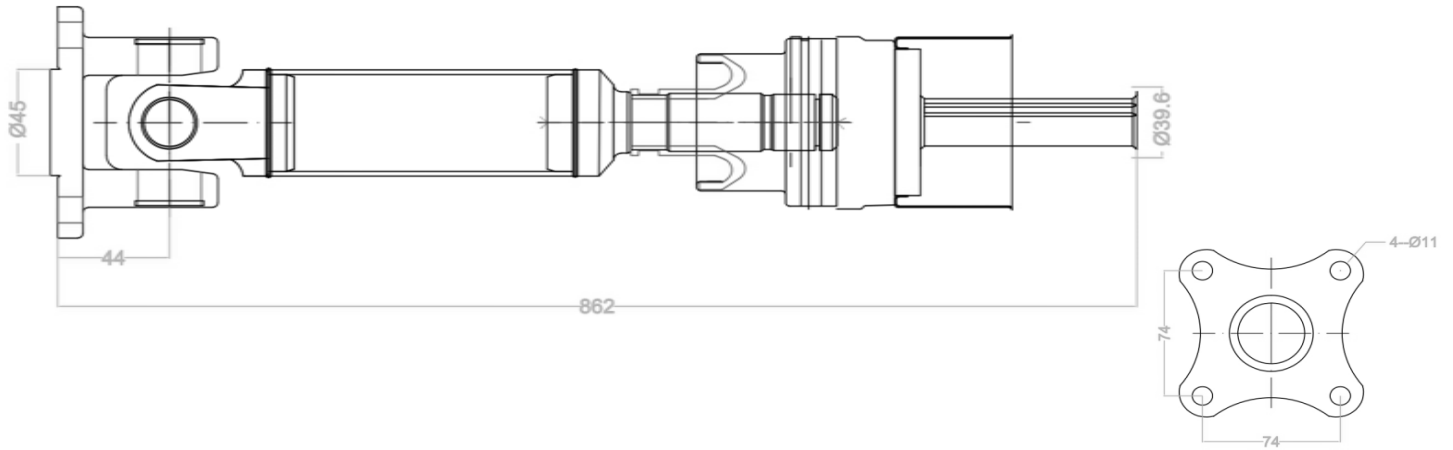

AC-0144

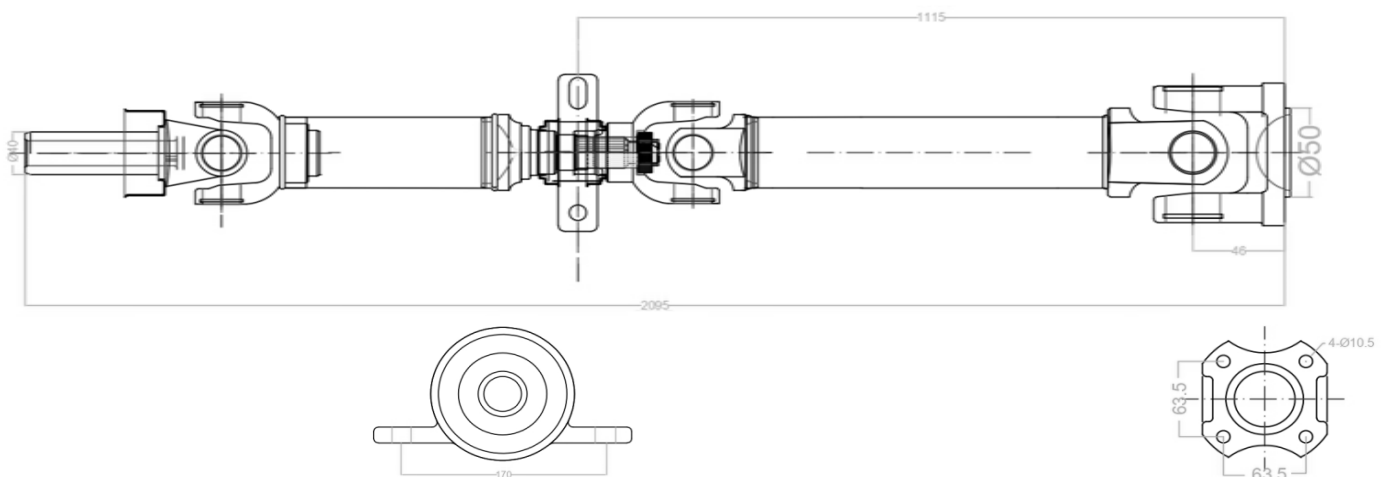

AC-0145

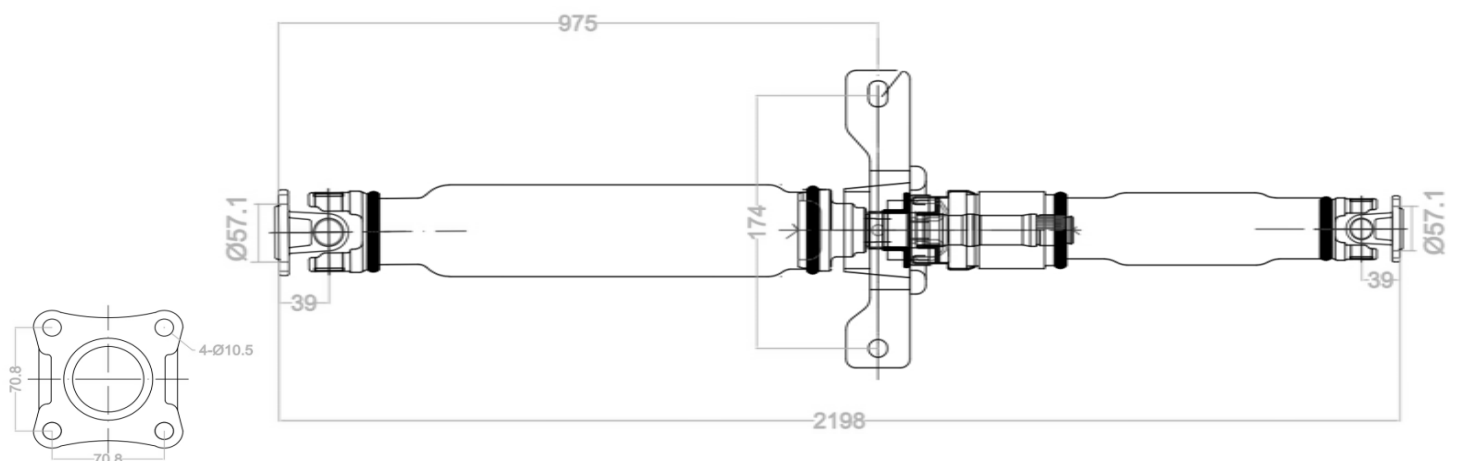

N.B.: I CODICI O.E. ED IL LORO TESTO SONO RIPORTATI SOLO A TITOLO INDICATIVO
 THE O.E. CODES AND THEIR TEXT ARE REPORTED ONLY FOR INDICATIVE PURPOSE

DISEGNI TECNICI - TECHNICAL DRAWINGS

AC-0146

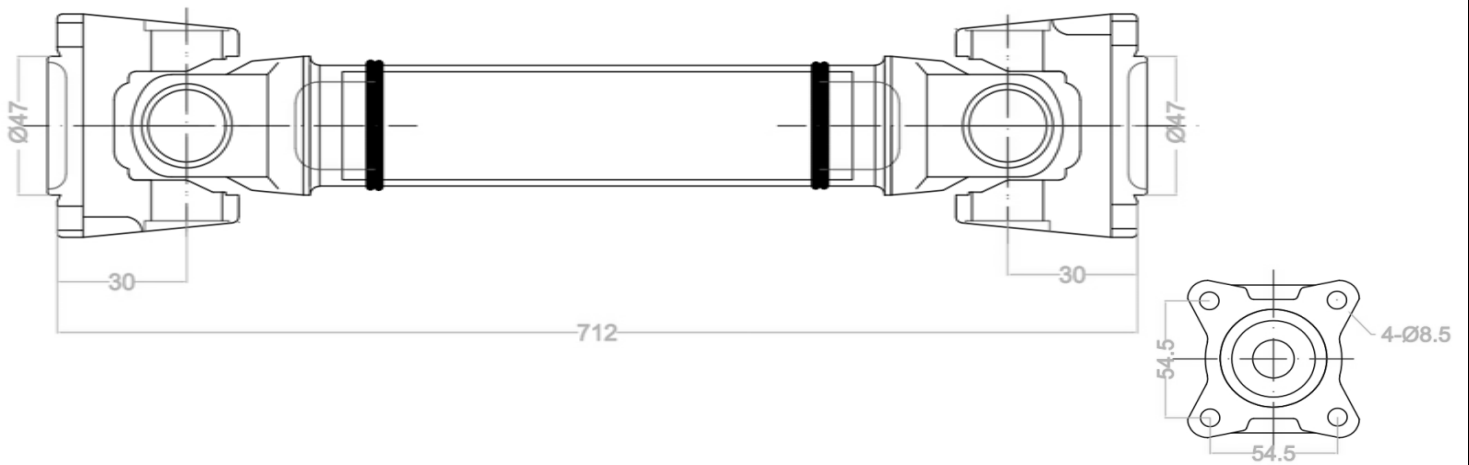

AC-0147

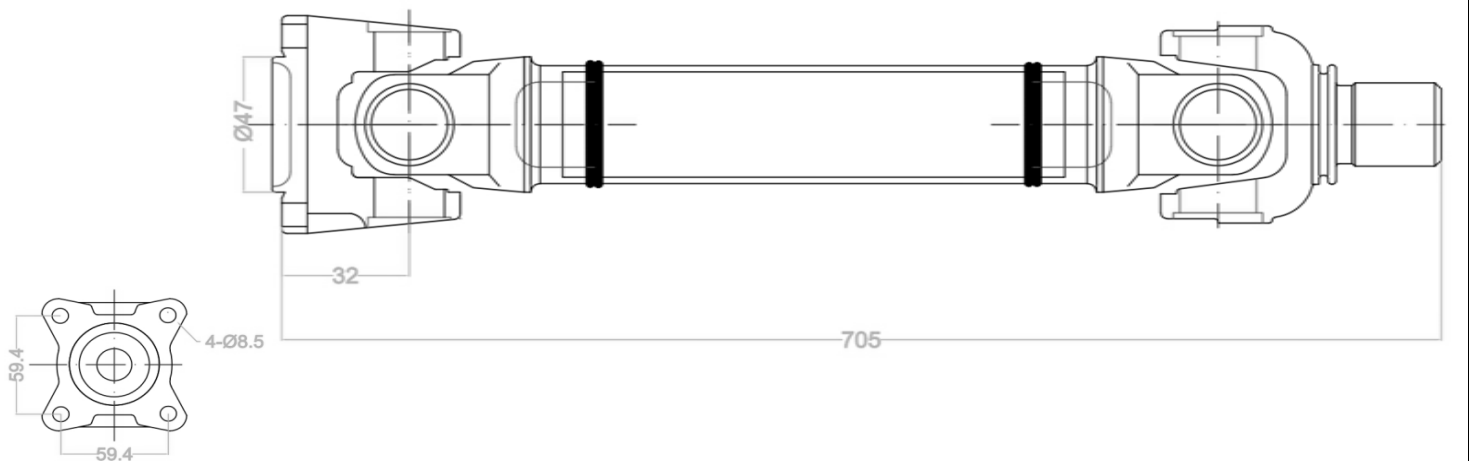

AC-0148

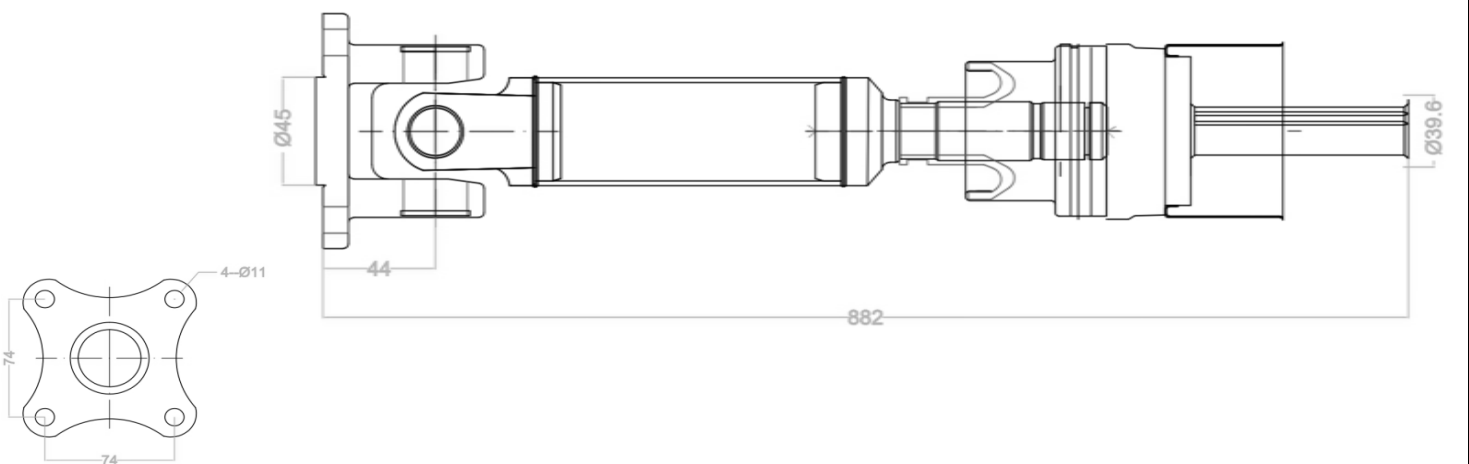

N.B.: I CODICI O.E. ED IL LORO TESTO SONO RIPORTATI SOLO A TITOLO INDICATIVO
 THE O.E. CODES AND THEIR TEXT ARE REPORTED ONLY FOR INDICATIVE PURPOSE

DISEGNI TECNICI - TECHNICAL DRAWINGS

AC-0149

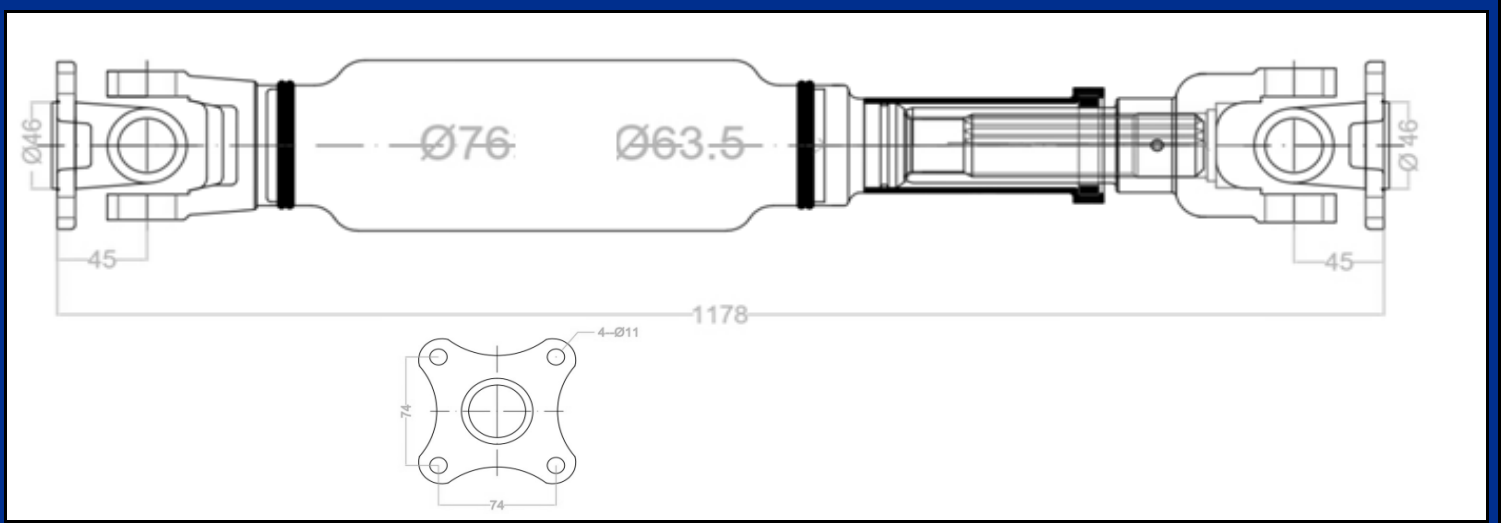

AC-0150

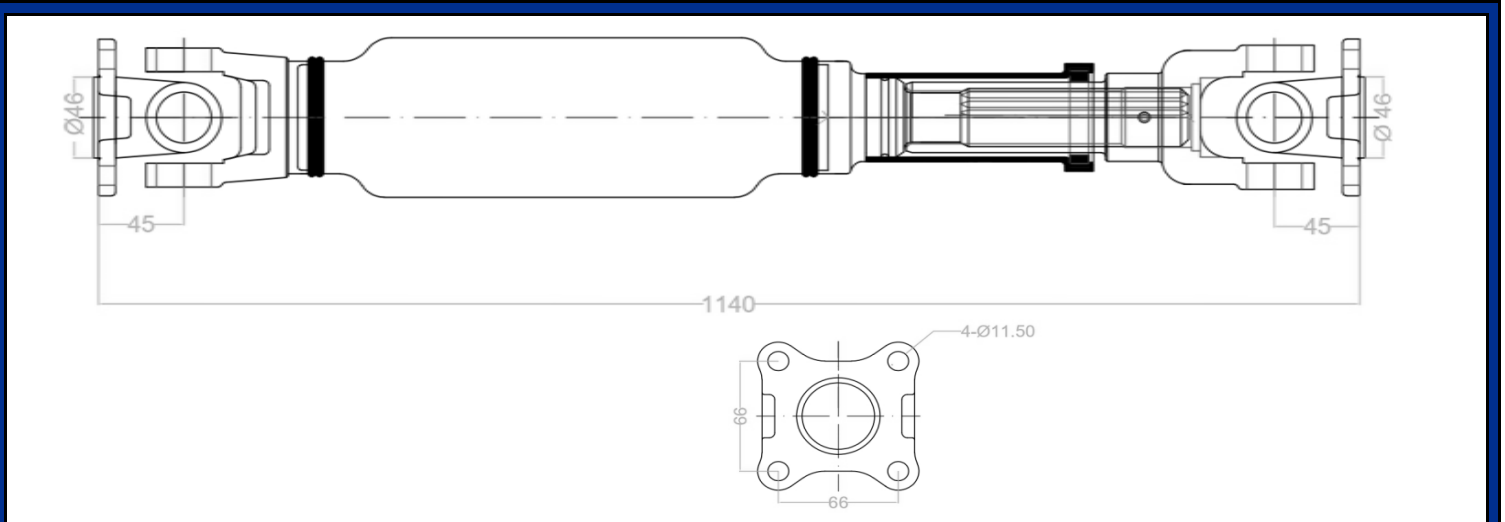

AC-0151

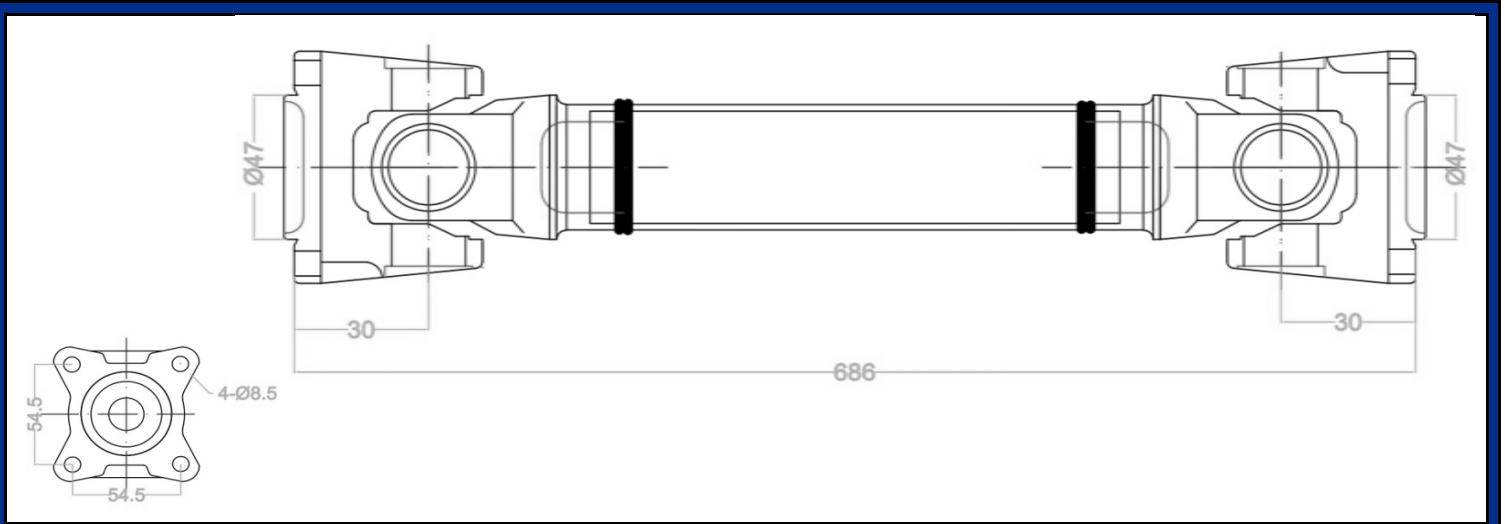

N.B.: I CODICI O.E. ED IL LORO TESTO SONO RIPORTATI SOLO A TITOLO INDICATIVO
 THE O.E. CODES AND THEIR TEXT ARE REPORTED ONLY FOR INDICATIVE PURPOSE

DISEGNI TECNICI - TECHNICAL DRAWINGS

AC-0152

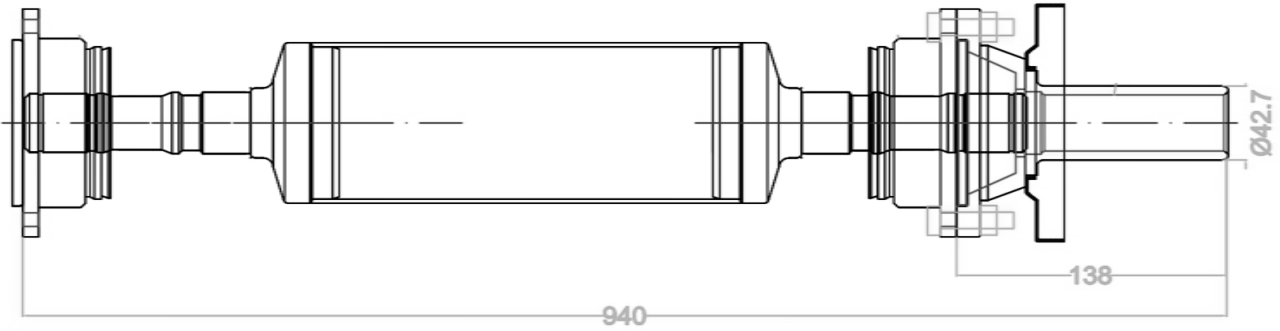

AC-0153



AC-0154



N.B.: I CODICI O.E. ED IL LORO TESTO SONO RIPORTATI SOLO A TITOLO INDICATIVO
THE O.E. CODES AND THEIR TEXT ARE REPORTED ONLY FOR INDICATIVE PURPOSE

DISEGNI TECNICI - TECHNICAL DRAWINGS

AC-0155

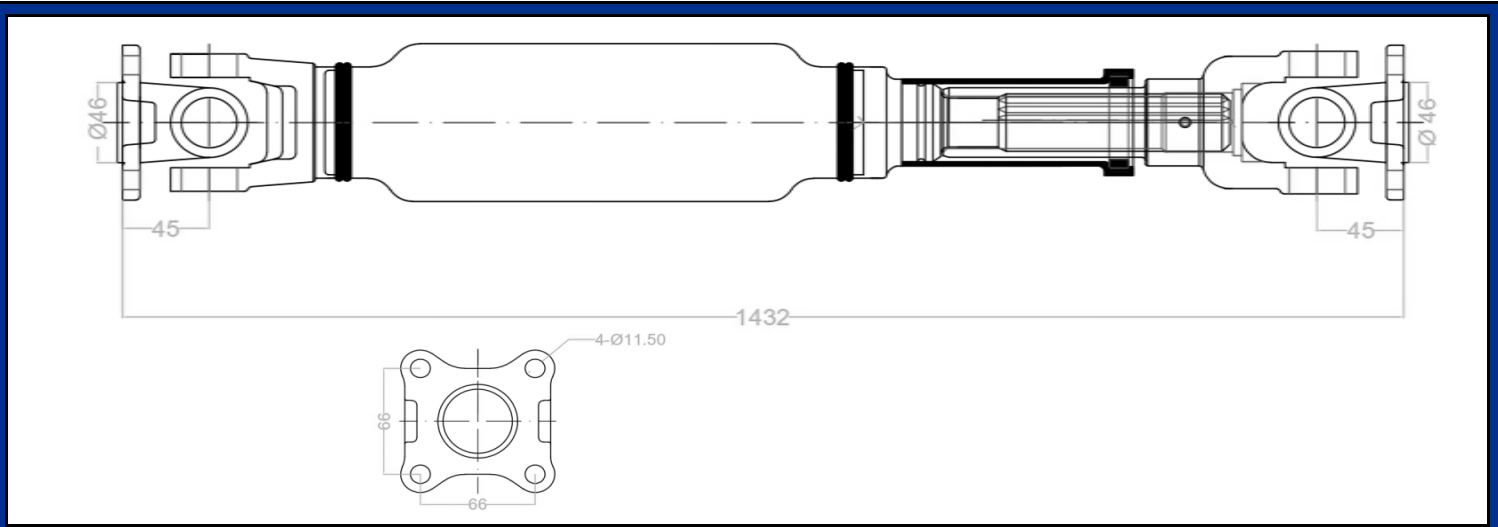

AC-0156

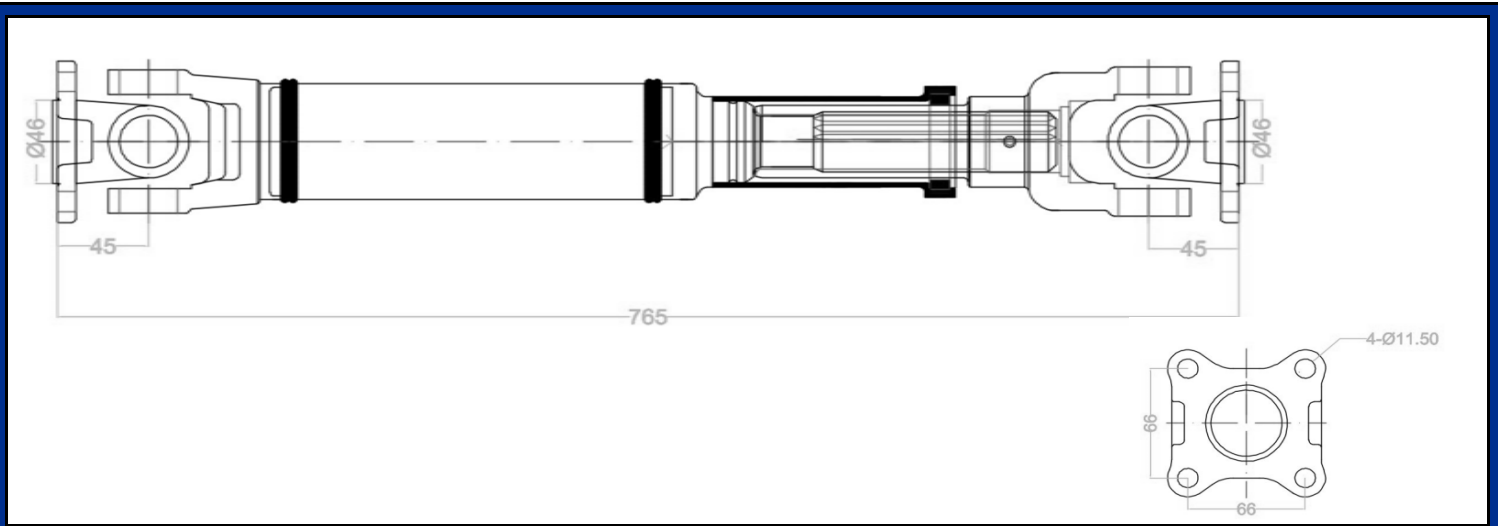

AC-0157

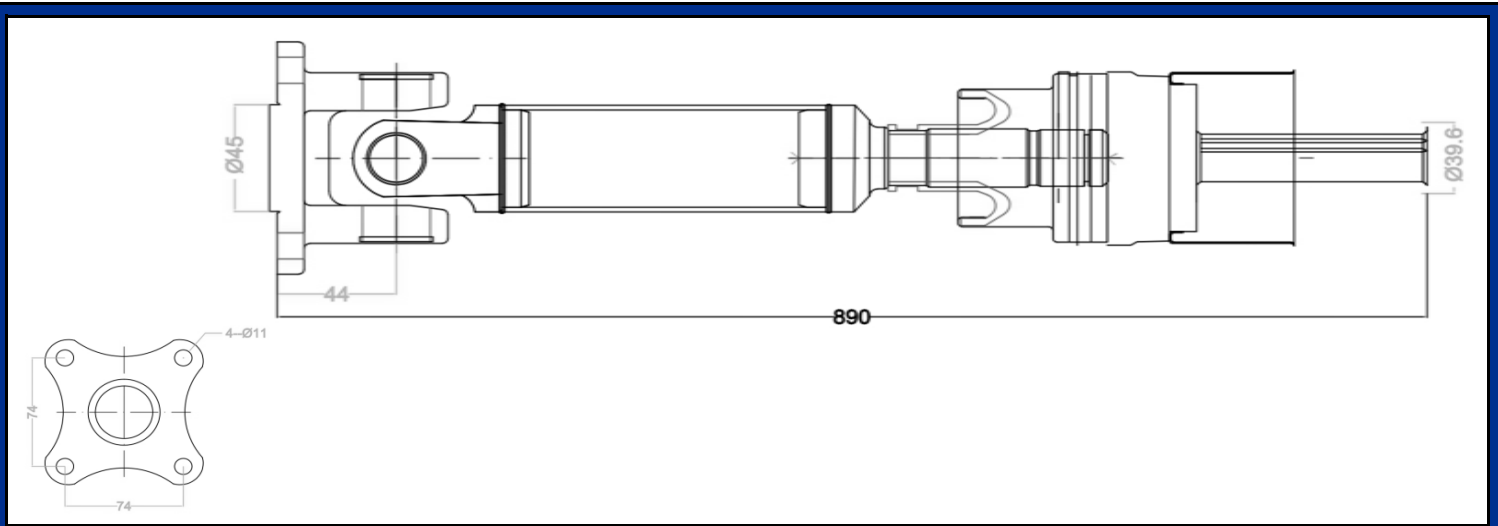

N.B.: I CODICI O.E. ED IL LORO TESTO SONO RIPORTATI SOLO A TITOLO INDICATIVO
 THE O.E. CODES AND THEIR TEXT ARE REPORTED ONLY FOR INDICATIVE PURPOSE

DISEGNI TECNICI - TECHNICAL DRAWINGS

AC-0158

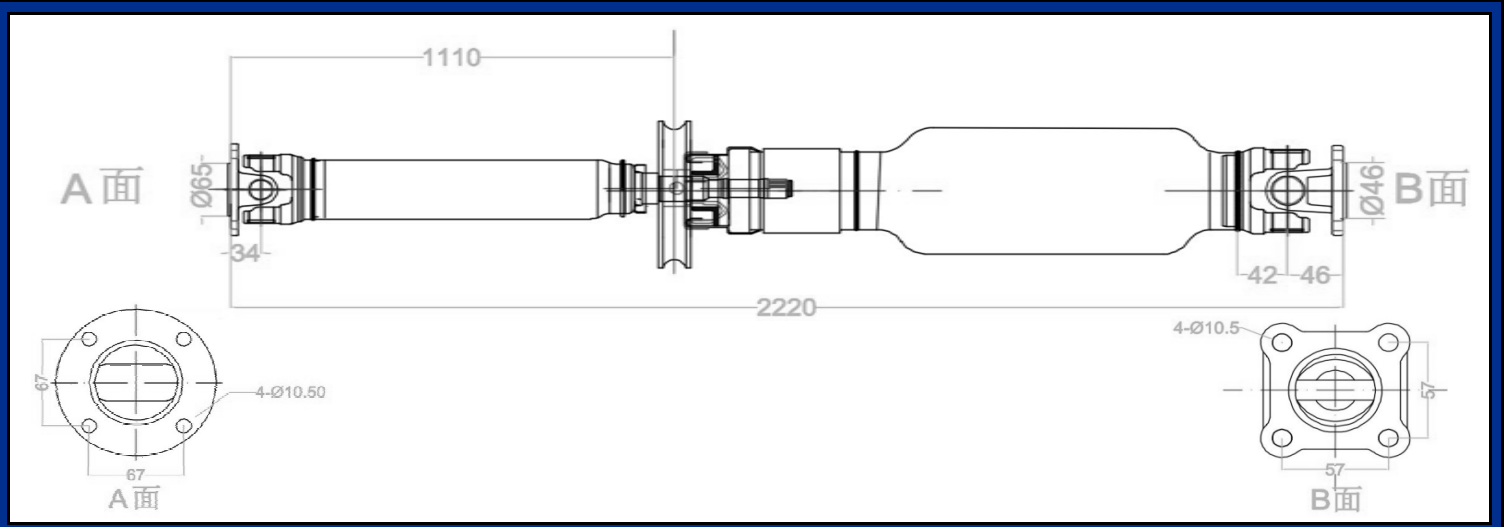

AC-0159

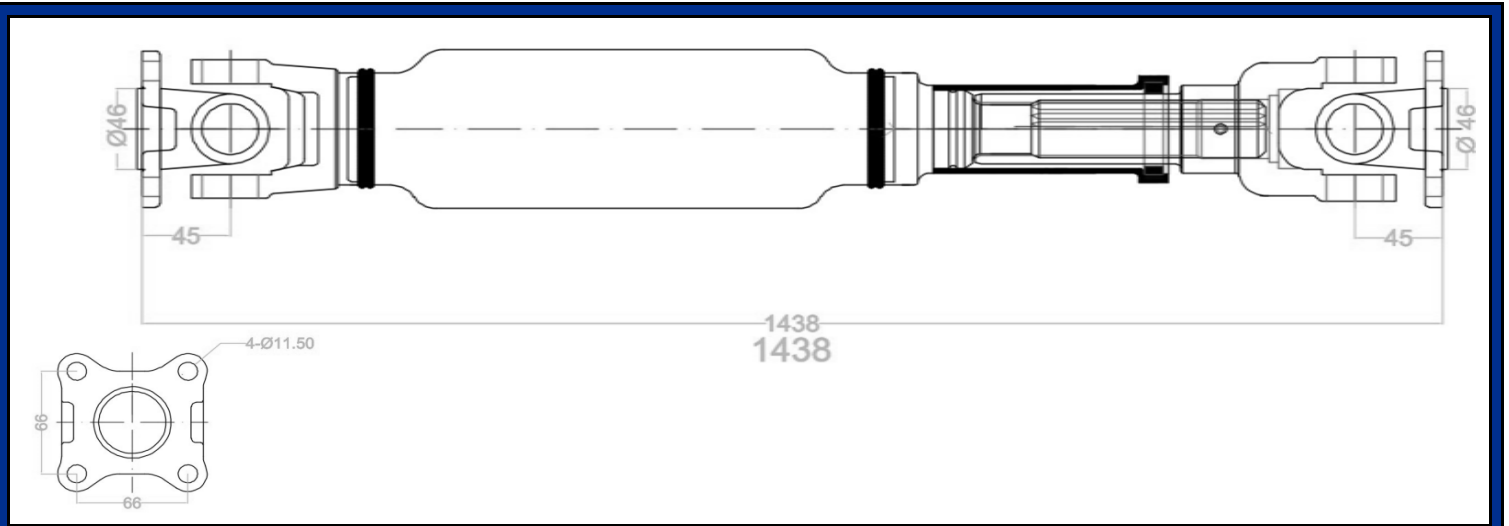

AC-0160

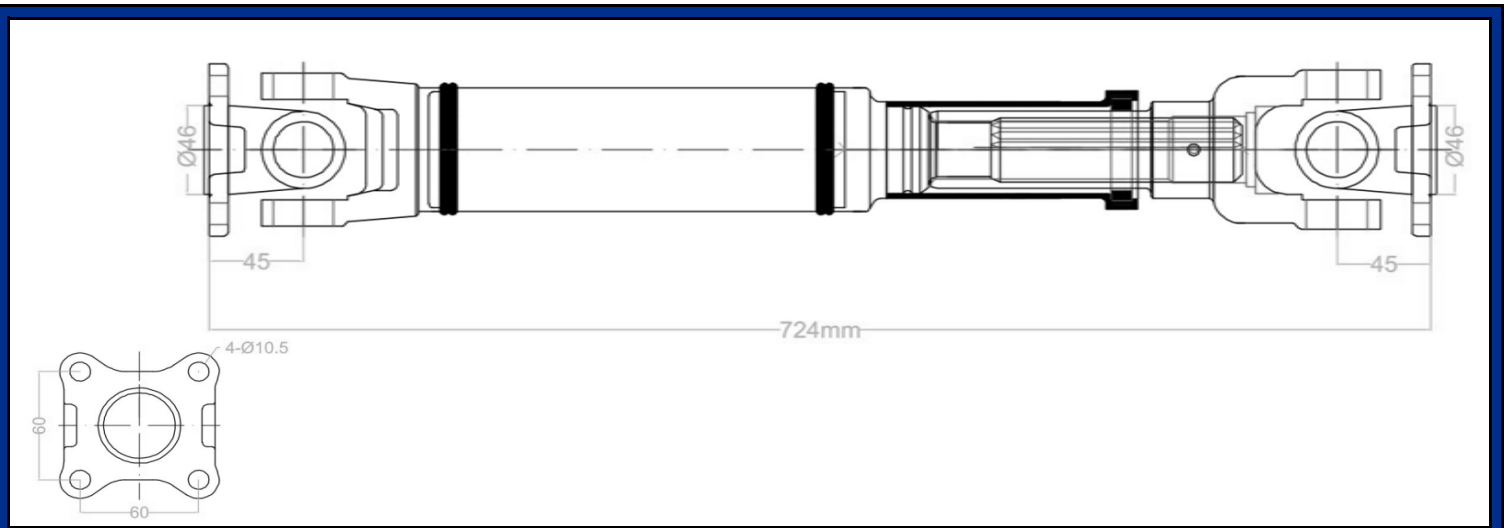

N.B.: I CODICI O.E. ED IL LORO TESTO SONO RIPORTATI SOLO A TITOLO INDICATIVO
 THE O.E. CODES AND THEIR TEXT ARE REPORTED ONLY FOR INDICATIVE PURPOSE

DISEGNI TECNICI - TECHNICAL DRAWINGS

AC-0161

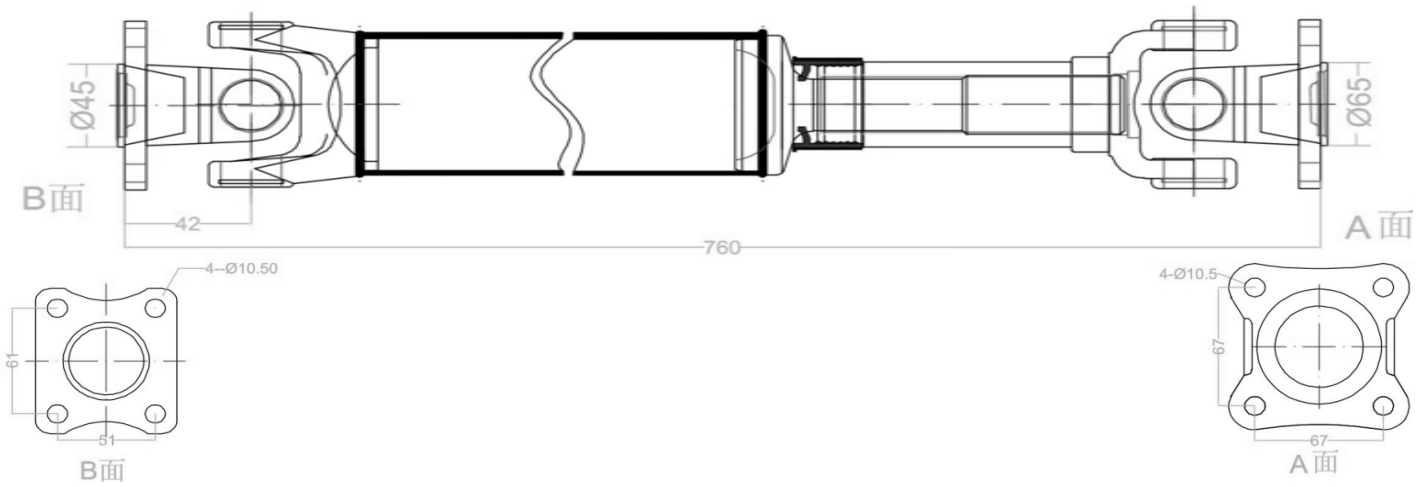

COMPARATIVA
CROSS REFERENCE



MARCA (BRAND)	O.E. (OR. NUMB.)	CODICE (CODE)
BMW	26103402134	AC-0077
BMW	26103402136	AC-0093
BMW	26107524364	AC-0092
BMW	26107527355	AC-0138
BMW	26107549298	AC-0092
BMW	26107562814	AC-0044
BMW	26107591610	AC-0044
BMW	26107614658	AC-0044
BMW	26107631361	AC-0044
BMW	26108693394	AC-0044
BMW	26111229557	AC-0090
BMW	26117523925	AC-0090
BMW	26117550770	AC-0114
BMW	26203401609	AC-0117
BMW	26203423931	AC-0151
BMW	26207508629	AC-0118
BMW	26207526677	AC-0141
BMW	26207529294	AC-0115
BMW	26207534636	AC-0116
BMW	26207556020	AC-0147
BMW	26207589985	AC-0135
BMW	26207593164	AC-0137
BMW	26207597649	AC-0014
BMW	26208605866	AC-0014
BMW	26208611252	AC-0136
BMW	26208626955	AC-0146
BMW	26209425907	AC-0014
CHEVROLET	0446073	AC-0025
CHEVROLET	15801608	AC-0139
CHEVROLET	20781756	AC-0025
CHEVROLET	92194140	AC-0125
CHEVROLET	96624771	AC-0025
CHRYSLER	68200149AA	AC-0099
CHRYSLER	68200149AB	AC-0099
CHRYSLER	68200149AC	AC-0099
CHRYSLER	68200149AD	AC-0099
CHRYSLER	68200149AE	AC-0099
CHRYSLER	936-400	AC-0099
DAIHATSU	3714087401	AC-0072
DAIHATSU	3714087403	AC-0072
DAIHATSU	3714087404	AC-0072
DAIHATSU	37140B4020	AC-0072
DODGE	5157005AD	AC-0081
DODGE	5157005AE	AC-0081
DODGE	5157005AF	AC-0081
DODGE	52105934AA	AC-0127
DODGE	68200149AA	AC-0099
DODGE	68200149AB	AC-0099
DODGE	68200149AC	AC-0099
DODGE	68200149AD	AC-0099
DODGE	68200149AE	AC-0099
DODGE	936-400	AC-0099
FIAT	4269901	AC-0129
FIAT	55193595	AC-0001
FIAT	55197051	AC-0001

MARCA (BRAND)	O.E. (OR. NUMB.)	CODICE (CODE)
FIAT	55222107	AC-0001
FIAT	55249184	AC-0045
FIAT	55264146	AC-0001
FIAT	55267431	AC-0045
FIAT	55267432	AC-0045
FIAT	55275848	AC-0045
FIAT	55275849	AC-0045
FIAT	55283215	AC-0045
FIAT	552491840	AC-0045
FIAT	552674310	AC-0045
FIAT	552674320	AC-0045
FIAT	552758480	AC-0045
FIAT	552832150	AC-0045
FIAT	3401B041	AC-0161
FORD	1826578	AC-0067
FORD	2126752	AC-0067
FORD	7E5Z4R602A	AC-0142
FORD	7L1Z4A376A	AC-0123
FORD	7L1Z4A376B	AC-0123
FORD	7T4Z4R602A	AC-0140
FORD	BL3Z4R602H	AC-0124
FORD	CV614K357AD	AC-0067
FORD	CV614K357AF	AC-0067
HONDA	40100S10003	AC-0073
HONDA	40100S10A01	AC-0073
HONDA	40100S9AE01	AC-0070
HONDA	40100S9AJ01	AC-0070
HONDA	40100SCAA01	AC-0070
HONDA	40100SWAA01	AC-0080
HONDA	40100SWYE01	AC-0080
HONDA	40100SXSA01	AC-0080
HONDA	40100SZAA01	AC-0145
HONDA	40100T0AA01	AC-0133
HUMMER	10376298	AC-0083
HUMMER	15860584	AC-0083
HUMMER	15878295	AC-0083
HUMMER	25859867	AC-0083
HYUNDAI	491004A952	AC-0068
HYUNDAI	491004A970	AC-0085
HYUNDAI	491004H100	AC-0144
HYUNDAI	493002S000	AC-0110
HYUNDAI	493003S010	AC-0042
HYUNDAI	493003W000	AC-0042
JEEP	52099498	AC-0120
JEEP	05273310AA	AC-0121
JEEP	4787671AA	AC-0045
JEEP	52099499AG	AC-0119
JEEP	52105726AC	AC-0126
JEEP	52105728AB	AC-0095
JEEP	52105728AC	AC-0095
JEEP	52105728AD	AC-0095
JEEP	52105728AE	AC-0095
JEEP	52105758AB	AC-0094
JEEP	52105758AC	AC-0094
JEEP	52105758AD	AC-0094

N.B.: I CODICI O.E. ED IL LORO TESTO SONO RIPORTATI SOLO A TITOLO INDICATIVO
THE O.E. CODES AND THEIR TEXT ARE REPORTED ONLY FOR INDICATIVE PURPOSE

MARCA (BRAND)	O.E. (OR. NUMB.)	CODICE (CODE)
JEEP	52105758AE	AC-0094
JEEP	52105760AB	AC-0091
JEEP	52105760AC	AC-0091
JEEP	52105760AD	AC-0091
JEEP	52105760AE	AC-0091
JEEP	52105760AF	AC-0091
JEEP	52111594AA	AC-0016
JEEP	52111596AA	AC-0016
JEEP	52111596AB	AC-0016
JEEP	52111597AA	AC-0017
JEEP	68337821AA	AC-0045
JEEP	P52105758AE	AC-0094
JEEP	RL105760AF	AC-0091
KIA	493003S010	AC-0042
KIA	493003W000	AC-0042
KIA	491003E110	AC-0075
LAND ROVER	5H224365AA	AC-0011
LAND ROVER	5H224365BA	AC-0019
LAND ROVER	5H224365BB	AC-0019
LAND ROVER	5H224365CA	AC-0026
LAND ROVER	5H324365AA	AC-0026
LAND ROVER	6G9N7L190FD	AC-0046
LAND ROVER	7H223214AA	AC-0011
LAND ROVER	7H223219AA	AC-0011
LAND ROVER	9G9N7L190CA	AC-0046
LAND ROVER	9H527L190AA	AC-0046
LAND ROVER	AH527L190AA	AC-0029
LAND ROVER	BH527L190AA	AC-0046
LAND ROVER	BJ327L190AB	AC-0029
LAND ROVER	EJ327L190CD	AC-0029
LAND ROVER	EJ327L190CE	AC-0029
LAND ROVER	EJ327L190FA	AC-0029
LAND ROVER	FTC5320	AC-0015
LAND ROVER	FTC5428	AC-0009
LAND ROVER	FTC5430	AC-0010
LAND ROVER	LR001157	AC-0046
LAND ROVER	LR006959	AC-0046
LAND ROVER	LR007804	AC-0046
LAND ROVER	LR021552	AC-0029
LAND ROVER	LR021553	AC-0046
LAND ROVER	LR023283	AC-0046
LAND ROVER	LR024750	AC-0029
LAND ROVER	LR031394	AC-0029
LAND ROVER	LR037027	AC-0019
LAND ROVER	LR037027R	AC-0019
LAND ROVER	LR037028	AC-0026
LAND ROVER	LR049820	AC-0029
LAND ROVER	LR049821	AC-0029
LAND ROVER	LR062326	AC-0029
LAND ROVER	LR072600	AC-0029
LAND ROVER	LR072601	AC-0029
LAND ROVER	TVB000090	AC-0009
LAND ROVER	TVB000100	AC-0015
LAND ROVER	TVB000110	AC-0015
LAND ROVER	TVB000190	AC-0010

MARCA (BRAND)	O.E. (OR. NUMB.)	CODICE (CODE)
LAND ROVER	TVB000220	AC-0015
LAND ROVER	TVB000320	AC-0015
LAND ROVER	TVB000320K	AC-0015
LAND ROVER	TVB000450	AC-0037
LAND ROVER	TVB100370	AC-0015
LAND ROVER	TVB500160	AC-0011
LAND ROVER	TVB500270	AC-0019
LAND ROVER	TVB500360	AC-0019
LAND ROVER	TVB500360R	AC-0019
LAND ROVER	TVB500370	AC-0026
LAND ROVER	TVB500390	AC-0026
LAND ROVER	TVB500510	AC-0011
LAND ROVER	TVC100010	AC-0015
LAND ROVER	XH424235CA	AC-0037
LEXUS	371106A020	AC-0150
MERCEDES	1634100201	AC-0076
MERCEDES	1634100301	AC-0111
MERCEDES	1644100501	AC-0112
MERCEDES	1664100501	AC-0153
MERCEDES	1664102901	AC-0154
MERCEDES	1764100100	AC-0043
MERCEDES	1764100200	AC-0043
MERCEDES	2044100000	AC-0006
MERCEDES	2044101801	AC-0113
MERCEDES	2044107001	AC-0007
MERCEDES	2204107106	AC-0078
MERCEDES	2214103401	AC-0007
MERCEDES	2464100000	AC-0043
MERCEDES	6394102116	AC-0064
MERCEDES	6394103006	AC-0047
MERCEDES	6394103106	AC-0048
MERCEDES	6394103206	AC-0049
MERCEDES	6394103306	AC-0050
MERCEDES	6394103406	AC-0051
MERCEDES	6394103416	AC-0066
MERCEDES	6394103506	AC-0052
MERCEDES	6394103516	AC-0065
MERCEDES	6394103606	AC-0053
MERCEDES	6394103706	AC-0054
MERCEDES	6394103906	AC-0055
MERCEDES	6394104006	AC-0056
MERCEDES	6394104506	AC-0056
MERCEDES	6394104606	AC-0057
MERCEDES	6394104706	AC-0058
MERCEDES	6394104806	AC-0059
MERCEDES	6394104906	AC-0060
MERCEDES	6394107206	AC-0064
MERCEDES	9064100016	AC-0027
MERCEDES	9064100106	AC-0028
MERCEDES	9064101306	AC-0027
MERCEDES	9064101816	AC-0063
MERCEDES	9064102016	AC-0028
MERCEDES	9064102116	AC-0028
MERCEDES	9064103616	AC-0034
MERCEDES	9064104106	AC-0063

N.B.: I CODICI O.E. ED IL LORO TESTO SONO RIPORTATI SOLO A TITOLO INDICATIVO
THE O.E. CODES AND THEIR TEXT ARE REPORTED ONLY FOR INDICATIVE PURPOSE

MARCA (BRAND)	O.E. (OR. NUMB.)	CODICE (CODE)
MERCEDES	9064104406	AC-0028
MERCEDES	9064107516	AC-0027
MERCEDES	639410300680	AC-0047
MERCEDES	639410310680	AC-0048
MERCEDES	639410320680	AC-0049
MERCEDES	639410340680	AC-0051
MERCEDES	906410361680	AC-0034
MERCEDES	1634100201-39	AC-0076
MERCEDES	2044107001-80	AC-0007
MERCEDES	9064102116-80	AC-0028
MITSUBISHI	3401A018	AC-0152
MITSUBISHI	3401A022	AC-0100
MITSUBISHI	3401A448	AC-0036
MITSUBISHI	3401B041	AC-0161
MITSUBISHI	MN168569	AC-0036
MITSUBISHI	MR580388	AC-0143
MITSUBISHI	MR580389	AC-0148
MITSUBISHI	MR580390	AC-0157
NISSAN	370001AA0A	AC-0134
NISSAN	370003UC3A	AC-0041
NISSAN	370004BA0A	AC-0158
NISSAN	370004BA1A	AC-0074
NISSAN	370004BA2A	AC-0074
NISSAN	370007C001	AC-0106
NISSAN	370007C002	AC-0107
NISSAN	370007C003	AC-0105
NISSAN	370008H310	AC-0109
NISSAN	37000BR50A	AC-0040
NISSAN	37000BR50B	AC-0040
NISSAN	37000BR51A	AC-0041
NISSAN	37000BR52A	AC-0039
NISSAN	37000JD000	AC-0041
NISSAN	37000JD200	AC-0039
NISSAN	37000JG70A	AC-0041
NISSAN	37000JG70B	AC-0041
NISSAN	37000JM100	AC-0086
NISSAN	37000JM10A	AC-0086
NISSAN	37000JM13A	AC-0086
NISSAN	37000JM14A	AC-0086
NISSAN	37000JY00C	AC-0033
NISSAN	37100JM10A	AC-0086
NISSAN	372005X30A	AC-0005
NISSAN	37200DY235	AC-0005
NISSAN	37200EB300	AC-0005
NISSAN	37200EB30A	AC-0005
NISSAN	37300F3600	AC-0108
NISSAN	65-9480	AC-0097
PIAGGIO	264286	AC-0002
PIAGGIO	565341	AC-0002
PIAGGIO	615339	AC-0003
PIAGGIO	615341	AC-0002
PIAGGIO	3711087Z24000	AC-0003
PIAGGIO	CM038106	AC-0004
PORSCHE	95542102010	AC-0018
PORSCHE	95542102011	AC-0018

MARCA (BRAND)	O.E. (OR. NUMB.)	CODICE (CODE)
PORSCHE	95542102012	AC-0018
PORSCHE	95542102013	AC-0018
PORSCHE	95542102014	AC-0018
PORSCHE	95542102015	AC-0018
PORSCHE	95542102020	AC-0018
PORSCHE	95542102021	AC-0018
PORSCHE	95542102022	AC-0018
PORSCHE	95542102023	AC-0018
PORSCHE	95542102024	AC-0018
PORSCHE	95542102025	AC-0018
PORSCHE	95B521101A	AC-0087
PORSCHE	95B521101B	AC-0087
PORSCHE	95B521101D	AC-0087
PORSCHE	95B521101S	AC-0087
PORSCHE	95542102000	AC-0104
PORSCHE	95542102001	AC-0104
PORSCHE	95542102003	AC-0104
RENAULT	7711135224	AC-0061
RENAULT	8200058705	AC-0061
RENAULT	8200144401	AC-0062
RENAULT	8200149811	AC-0062
RENAULT	8200945335	AC-0035
RENAULT	320003602R	AC-0035
RENAULT	320006394R	AC-0062
RENAULT	320007974R	AC-0035
RENAULT	370002820R	AC-0035
RENAULT	370005068R	AC-0033
SUZUKI	2710061M00	AC-0038
SUZUKI	2710080J11	AC-0102
SUZUKI	2710184C00	AC-0098
SUZUKI	2710184C00000	AC-0098
SUZUKI	2710282A00	AC-0079
SUZUKI	2710384A00	AC-0071
TOYOTA	3710042060	AC-0101
TOYOTA	3710042080	AC-0020
TOYOTA	3710042090	AC-0020
TOYOTA	3714060540	AC-0160
TOYOTA	3714060590	AC-0156
TOYOTA	371000K030	AC-0130
TOYOTA	371100K030	AC-0131
TOYOTA	371106A020	AC-0150
TOYOTA	371106A260	AC-0159
TOYOTA	371106A440	AC-0149
TOYOTA	371106A620	AC-0155
TOYOTA	371400K030	AC-0132
VAG	2E0521101A	AC-0028
VAG	2E0521101CB	AC-0034
VAG	2E0521293	AC-0027
VAG	2E1521293	AC-0028
VAG	4F0521101B	AC-0082
VAG	4F0521101F	AC-0082
VAG	4H4521101B	AC-0089
VAG	4H4521101D	AC-0089
VAG	4H4521101F	AC-0089
VAG	4H4521101H	AC-0089

N.B.: I CODICI O.E. ED IL LORO TESTO SONO RIPORTATI SOLO A TITOLO INDICATIVO
 THE O.E. CODES AND THEIR TEXT ARE REPORTED ONLY FOR INDICATIVE PURPOSE



Japanparts®



**PROPELLER
SHAFTS
ALBERI
TRASMISSIONE**

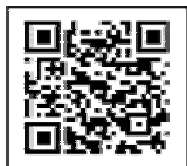
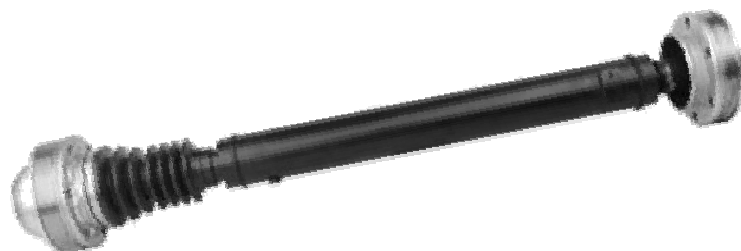

www.japanparts.it

JAPANPARTS S.R.L.

Via della Meccanica, 1/A - 37139 - Verona (IT)
tel. +39 045 8517711 - fax + 39 045 8510714
info@japanparts.it